

No.	QTY.	DESCRIPTION	MATERIAL
1	1	SPUD	CAST LOW LEAD BRASS ALLOY
2	2	GASKET	NITRILE ASTM D2000
3	2	WASHER	POLYPROPYLENE
4	2	COUPLING NUT	CAST BRASS ASTM B62 ALLOY C83600

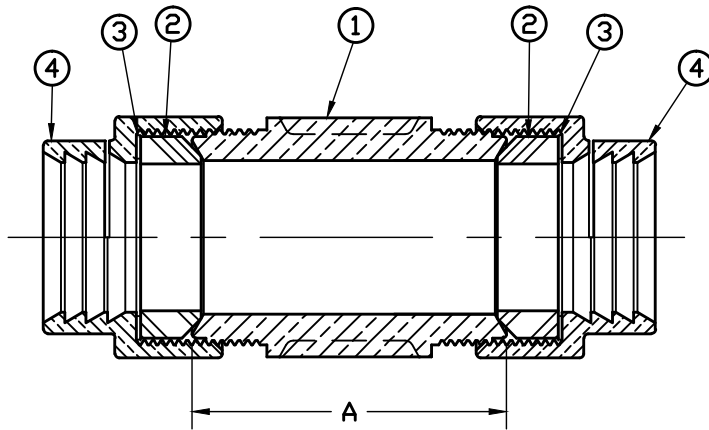

SIZE	A
3/4	2.28
1	2.64
1 x 3/4	2.15
1 1/4	3.38
1 1/2	3.35
2	2.95

NOTE: ALL WETTED PARTS ARE LOW LEAD BRASS ALLOY

FILEPATH: PROD-ENG\MUELLER\ASYSUBMITTALS\E15404N

						DRFTR	RWB	12/21/09	Mueller Co.	UNLESS OTHERWISE NOTED SURFACE PREPARATION: BREAK CORNER(S) ---- .000 SURFACE FINISH -- XX RMS TOLERANCE(S): LINEAR ----- ± .000 ANGULAR ----- ± 0°00'	THIRD ANGLE PROJECTION	
						CHKR					REF. No.	SCALE NONE
						ENGR						
						MGR						
							BY	DATE	STK No:			
									MAT'L:			
REV	ECR	DESCRIPTION	DATE	BY	CHKR	DESCR. STRAIGHT SERVICE FITTING LOW LEAD BRASS (IPS PJ x IPS PJ)					PART NUMBER E15404N	
PER EST NO: DXXXX EST FIN WT = 0.0000 lbs												

PART NUMBER
E15404N
442-MRKTNG