

No.	DESCRIPTION	MATERIAL
1	SPUD	CAST LOW LEAD BRASS ALLOY
2	CONN. NUT	CAST BRASS ASTM B62 ALLOY C83600
3	CTS GSKT SUB	SBR D2000 - GSKT 410ss - BAND

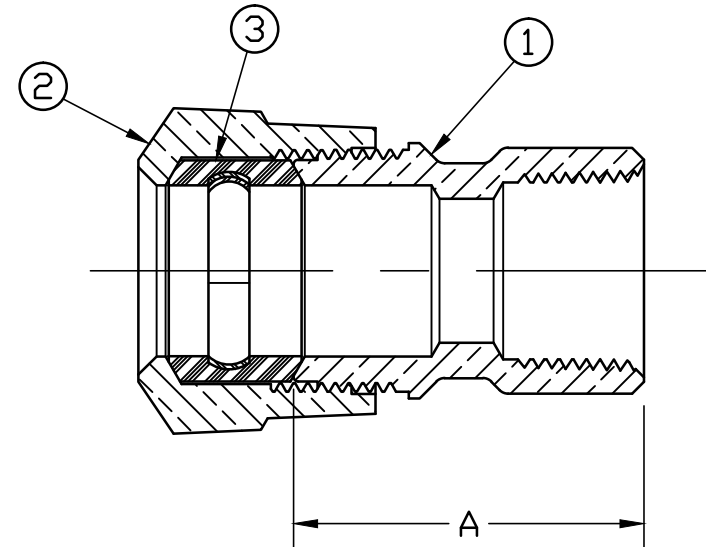

SIZE	A
1/2"	1.564
1/2" x 3/4"	1.900
5/8" x 3/4"	1.750
3/4"	1.965
3/4" x 1/2"	1.825
3/4" x 1"	1.766
1"	2.094
1" x 3/4"	1.625
1" x 1-1/4"	2.516
1-1/4"	2.469
1-1/4" x 1"	2.194
1-1/2"	2.500
1-1/2" x 1"	2.880
2"	2.562
2" x 1-1/2"	2.265

NOTE: ALL WETTED PARTS ARE LOW LEAD BRASS ALLOY

FILEPATH: PROD-ENG\MUELLER\ASYSUBMITTALS\H15451N

DRFTR	JGarvir	9/17/09	Mueller Co.		
CHKR					
ENGR					
MGR					
			UNLESS OTHERWISE NOTED	THIRD ANGLE PROJECTION	
			SURFACE PREPARATION:		
			BREAK CORNER(S) ---- .000		
			SURFACE FINISH -- 000 RMS	REF. No.	
			TOLERANCE(S):	SCALE	
			LINEAR ----- ± .000	NONE	
			ANGULAR ----- ± 0°00'		
			STK No:		
			MAT'L:		
			DESCR.	DWG NUMBER	
			STRAIGHT LLB SERVICE FITTING	H15451N	
			(110 CTS x FIP)		
REV	ECR	DESCRIPTION	DATE	BY	CHKR
PER EST NO: DXXXX EST FIN WT = 0.0000 lbs					

DWG NUMBER
H15451N
442-MRKTG

TITLE TO AND OWNERSHIP OF THIS ENGINEERING DATA REMAINS IN Mueller Co. NO USE IS TO BE MADE OF THIS DATA EXCEPT AS SPECIFICALLY AUTHORIZED BY Mueller Co. ASSENT ON THE PART OF THE RECIPIENT TO THESE CONDITIONS IS PRESUMED