

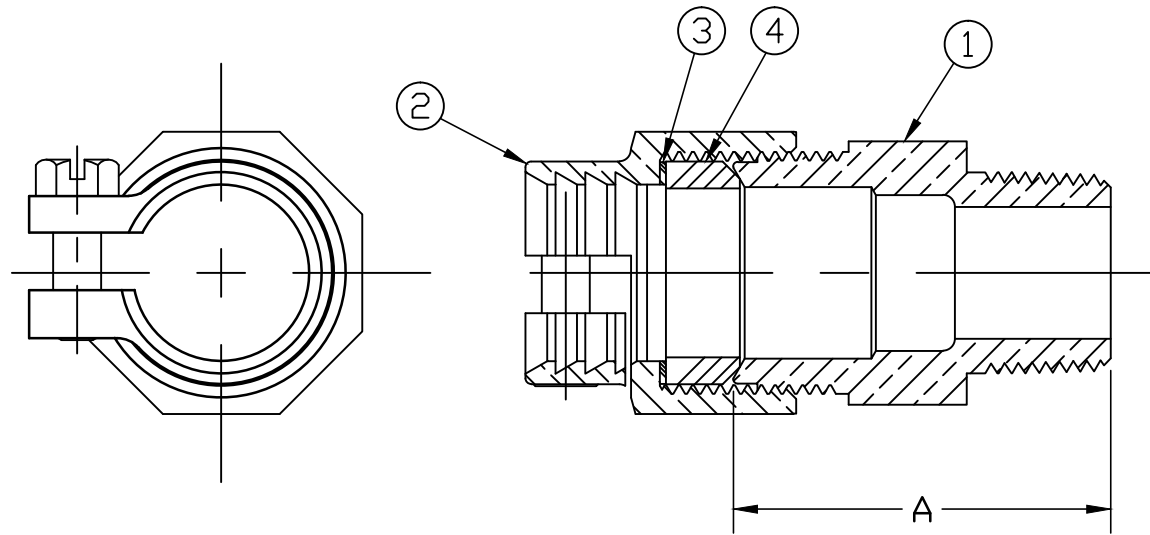

No.	DESCRIPTION	MATERIAL
1	SPUD	CAST LOW LEAD BRASS ALLOY
2	PJ CPLG NUT	CAST BRONZE ASTM B62 ALLOY C83600
3	PJ GASKET	ASTM D2000 NITRILE
4	PJ WASHER	POLYPROPYLENE



SIZE	A
3/4	1.965
3/4x1	2.125
1	2.156
1x3/4	1.976
1-1/2	2.375
1-1/2x1	2.880
2	2.625

NOTE: ALL WETTED PARTS ARE LOW LEAD BRASS ALLOY

FILEPATH: PROD-ENG\MUELLER\ASYSUBMITTALS\P15428N

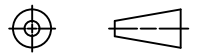
						DRFTR	RWB	12/14/12					
						CHKR							
						ENGR							
						MGR							
									UNLESS OTHERWISE NOTED	THIRD ANGLE PROJECTION			
									SURFACE PREPARATION:				
									BREAK CORNER(S) ----- .000				
									SURFACE FINISH -- 000 RMS	REF. No.	SCALE		
									TOLERANCE(S):		NONE		
									LINEAR ----- ± .000				
									ANGULAR ----- ± 0°00'				
								STK No:					
								MAT'L:					
								DESCR.	STRAIGHT LLB SERVICE FITTING (CTS PJ x MIP)	DWG NUMBER P15428N			
								REV	ECR	DESCRIPTION	DATE	BY	CHKR
								PER EST NO: DXXXX EST FIN WT = 0.0000 lbs					

DWG NUMBER
P15428N
442-MRKTG

TITLE TO AND OWNERSHIP OF THIS ENGINEERING
DATA REMAINS IN Mueller Co. NO USE IS TO BE
MADE OF THIS DATA EXCEPT AS SPECIFICALLY
AUTHORIZED BY Mueller Co. ASSENT ON THE PART
OF THE RECIPIENT TO THESE CONDITIONS IS PRESUMED