

Hydro Separator

series 548



01076/08 NA

Replaces 01076/06 NA



BSI EN ISO 9001:2000
Cert. n° FM 21654



UNI EN ISO 9001:2000
Cert. n° 0003



Function

This device consists of several different functional components, each of which meets specific requirements, typical of the circuits used in heating and air-conditioning systems.

- **Hydronic separator**
To keep connected hydronic circuits totally independent from each other.
- **Dirt remover**
To permit the separation and collection of any impurities present in the circuits. Provided with a valved connection with discharge piping.
- **Automatic air vent valve**
For automatic venting of any air contained in the circuits. Provided with a valved connection for maintenance purposes.

Product range

Series 548 Sweat hydronic separator with insulation _____ sizes 1" and 1 1/4" sweat union
 Series 548 NPT F hydronic separator with insulation _____ sizes 1", 1 1/4", 1 1/2" and 2" NPT F union
 Series 548 Flanged hydronic separator with insulation _____ sizes 2", 2 1/2", 3" and 4" ANSI Flange
 Series NA548 Flanged hydronic separator without insulation _____ sizes 5", 6", 8", 10" and 12" ASME ANSI Flange
 *NA prefix indicates ASME tagged and registered with the National Board of Boiler and Pressure Vessel Inspectors

Technical specification

Threaded and sweat union connections

Materials: - Body: epoxy resin painted steel
 - Drain and shut-off valve: brass
 - Air vent body: brass
 Suitable fluids: water, glycol solution
 Max percentage of glycol: 50%
 Max working pressure: 150 psi (10 bar)
 Temperature range: - with insulation: 32÷210°F (0÷100°C)
 - without insulation: 32÷250°F (0÷120°C)
 Connections: - Main: 1" & 1 1/4" sweat & NPT and 1 1/2" & 2" NPT union
 - Drain: 3/4" hose
 - thermometer pocket: 1/2"

Flanged connections

Materials: - Body: epoxy resin painted steel
 - Drain and shut-off valve: brass
 - Air vent body: brass
 Suitable fluids: water, glycol solution
 Max percentage of glycol: 50%
 Max working pressure: 150 psi (10 bar)
 Temperature range: - with insulation: 32÷220°F (0÷105°C)
 - without insulation: 32÷250°F (0÷120°C)
 Connections: - Flanged: 2" ÷ 12" ANSI 150 CLASS
 - Drain: 1 1/4" & 2" NPT F

Technical specification of insulation for union connection versions

- Material: double density closed cell expanded PEX
 - Thickness: 3/4" (20 mm)
 - Density: - internal part: 2 lb/ft (30 kg/m³)
 - external part: 3 lb/ft (50 kg/m³)
 - Thermal conductivity: 32°F (0°C): 9 BTU/in (0.038 W/m·K)
 -40°F (-40°C): 11 BTU/in (0.045 W/m·K)
 - Coefficient of resistance to the diffusion of vapor: > 1.300
 - Temperature range: 32-210°F (0 -100°C)
 - Reaction to fire (DIN 4102) : class B 2

Technical specification of insulation for flanged versions up to 4"

Internal part
 - Material: rigid closed cell expanded polyurethane foam
 - Thickness: 2 3/8" (60 mm)
 - Density: 3 lb/ft (45 kg/m³)
 - Thermal conductivity: 6 BTU/in (0.023 W/m·K)
 - Temperature range: 32-220 ° F (0 – 105°C)
 External cover
 - Material: embossed aluminium
 - Thickness: 7.0-mil (0.7 mm)
 - Reaction to fire: class 1
 Head covers
 - Heat moulded material: PS

Dimensions

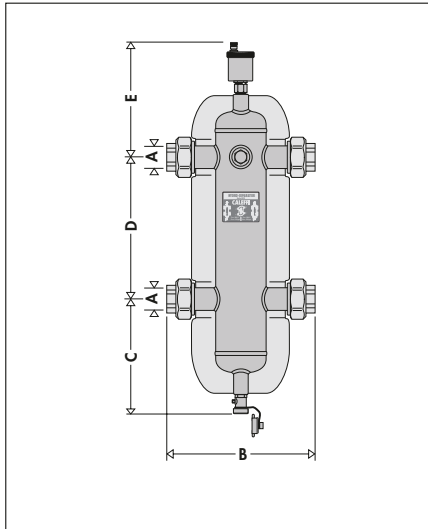

Code	A	B	C	D	E	Weight (lb)	Flow (gpm)	Volume (gal)
548 006A/96A	1"	8 3/4"	6 1/4"	8 5/8"	8"	7.5	11	0.5
548 007A/97A	1 1/4"	9 3/8"	7 3/8"	9 1/2"	8 3/8"	8.3	18	0.7
548 008A	1 1/2"	10 7/8"	7 3/4"	10 1/4"	8 3/4"	12.5	26	1.3
548 009A	2"	12"	10 1/8"	11 7/8"	9 1/2"	26.0	37	3.5

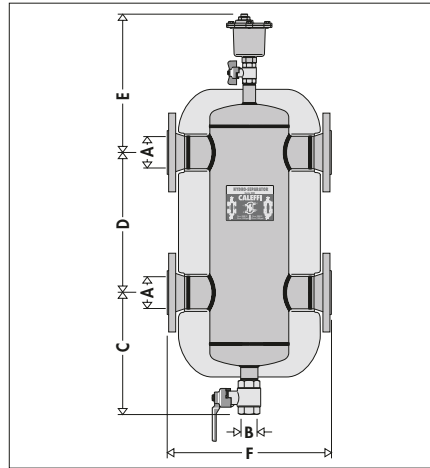

Code	A	B	C	D	E	F	Weight (lb)	Flow (gpm)	Volume (gal)
548 052A	2"	1 1/4"	13"	13"	15"	14"	73	40	4.0
548 062A	2 1/2"	1 1/4"	13"	13"	15"	14"	79	80	4.0
548 082A	3"	1 1/4"	15"	18"	17"	18"	108	124	8.0
548 102A	4"	1 1/4"	15"	18"	17"	18"	117	247	8.0
NAS48 120A*	5"	1 1/4"	15"	22"	19"	25"	220	300	22.5
NAS48 150A*	6"	1 1/4"	15"	22"	19"	25"	231	484	23.2

* without insulation

NA prefix indicates ASME tagged and registered with the National Board of Boiler and Pressure Vessel Inspectors.

Add NA prefix to 2" to 4" flanged connection for ASME approved.

For larger ASME sizes consult with factory.

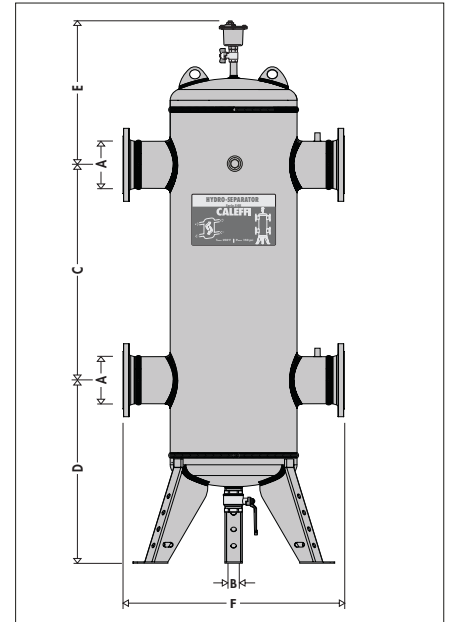

Code	A	B	C	D	E	F	Weight (lb)	Flow (gpm)	Volume (gal)
NAS48 200A	8"	2"	39 3/8"	33 7/8"	27 1/2"	35 1/2"	550	792	95
NAS48 250A	10"	2"	43 5/8"	35 7/8"	30"	41 3/4"	725	1,330	175
NAS48 300A	12"	2"	47 1/4"	37 7/8"	31 1/2"	47 3/4"	1,100	1,850	255

Operating principle

When a single system contains a primary production circuit, with its own pump, and a secondary user circuit, with one or more distributions pumps, operating conditions may arise in the system whereby the pumps interact, creating abnormal variations in circuit flow rates and pressures.

The hydronic separator creates a zone with a low pressure loss, which enables the primary and secondary circuits connected to it to be hydraulically independent of each other; **the flow in one circuit does not create a flow in the other if the pressure loss in the common section is negligible.**

In this case, the flow rate in the respective circuits depends exclusively on the flow rate characteristics of the pumps, preventing reciprocal influence caused by connection in series.

Therefore, using a device with these characteristics means that the flow in the secondary circuit only circulates when the relevant pump is on, permitting the system to meet the specific load requirements at that time.

When the secondary pump is off, there is no circulation in the secondary circuit; the whole flow rate produced by the primary pump is by-passed through the separator.

With the hydronic separator, it is thus possible to have a primary production circuit with a constant flow rate and a secondary distribution circuit with a variable flow rate; these operating conditions are typical of modern heating and cooling systems.

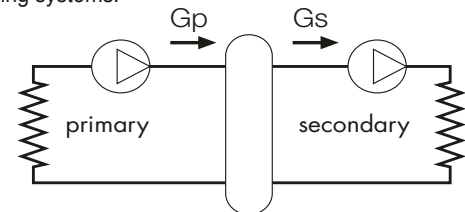

Three possible hydronic balance situations are shown below.

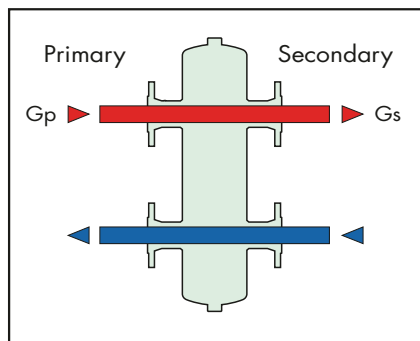

$$G_{\text{primary}} = G_{\text{secondary}}$$

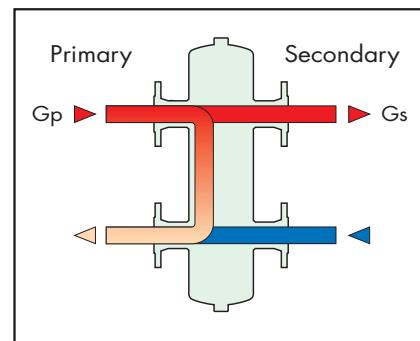

$$G_{\text{primary}} > G_{\text{secondary}}$$

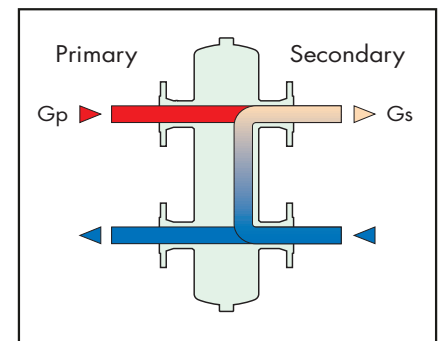

$$G_{\text{primary}} < G_{\text{secondary}}$$

Construction details

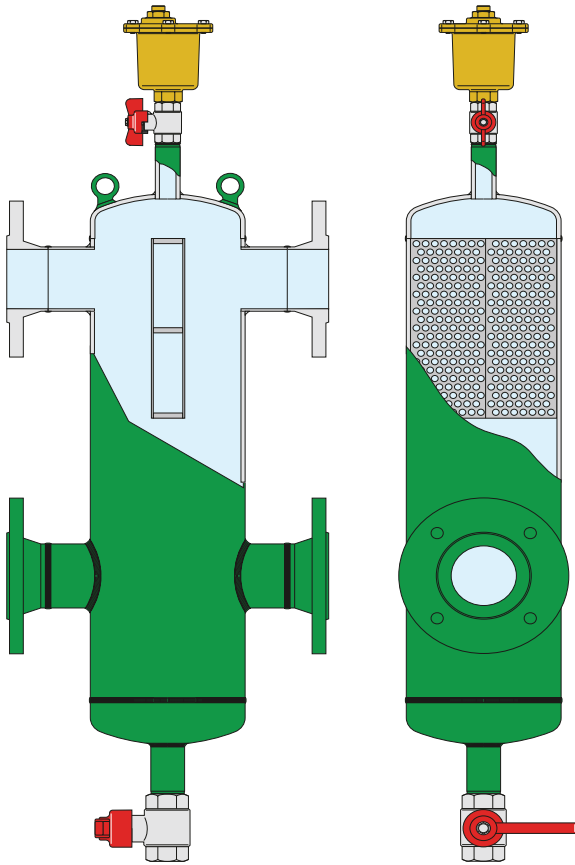

Isolating the air vent valve

In flanged separators, the air vent is isolated manually, using a shut-off ball valve. In union separators, however, the air vent body is automatically isolated by the check valve, which closes when the air vent body is removed.

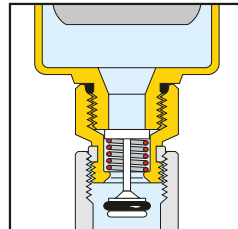

Dirt removing element

A vital function of the hydronic separator is carried out by the dirt removing element inside the device. This makes it possible to separate and collect any impurities which may be present in the system.

These impurities are removed by means of the drain valve, which can be connected to a discharge pipe, placed at the bottom of the separator.

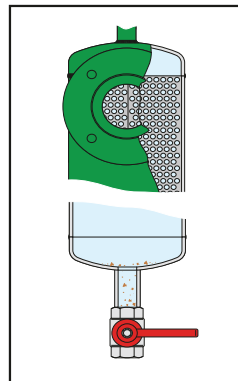

Insulation

Hydronic separators are available complete with a hot preformed insulation shell. In the flanged series, up to 4", the insulation is made of a shell in expanded polyurethane foam covered with an aluminium layer. In the threaded version the insulation is made of a pre-formed shell in double density closed cell expanded PEX.

This insulation ensures not only perfect heat insulation but also the tightness required to prevent atmospheric water vapors from entering the unit. For these reasons, this type of insulation can also be used in cooling water circuits, as it prevents the formation of condensate on the surface of the separator body.

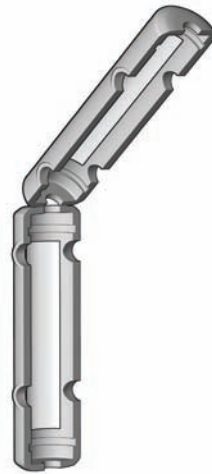

Union connections

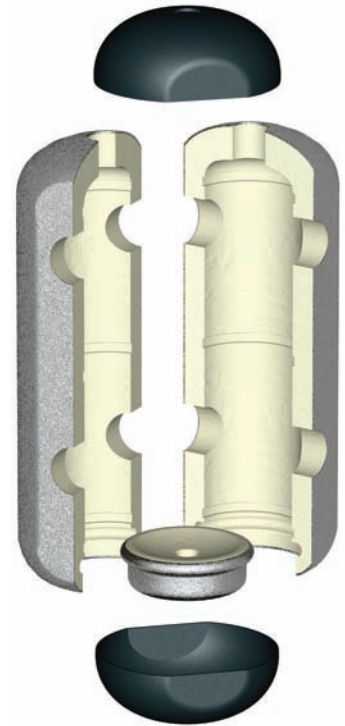

Flanged connections

Hydraulic characteristics

The hydronic separator should be sized according to the maximum flow rate value at the inlet. The selected design value must be the greatest between the primary circuit and the secondary circuit.

Union connections

Size	Flow gpm (m³/h)
1"	11 (2.5)
1 1/4"	18 (4.0)
1 1/2"	26 (6.0)
2"	37 (8.5)

Flanged connections

Size	Flow gpm (m³/h)
2"	40 (9)
2 1/2"	80 (18)
3"	124 (28)
4"	247 (56)
5"	300 (75)
6"	484 (110)
8"	792 (180)
10"	1,330 (302)
12"	1,850 (420)

Application diagram

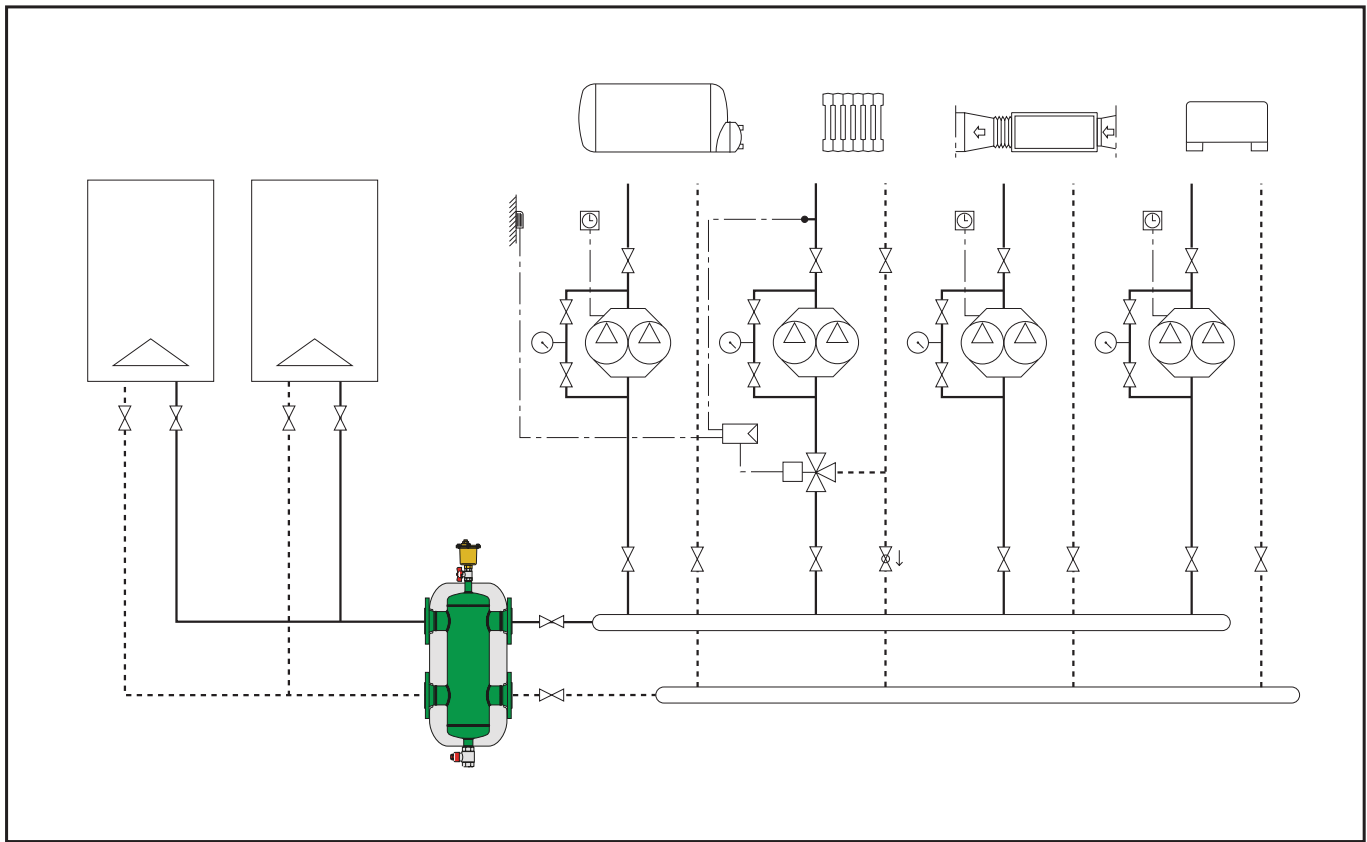

SPECIFICATION SUMMARIES

Series 548

Hydronic separator. Sweat and NPT connections with unions, 1", 1 1/4", 1 1/2", and 2" NPT. Epoxy resin painted steel body. Temperature range 32 - 210°F (0 -100°C) with insulation or 32 - 250°F (0 -120°C) without insulation. Max. working pressure 150 psi (10 bar). Supplied with: Automatic air vent valve 1/2" M connection with automatic check valve. Brass body. Drain valve. Hose connection thread. Brass body. Pre-formed insulation shell is double density closed cell expanded PEX.

Series 548

Hydronic separator. ANSI Flanged connections 2", 2 1/2", 3", 4", 5", 6", 8", 10" and 12". Epoxy resin painted steel body. Temperature range of 32 - 220°F (0 -105°C) with insulation. Max. working pressure 150 psi (10 bar). Supplied with: Automatic air vent with 3/8" F outlet connection and brass body. Brass body shut-off valve for air vent. Drain valve brass body with 1 1/2" or 2" F connection. Rigid closed cell expanded polyurethane foam shell insulation with external embossed aluminium cover. Sizes 5", 6", 8", 10", and 12" are ASME tagged and registered with the National Board of Boiler and Pressure Vessel Inspectors, without insulation and temperature range of 32 - 250°F (0 -120°C).

We reserve the right to change our products and their relevant technical data, contained in this publication, at any time and without prior notice.



Caleffi North America, Inc.
3883 W. Milwaukee Rd. / Milwaukee, WI 53208
Tel: 414.238.2360 / Fax: 414.238.2366 / www.caleffi.us
© Copyright 2008 Caleffi North America, Inc.