



model 7260B-7270B

AXION® MSR Wall Mount Eye/Face Wash

FEATURES & BENEFITS

QUALITY CONTROL

Eye/face wash and valve assembly is pre-built and fully water/pressure tested to ensure no leaks and proper function which ultimately reduces installation time and gives the end contractor an added peace of mind. Unit also ships with pre-assembled cast-aluminum wall bracket to assist in the installation process.

BOWL

The 11" (27.9 cm) round green ABS plastic receptor is resistant to damage from alkalis

STRAINERS/FILTERS

Chrome-plated brass in-line 50 x 50 mesh water strainer prevents debris from reaching the eyewash so the unit stays functioning at its best. Strainer is easily serviceable.

EYE/FACE WASH

AXION® MSR eye/face wash head uses an inverted directional laminar flow to sweep contaminants away from the vulnerable nasal cavity.



OPTIONS

- Scald Protect Bleed Valve: Model SP157A, stainless steel scald protection bleed valve. Automatic thermal actuator bleed valve opens when internal water temperature reaches 98° F (36.7° C) and closes at 95° F (35° C).
- Thermostatic Mixing Valve: Model 9201EW AXION® Emergency Tempering Valve thermostatically mixes hot and cold water to provide a safe fluid supply for a single emergency eye/face wash, with a flow rate of 10 gpm (38.8 L).
- Dust Cover: Model 9102 is a stainless steel cover that protects the eyewash heads as well as the bowl. (Picture shows cover mounted to an eyewash.)
- Emergency Alarm System : Model 9001.5, 1/2" 120 VAC emergency alarm and light system. Buzzer and flashing light are activated by a 1/2" IPS double pole, double throw flow switch.

For more information, visit www.hawsc.com or call (888) 640-4297.

SPECIFICATIONS

Model 7260B-7270B wall mounted eye/face wash shall include a green ABS plastic 11" (27.9 cm) bowl, an AXION® MSR eye/face wash head shall feature inverted directional laminar flow which achieves Zero Vertical Velocity™ supplied by an integral 3.7 gpm flow control, chrome-plated brass stay-open ball valve equipped with stainless steel ball and stem, and chrome-plated brass in-line 50 x 50 mesh water strainer. Unit shall also include cast-aluminum chromate protected wall bracket, yellow plastic pop-off dust cover for eyewash head, universal sign, 1/2" NPT inlet, and 1-1/4" NPT waste.

APPLICATIONS

Where the eyes of any person may be exposed to injurious or corrosive materials, suitable facilities for quick flushing and cleansing of the eyes must be provided within the work area for immediate emergency use. Emergency eyewash facilities shall be in unobstructed and accessible locations that require no more than 10 seconds for the injured person to reach. Model 7260B-7270B is certified by CSA to meet the ANSI Z358.1 Standard for Emergency Eyewash and Shower Equipment.



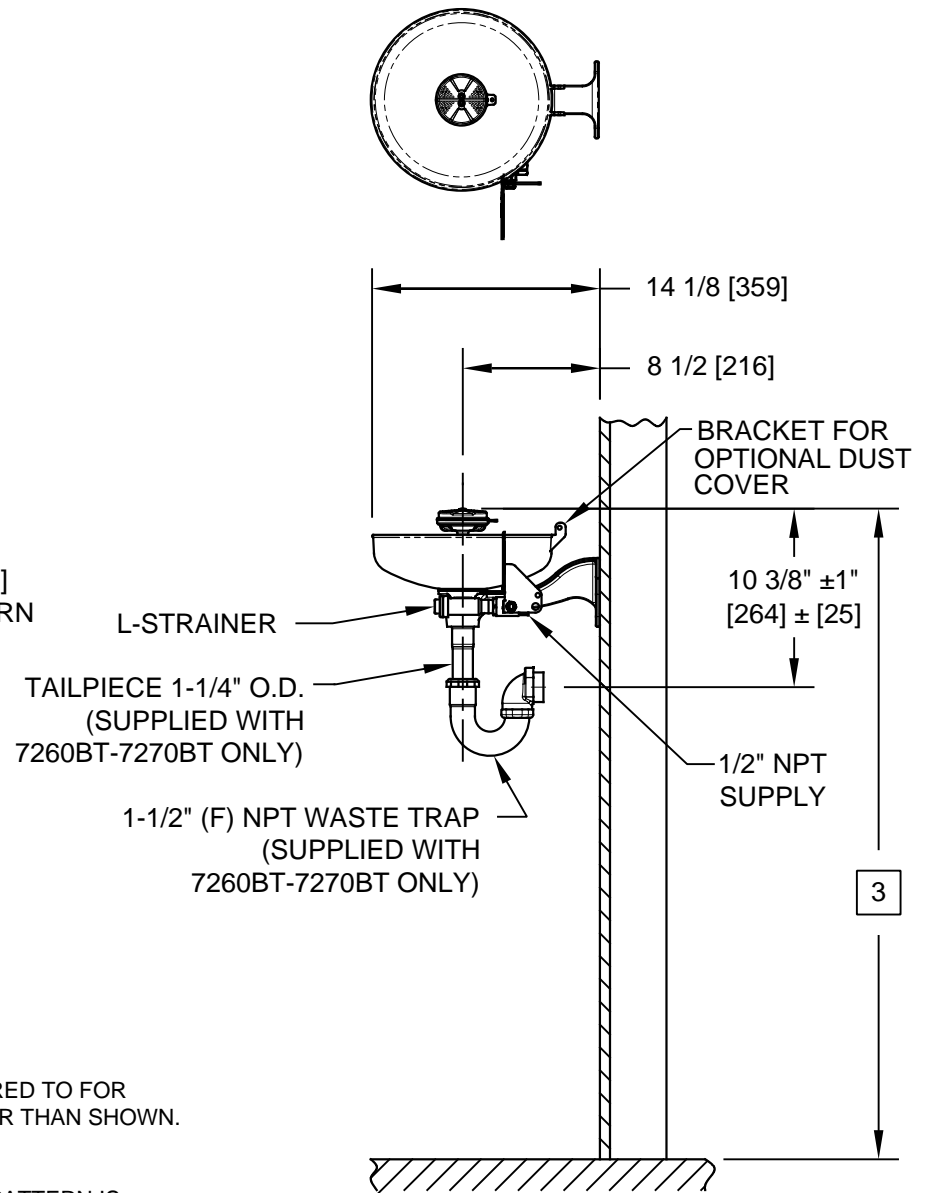
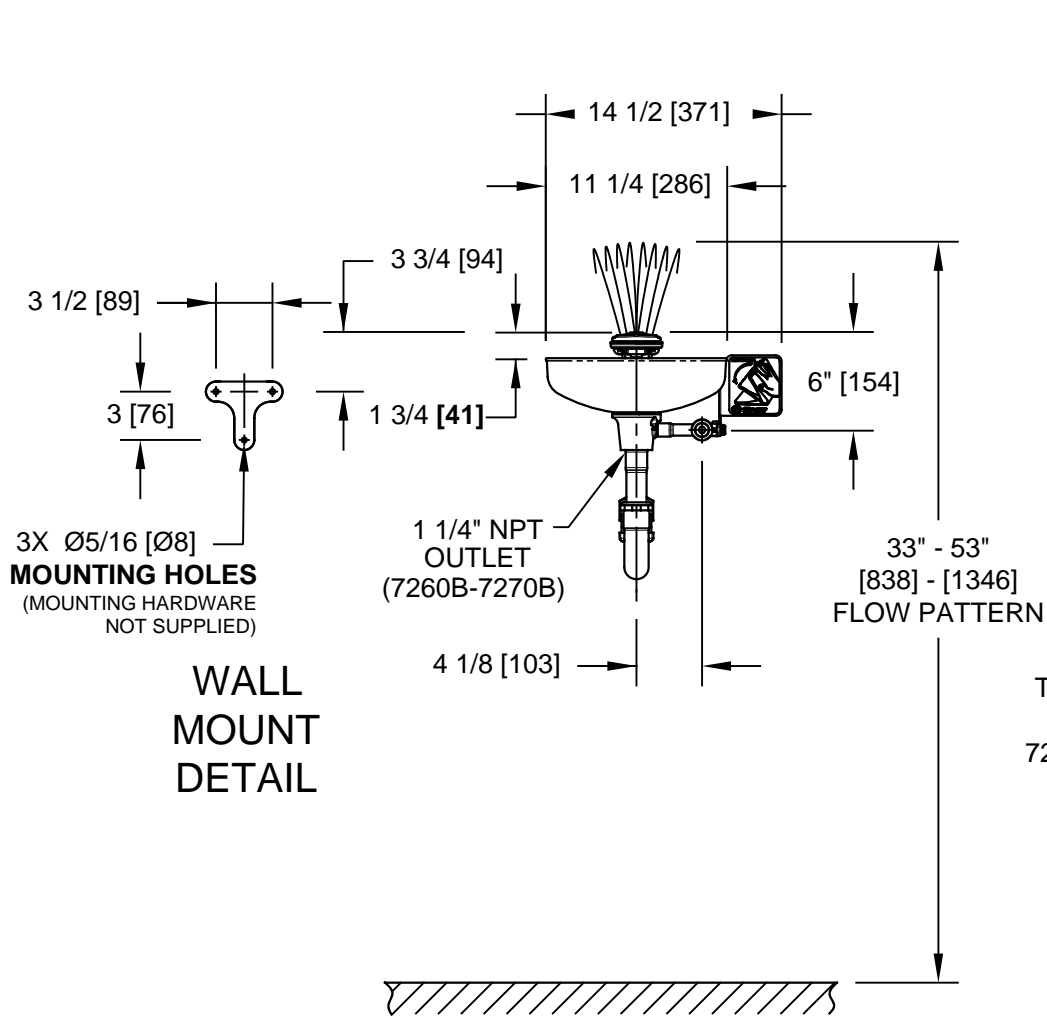

NOTES:

1. WHEN INSTALLING THIS UNIT, LOCAL, STATE, OR FEDERAL CODES SHOULD BE ADHERED TO FOR INSTALLATION DIMENSIONS (LOCATIONS), WASTE AND SUPPLY REQUIREMENTS OTHER THAN SHOWN.
2. TO COMPLY WITH ANSI Z358.1-2014 FOR EMERGENCY EYEWASH OR EYE/FACE WASH: EYEWASH OR EYE/FACE WASH SHALL BE POSITIONED SUCH THAT FLUSHING FLUID PATTERN IS NOT LESS THAN 33" (838mm) AND NO GREATER THAN 53" (1346 mm) FROM SURFACE ON WHICH USER STANDS; AND 6.0" (153mm) MINIMUM FROM WALL OR NEAREST OBSTRUCTION.

3 HEIGHT IS DETERMINED BY WATER FLOW PATTERN HEIGHT SHOWN, WHICH IN TURN, IS DEPENDENT ON IN-LINE SUPPLY PRESSURE.

4. DIMENSIONS MAY VARY BY ±1/2" (13 mm).

5. DIMENSIONS IN BRACKETS, IN DRAWING SPACE, ARE METRIC [mm].



1455 KLEPPE LANE
SPARKS, NEVADA 89431
(775) 359-4712 FAX (775) 359-7424
E-MAIL: HAWS@HAWSCO.COM
WEBSITE: WWW.HAWSCO.COM

ECN NO. 4161	REVISED PER ECN: 5175	BY: VWC	MODEL(S) 7260B-7270B/7260BT-7270BT	PART NUMBER 0002080038.D
DRAWN: SLS	DATE: 5/1/08	CHKD.: VWC		REVISION 19
APPROVED: FV	DATE: 11/23/17	SCALE: 1:1	DRAWING TYPE: INSTALLATION	SIZE: A SHEET 1 OF 1