



# model 1011HPS

Barrier-Free Dual Wall Mount Fountain

## FEATURES & BENEFITS

### CONSTRUCTION

Rugged ADA accessible 18 gauge Type 304 Stainless Steel swirl design bowl, 14 gauge Type 304 Stainless Steel bracket, and a vandal-resistant bottom plate provides a long lasting unit with added peace of mind.

### QUALITY CONTROL

Both fountains are pre-built and fully water and pressure tested to ensure proper functionality.

### BUBBLER HEAD

Polished chrome-plated brass bubbler head with integral laminar flow prevents splashing while providing a superior flow pattern. The integral 11/16" dia. basin shank and stainless anti-rotation roll pin for vandal resistance strength. Shielded, angled stream opening provides a steady source of drinking water at .45 gpm.

### DRINKING FOUNTAIN VALVE

The push-button activated valve offers the only all stainless steel valve body that is machined out of solid bar stock, is fully serviceable through the front of the push button assembly offering access to the water control cartridge and integral water supply strainer, and with front access to the water stream height adjustment for easy maintenance without having to remove the valve. Operating pressure range of 30 to 90 psi (2.1 to 6.2 bar).

### CUSTOM LOGO PANEL

Personalize your new or existing fountain or bottle filler where space permits with an optional customizable 10" high by 4.25" wide stainless steel panel. Virtually any company logo, event logo or graphic can be placed on this panel. Mounted with strong, moisture-resistant adhesive backing.

### FOUNTAIN PUSH BUTTON

All chrome plated brass push button resists vandalism by allowing it to spin without unscrewing.



## SPECIFICATIONS

Model 1011HPS Hi-Lo wall mounted barrier-free drinking fountain shall include dual 18 gauge Type 304 high-polished stainless steel finish basins with integral swirl design, 14 gauge Type 304 high-polished stainless steel wall bracket, 100% lead-free waterways, push-button operated stainless steel valves with front-accessible cartridge and flow adjustment, polished chrome-plated brass vandal-resistant bubbler heads with integral laminar anti-squirt flow, chrome-plated brass vandal-resistant waste strainers, vandal-resistant bottom plates, high-polished stainless steel finish back panel, high and low fountain mounting levels, and 1-1/4" O.D. (3.2 cm) waste pipes. (P-trap and stop require rear access).

REQUIRES MODEL 6700.4 PRICED SEPARATELY.

## OPTIONS

- Custom Logo Panel: Model 6475, Hydration By Haws™ logo panel with customization options.
- Cane Detection, Floor Mounted: Model SK6, floor mounted cane detection for the Haws Hi-Lo drinking fountains.
- Remote Drinking Fountain Water chiller: Model HCR8, 8 gph (30.3 L) remote water chiller provides instantaneous cooling to meet a continuous demand for chilled water.
- High Polished Bottle Filler: Model 1920HPS, polished stainless steel bottle filler can be a stand-alone station, or mounted above Haws 1001HPS and 1011HPS series drinking fountain models.

For more information, visit [www.hawsc.com](http://www.hawsc.com) or call (888) 640-4297.

## APPLICATIONS

Perfect for either public or private indoor/outdoor settings, Model 1011HPS is a great fit in areas where aesthetics are important to the overall appeal of the architecture. This series is precisely mounted, making it a nice addition to any surrounding. Beautiful high-polished finish helps to maintain the fountains overall appeal so it always remains looking as new as it did when it was installed. Specifically, this type of wall mounted drinking fountain may be placed in settings such as: schools and other locations in and around office buildings where the temperature remains above freezing. Model meets all current Federal Regulations for the disabled including those in the Americans with Disabilities Act. Haws manufactures drinking fountains and electric water coolers to be lead-free by all known definitions including NSF/ANSI Standard 61, Section 9, NSF/ANSI 372, California Proposition 65, and the Federal Safe Drinking Water Act. Product is compliant to California Health and Safety Code 116875 (AB 1953-2006) as evaluated by CSA International.



**NOTES:**

1. HOLD ROUGH-IN DIMENSIONS  $\pm 1/8"$  (3.2mm).
2. WHEN INSTALLING THIS UNIT, LOCAL, STATE, OR FEDERAL CODES SHOULD BE ADHERED TO FOR INSTALLATION DIMENSIONS (LOCATIONS), WASTE AND SUPPLY REQUIREMENTS OTHER THAN SHOWN.
3. INSTALLER MUST PROVIDE TRAP FOR PROPER INSTALLATION.
4. REMOVE VALVE FROM PUSH BUTTON TO INSTALL WASTE ELBOW ONTO BOWL. AFTER WASTE ELBOW IS INSTALLED, REINSTALL VALVE AND ADJUST FLOW.
5. REFER TO 5874 SERIES OPERATION AND MAINTENANCE MANUAL FOR PUSH BUTTON AND VALVE INSTALLATION/MAINTENANCE INSTRUCTIONS.

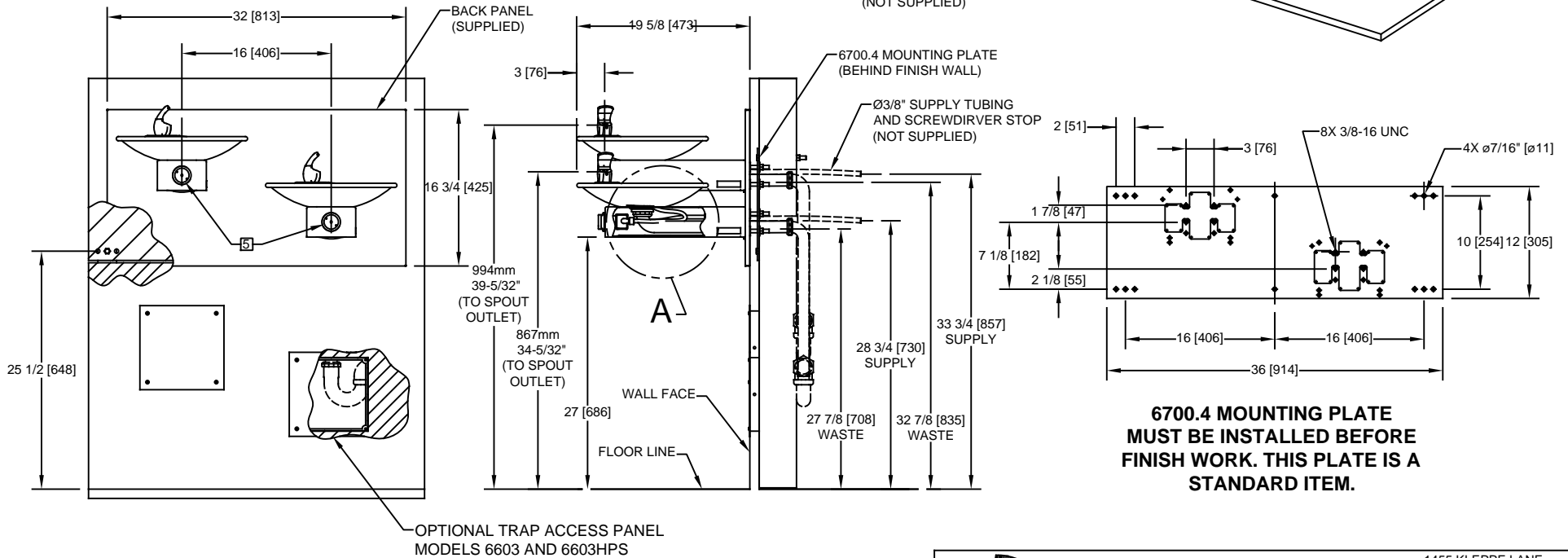
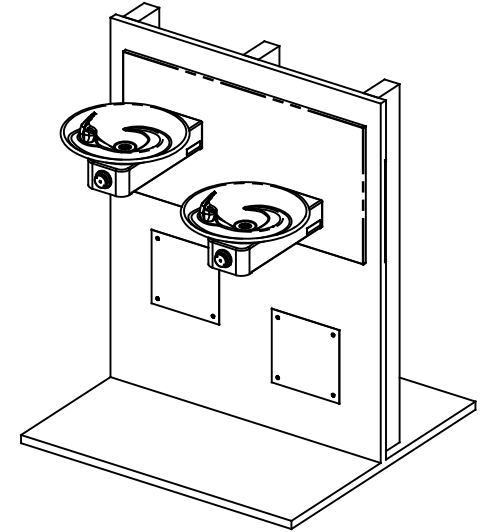
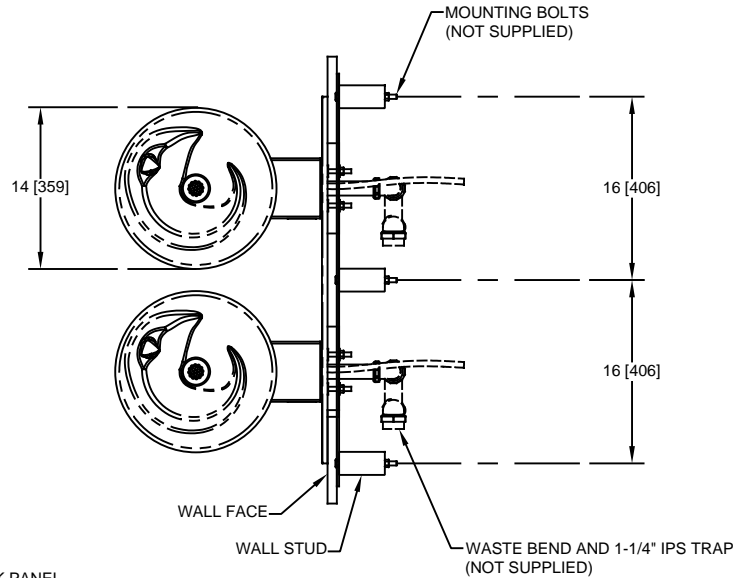
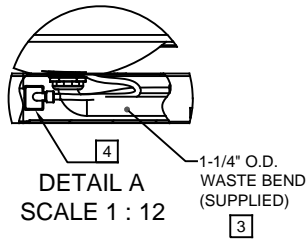

**6700.4 MOUNTING PLATE MUST BE INSTALLED BEFORE FINISH WORK. THIS PLATE IS A STANDARD ITEM.**

		1455 KLEPPE LANE SPARKS, NEVADA 89431 (775) 359-4712 FAX (775) 359-7424 E-MAIL: HAWS@HAWSCO.COM WEBSITE: WWW.HAWSCO.COM	
		ECN NO. REVISED PER BY: ECN: 5274 VWC	MODEL(S) 1011/1011HPS DRINKING FOUNTAIN
DRAWN: RM	DATE: 05/98	CHKD.: VWC	REVISION 20
APPROVED: FV	DATE: 02/23/18	SCALE: 1:1	DRAWING TYPE: INSTALLATION SIZE: A SHEET 1 OF 1