



INSTALLATION, OPERATION & MAINTENANCE INSTRUCTIONS

1455 Kleppe Lane ♦ Sparks, NV 89431-6467 ♦ (775) 359-4712 ♦ Fax (775) 359-7424
E-mail: haws@hawsco.com ♦ website: www.hawsco.com

No. 2080175(17)

Model 8336 Combination Shower Eye/Face Wash

NOTE TO INSTALLER: Please leave this information with the Maintenance Department.

LIMITED WARRANTY

HAWS warrants that this specific product is guaranteed against defective material or poor workmanship for a period of **one year from date of shipment**. HAWS liability under this warranty shall be discharged by furnishing without charge F.O.B. HAWS Factory any goods, or part thereof, which shall appear to the Company upon inspection to be of defective material or not of first class workmanship, provided that claim is made in writing to Haws within a reasonable period after receipt of the product. Where claims for defects are made, the defective part or parts shall be delivered to the Company, prepaid, for inspection. HAWS will not be liable for the cost of repairs, alterations or replacements, or for any expense connected therewith made by the owner or his agents, except upon written authority from HAWS, Sparks, Nevada. HAWS will not be liable for any damages caused by defective materials or poor workmanship, except for replacements, as provided above. Buyer agrees that Haws has made no other warranties either expressed or implied in addition to those above stated, except that of title with respect to any of the products or equipment sold hereunder and that HAWS shall not be liable for general, special, or consequential damages claimed to arise under the contract of sale.

The emergency equipment manufactured by HAWS is warranted to function if installation and maintenance instructions provided are adhered to. The units also must be used for the purpose for which they were intended. This product is intended to supplement first-aid treatment. Due to widely varying conditions, Haws cannot guarantee that the use of this emergency equipment will prevent serious injury or the aggravation of existing or prior injuries.

NO OTHER WARRANTIES EXPRESSED OR IMPLIED ARE AUTHORIZED, PROVIDED OR GIVEN BY HAWS.

SHOULD YOU EXPERIENCE DIFFICULTY WITH THE INSTALLATION OF THIS MODEL PLEASE CALL:

TECHNICAL SUPPORT: 1-800-766-5612

FOR CUSTOMER SERVICE: 1-888-640-4297

LOCATION OF UNIT: The Model 8336 Emergency Shower should be installed in close proximity to potential accident areas. It should be clearly identified, free from obstructions and easy to access.

SUPPLY LINE: The minimum recommended line size is 1-1/4" IPS with 30-90 psi (2-6 ATM) flowing pressure. Where sediment or mineral content is a problem, an inlet filter is recommended.

PLUMBING CONNECTIONS: Inlet supply is female 1-1/4" IPS. Waste outlet is 1-1/2" PVC socket weld.

TROUBLESHOOTING	
PROBLEM	REPAIR CHECKLIST
1. No flow.	1. Check the main shut-off valve.
2. Insufficient water flow.	2. Verify minimum 30 psi (2 ATM) flowing supply line pressure.
3. Insufficient water flow on eyewash, however, shower is sufficient.	3. Probable clogging of flow control due to inadequate line flushing. Unscrew eye/face wash and remove the four screws to disassemble the head. Clean flow control and reassemble head. See SP65 Installation Drawing for details.
4. Eyewash stream does not meet desired eye level.	4. Possible blocked flow control, see above solution. Possible non-leveled eyewash assembly. Eyewash nozzles should be at equal heights.
5. Insufficient water flow at the showerhead, however, eyewash is sufficient.	5. Probable clogging of flow control inside showerhead. Unscrew showerhead off of elbow and clean rubber flow control.
6. Water does not drain properly.	6. Check your drain system for debris. Check the main waste line of your building to see if it does handle the capacity required for the entire drainage system.

For more information about Haws products, see our website: www.hawesco.com

PARTS BREAKDOWN

ITEM	DESCRIPTION	PART NO.
1	S.S. BRACKET ASSY	-
2	SHOWER HEAD	SP829
3	SHOWER SIGN	SP178
4	PULL ROD	SP200
5	VALVE ASSEMBLY	SP265
6	EYEWASH BOWL	SP93
7	TEST TAG	SP170
8	DELETED	-
9	EYE/FACE WASH ASSY	SP65
10	VALVE ASSEMBLY	SP228

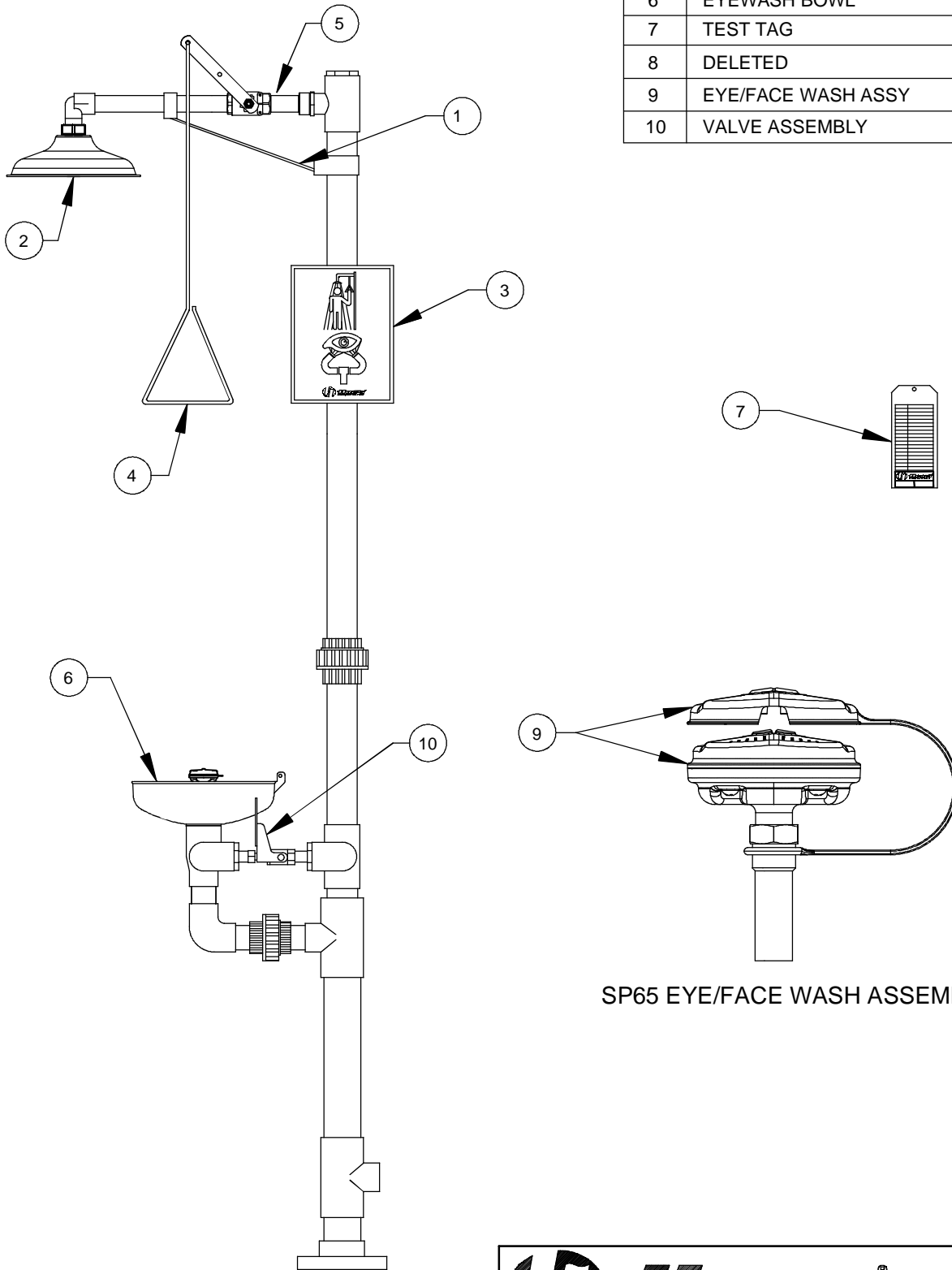

SP65 EYE/FACE WASH ASSEMBLY

WHEN ORDERING PARTS PLEASE SPECIFY MODEL NUMBER.

		Haws ®		1455 KLEPPE LANE SPARKS, NEVADA 89431 (775) 359-4712 FAX (775) 359-7424 E-MAIL: HAWS@HAWS.CO.COM WEBSITE: WWW.HAWS.CO.COM	
				ECN NO. REVISED PER BY ECN-4976 HM	MODEL(S) 8336
DRAWN CLF	DATE 3/15/93	CHKD VWC	CORROSION RESISTANT COMBO UNIT	REVISION 17	
APPROVED FV	DATE 10/21/15	SCALE: 1:16	DRAWING TYPE: PARTS BREAKDOWN	SIZE: A SHEET 1 OF 1	

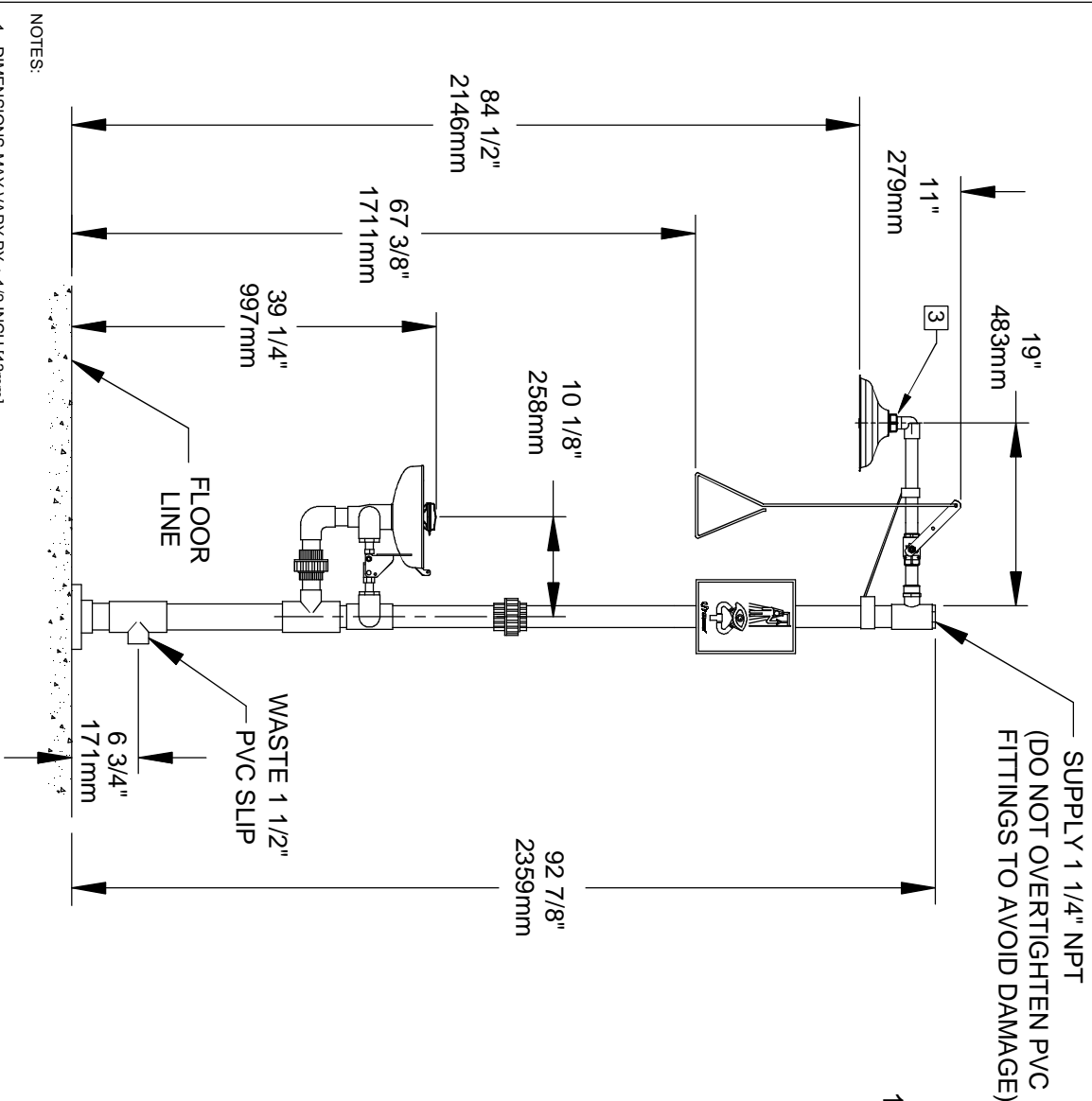

SUPPLY 1 1/4" NPT
(DO NOT OVERTIGHTEN PVC FITTINGS TO AVOID DAMAGE)

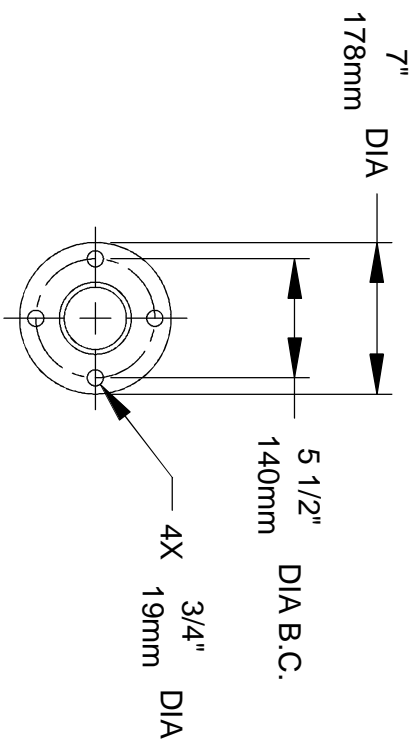

MOUNTING PATTERN

NOTES:

1. DIMENSIONS MAY VARY BY $\pm 1/2$ INCH [3mm].

2. TO COMPLY WITH ANSI Z358.1-2014 FOR EMERGENCY EYEWASH OR EYEFACE WASH AND SHOWER EQUIPMENT:

- UNIT SHALL BE INSTALLED IN ACCORDANCE WITH MANUFACTURER'S INSTRUCTIONS AND ACCEPTABLE PLUMBING PRACTICES.
- EYEWASH OR EYEFACE WASH SHALL BE POSITIONED WITH NOZZLES NOT LESS THEN 83.8 CM (33 IN.) AND NO GREATER THAN 114.3 CM (45 IN.) FROM SURFACE ON WHICH USER STANDS AND 15.3 CM (6 IN.) MINIMUM FROM WALL OR NEAREST OBSTRUCTION.
- SHOWER SHALL BE POSITIONED SO THAT SHOWER HEAD IS NOT LESS THAN 208.3 CM (82 IN.) NOR MORE THAN 243.8 CM (96 IN.) FROM SURFACE ON WHICH USER STANDS.
- SHOWER SPRAY PATTERN SHALL HAVE A MINIMUM DIAMETER OF 50.8 CM (20 IN.) AT 152.4 CM (60 IN.) ABOVE SURFACE ON WHICH USER STANDS, AND CENTER OF SPRAY PATTERN SHALL BE LOCATED AT LEAST 40.6 CM (16 IN.) FROM ANY OBSTRUCTION.

3. DO NOT USE REGULAR PIPE SEALANT. IF NECESSARY USE DOW CORNING 832 SEALANT PLACING 5 SMALL BEADS ON THE MALE THREADS, JUST ABOVE THE FIRST THREAD.



Haws

1455 KLEPPE LANE

SPARKS, NEVADA 89431

(775) 359-4712 FAX (775) 359-7424

E-MAIL: HAWS@HAWSCO.COM

WEBSITE: WWW.HAWSCO.COM

ECN NO.:	REVISED PER BY:	MODEL(S)	8336
DRAWN:	DATE:	CHK'D:	
G. Haws	01/91	VWC	
APPROVED:	DATE:	SCALE:	1/8" = 1"
EV	10/21/15	DRAWING TYPE:	INSTALLATION
CORROSION RESISTANT COMBO UNIT			PART NUMBER
			0002080175.D
			REVISION
			17
			SHEET 1 OF 1