

**SEE SHEET 2 OF 2 FOR TUBING ROUTING DETAIL**

**NOTES:**

1. HOLD ROUGH-IN DIMENSIONS  $\pm 1/4"$  (6.4mm).
2. WHEN INSTALLING THIS UNIT, LOCAL, STATE, OR FEDERAL CODES SHOULD BE ADHERED TO. FOR INSTALLATION HEIGHTS OTHER THAN SHOWN, DIMENSIONS MARKED (\*) MUST BE ADJUSTED ACCORDINGLY.
- 3 REFER TO 5874 SERIES OPERATION AND MAINTENANCE MANUAL FOR PUSH BUTTON AND VALVE INSTALLATION/MAINTENANCE INSTRUCTONS.

(NOTES CONTINUED ON SHEET 2)

		1455 KLEPPE LANE SPARKS, NEVADA 89431 (775) 359-4712 FAX (775) 359-7424 E-MAIL: HAWS@HAWS.CO.COM WEBSITE: WWW.HAWS.CO.COM	
ECN NO.	REVISED PER	BY:	MODEL(S)
	ECN: 5188	JP	1431
DRAWN:	DATE:	CHKD.:	PART NUMBER
PM	09/20/00	VWC	0002076851.D
APPROVED:	DATE:	SCALE:	REVISION
FV	07/06/17	1:10	16
DRAWING TYPE:		INSTALLATION	SHEET 1 OF 2

NOTES: (CONTINUED FROM SHEET 1)

4. CONNECT WHITE "POLYPROPYLENE" TUBING ON PRESSURE SIDE (INLET) OF VALVE.
5. CONNECT CLEAR "POLYETHYLENE" TUBING ON FREE FLOW SIDE (VALVE TO BUBBLER HEAD) ONLY.

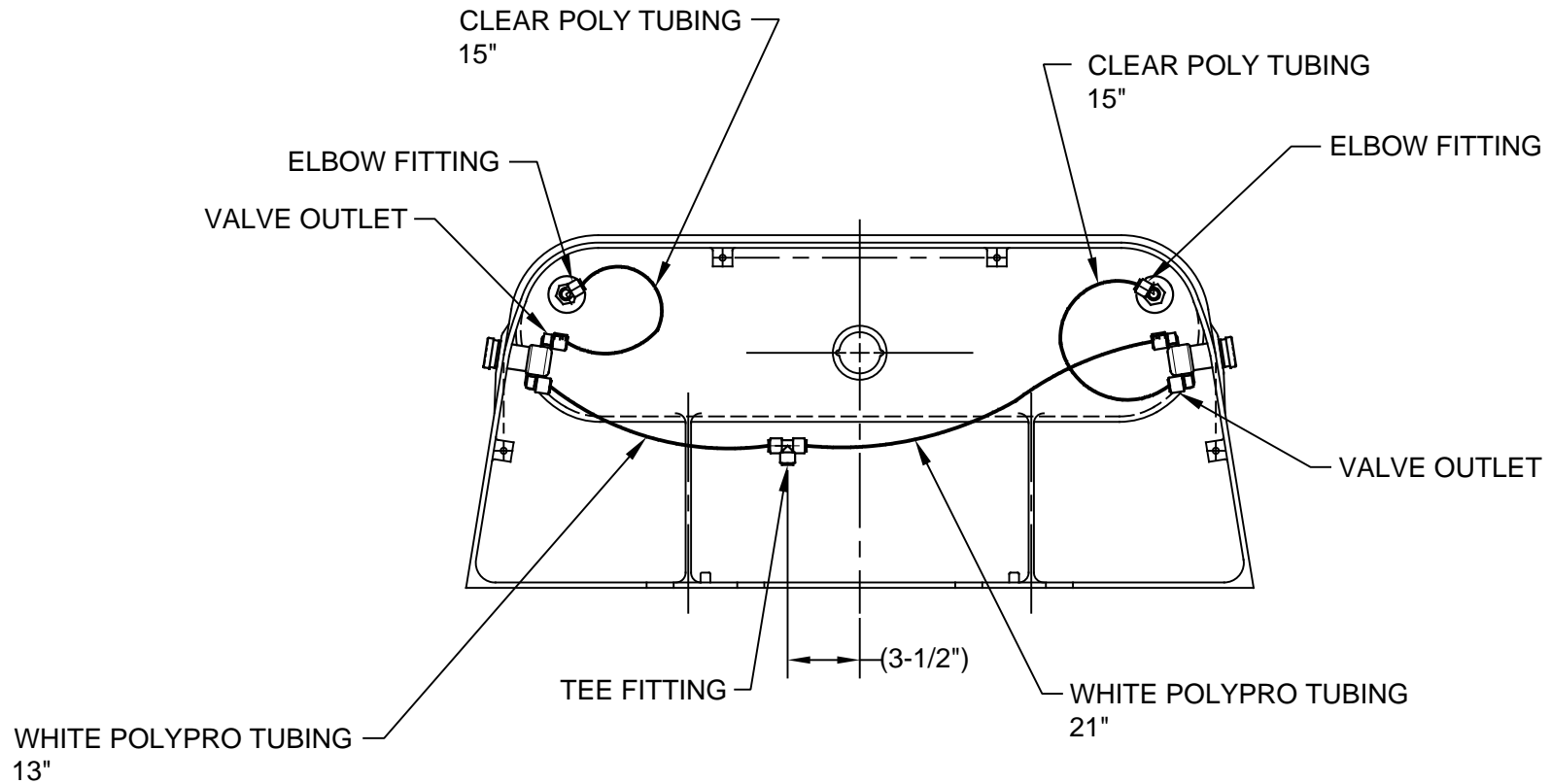

TUBING DETAIL

		1455 KLEPPE LANE SPARKS, NEVADA 89431 (775) 359-4712 FAX (775) 359-7424 E-MAIL: HAWS@HAWS.CO.COM WEBSITE: WWW.HAWS.CO.COM	
		ECN NO. REVISED PER BY: MODEL(S) ECN: 5188 JP	1431
DRAWN: PM DATE: 09/20/00 CHKD.: VWC	APPROVED: FV DATE: 07/06/17	SCALE: 1:10 DRAWING TYPE: INSTALLATION	REVISION 16 SHEET 2 OF 2