



model 7360BTWC

AXION® MSR Barrier-Free Eye/Face Wash

FEATURES & BENEFITS

QUALITY CONTROL

Eye/face wash and valve assembly is pre-built and fully water/pressure tested to ensure no leaks and proper function which ultimately reduces installation time and gives the end contractor an added peace of mind. Unit also ships with pre-assembled cast-aluminum wall bracket to assist in the installation process.

BOWL

The 11" (27.9 cm) round stainless steel receptor is supplied with a No. 2L bright finish on its exterior

VALVE

Valve is designed to make the flushing of fluid occur with the push of a stainless steel flag, and is equipped with a stainless steel ball and stem to provide added protection against corrosion and breakage.

STRAINERS/FILTERS

Chrome-plated brass in-line 50 x 50 mesh water strainer prevents debris from reaching the eyewash so the unit stays functioning at its best. Strainer is easily serviceable.

EYE/FACE WASH

AXION® MSR eye/face wash head uses an inverted directional laminar flow to sweep contaminants away from the vulnerable nasal cavity.

OPTIONS

- ❑ Scald Protect Bleed Valve: Model SP157A, stainless steel scald protection bleed valve. Automatic thermal actuator bleed valve opens when internal water temperature reaches 98° F (36.7° C) and closes at 95° F (35° C).
- ❑ Thermostatic Mixing Valve: Model 9201EW AXION® Emergency Tempering Valve thermostatically mixes hot and cold water to provide a safe fluid supply for a single emergency eye/face wash, with a flow rate of 10 gpm (38.8 L).
- ❑ Emergency Alarm System : Model 9001.5, 1/2" 120 VAC emergency alarm and light system. Buzzer and flashing light are activated by a 1/2" IPS double pole, double throw flow switch.
- ❑ Dust Cover: Model 9102 is a stainless steel cover that protects the eyewash heads as well as the bowl. (Picture shows cover mounted to an eyewash.)

For more information, visit www.hawsc.com or call (888) 640-4297.



SPECIFICATIONS

Model 7360BTWC barrier-free wall mounted eye/face wash shall include a stainless steel 11" (27.9 cm) round bowl, an AXION® MSR eye/face wash head shall feature inverted directional laminar flow which achieves Zero Vertical Velocity™ supplied by an integral 3.7 gpm flow control, wheelchair accessibility, chrome-plated brass stay-open ball valve equipped with stainless steel ball and stem, chrome-plated brass in-line 50 x 50 mesh water strainer, and chrome-plated brass trap and tailpiece. Unit shall also include 16 gauge stainless steel wall bracket, universal sign, 1/2" NPT inlet, and 1-1/4" NPT waste.

APPLICATIONS

Where the eyes and face of any person may be exposed to injurious or corrosive materials, suitable facilities for quick flushing of the eyes and face be provided within the work area for immediate emergency use. Emergency eye/face wash facilities shall be in unobstructed and accessible locations that require no more than 10 seconds for the injured person to reach. Model 7360BTWC is certified by CSA to meet the ANSI Z358.1 Standard for Emergency Eyewash and Shower Equipment.



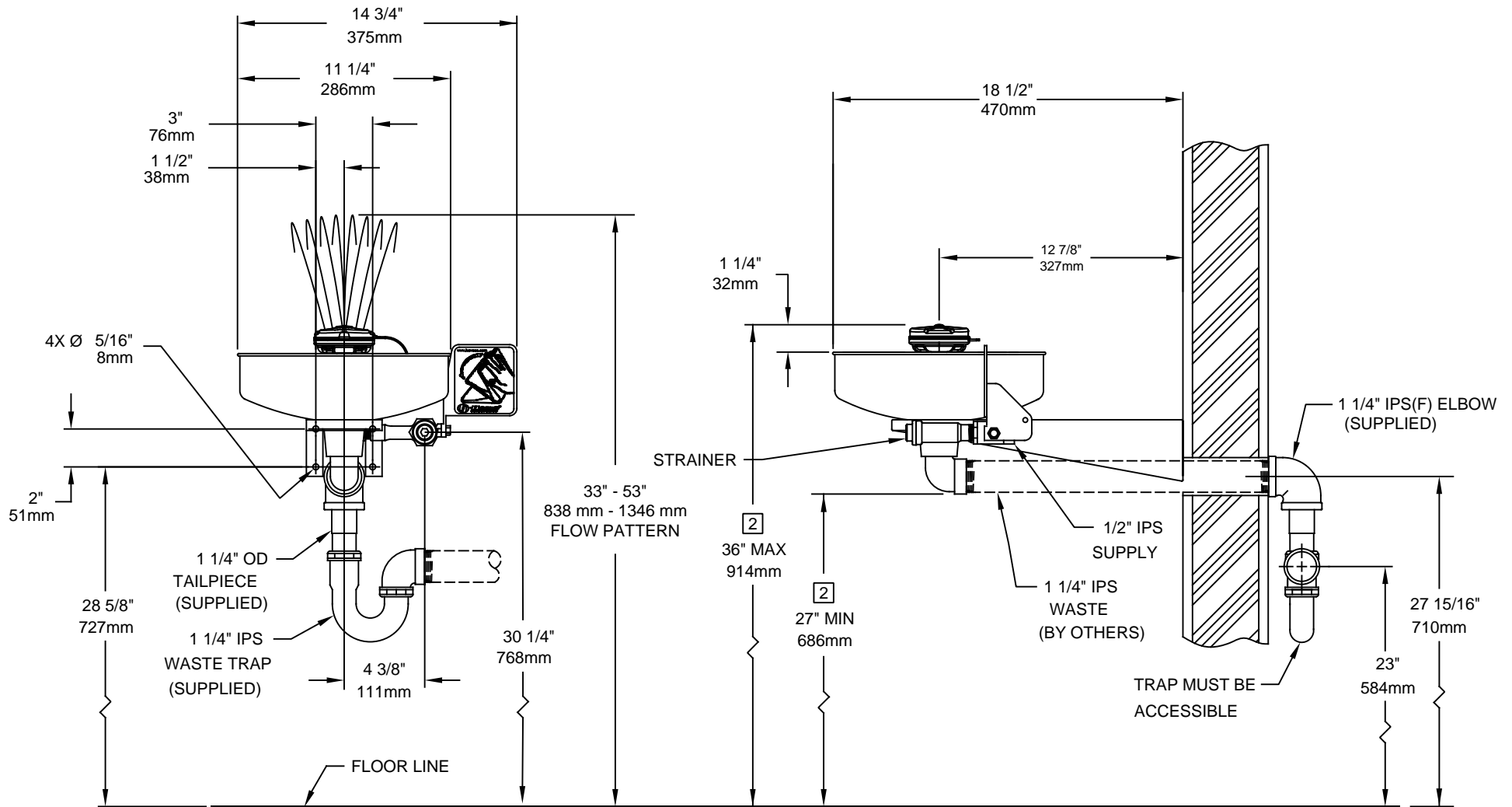

SEE SHT. 2 FOR ALTERNATE INSTALLATIONS

NOTES:

1. TO COMPLY WITH ANSI Z358.1-2014 FOR EMERGENCY EYEWASH OR EYE/FACE WASH AND SHOWER EQUIPMENT: EYEWASH OR EYE/FACE WASH SHALL BE POSITIONED SUCH THAT FLUSHING FLUID PATTERN IS NOT LESS THAN 33" (838 mm) AND NO GREATER THAN 53" (1346 mm) FROM SURFACE ON WHICH USER STANDS; AND 6.0" (153 mm) MINIMUM FROM WALL OR NEAREST OBSTRUCTION.

2. THESE DIMENSIONS MUST BE MAINTAINED TO MEET WHEELCHAIR ACCESSIBILITY REQUIREMENTS AND STILL COMPLY WITH ANSI REQUIREMENTS STATED ABOVE.

3. WHEN INSTALLING THIS UNIT, LOCAL, STATE, OR FEDERAL CODES SHOULD BE ADHERED TO FOR INSTALLATION DIMENSIONS (LOCATIONS), WASTE AND SUPPLY REQUIREMENTS OTHER THAN SHOWN.

4. DIMENSIONS MAY VARY ±1/2" [12.7mm].

		1455 KLEPPE LANE SPARKS, NEVADA 89431 (775) 359-4712 FAX (775) 359-7424 E-MAIL: HAWS@HAWS.CO.COM WEBSITE: WWW.HAWS.CO.COM	
		ECN NO. REVISED PER BY: MODEL(S) ECN: 5175 VWC	7360BTWC
DRAWN: FV DATE: 03/98 APPROVED: FV	DATE: 11/23/17	CHKD.: VWC	REVISION 9
SCALE: 1/8		DRAWING TYPE: INSTALLATION	SIZE: A SHEET 1 OF 2

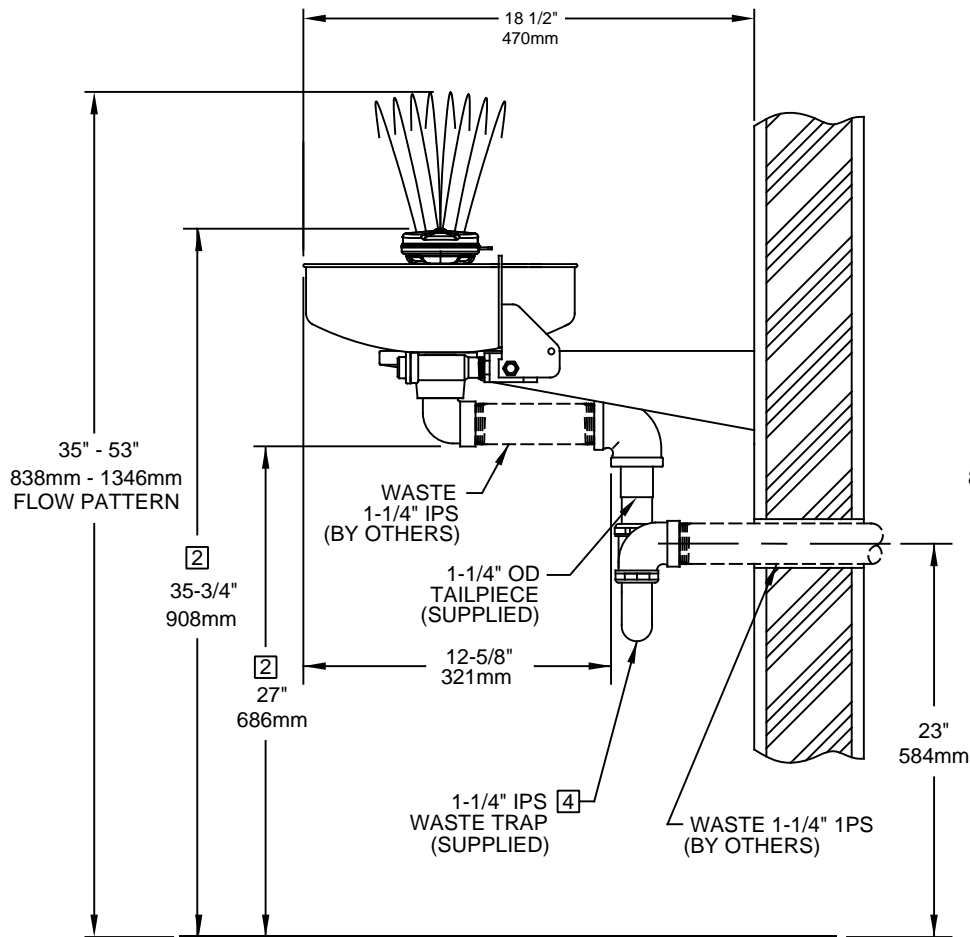

OPTION A ALTERNATE INSTALLATIONS

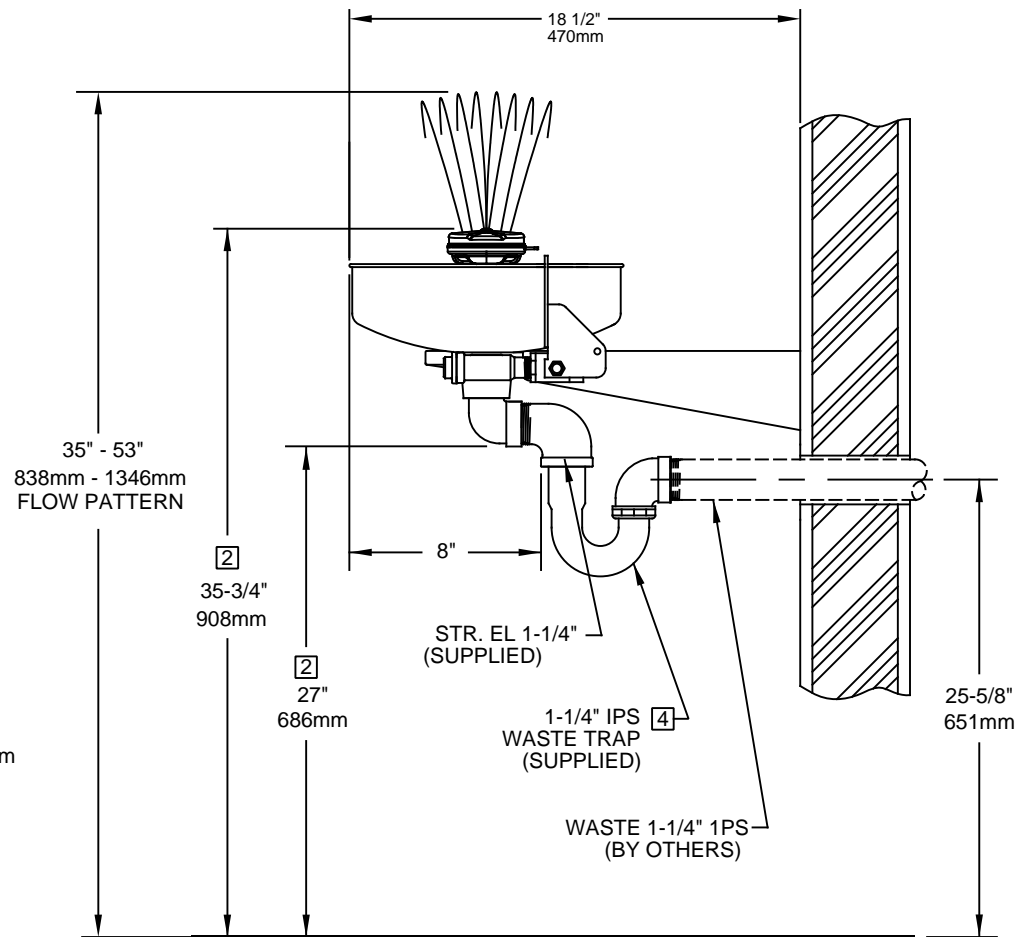

OPTION B

NOTES:

1. TO COMPLY WITH ANSI Z358.1-2014 FOR EMERGENCY EYEWASH OR EYE/FACE WASH AND SHOWER EQUIPMENT: EYEWASH OR EYE/FACE WASH SHALL BE POSITIONED SUCH THAT FLUSHING FLUID PATTERN IS NOT LESS THEN 33" (838mm) AND NO GREATER THAN 53" (1346 mm) FROM SURFACE ON WHICH USER STANDS, AND 6.0" (153 mm) MINIMUM FROM WALL OR NEAREST OBSTRUCTION.

2. THESE DIMENSIONS MUST BE MAINTAINED TO MEET WHEELCHAIR ACCESSIBILITY REQUIREMENTS AND STILL COMPLY WITH ANSI REQUIREMENTS STATED ABOVE.

3. WHEN INSTALLING THIS UNIT, LOCAL , STATE, OR FEDERAL CODES SHOULD BE ADHERED TO FOR INSTALLATION DIMENSIONS (LOCATIONS), WASTE AND SUPPLY REQUIREMENTS OTHER THAN SHOWN.

4. DIMENSIONS MAY VARY ±1/2" [12.7mm].

5. TRAP SHOULD BE WRAPPED TO PROVIDE ADDITIONAL USER PROTECTION.

		1455 KLEPPE LANE SPARKS, NEVADA 89431 (775) 359-4712 FAX (775) 359-7424 E-MAIL: HAWS@HAWSCO.COM WEBSITE: WWW.HAWSCO.COM	
		ECN NO. REVISED PER BY: MODEL(S) ECN: 5175 VWC	7360BTWC
DRAWN: FV DATE: 03/98	CHKD.: VWC	REVISION 9	
APPROVED: FV DATE: 11/23/17	SCALE: 1/8	DRAWING TYPE: INSTALLATION	SIZE: A SHEET 2 OF 2