



INSTALLATION, OPERATION & MAINTENANCE INSTRUCTIONS

1455 Kleppe Lane ♦ Sparks, NV 89431-6467 ♦ (775) 359-4712 ♦ Fax (775) 359-7424
E-mail: haws@hawsco.com ♦ website: www.hawsco.com

No. 0510000046 (3)

Model 1311 Drinking Fountain

NOTE TO INSTALLER: Please leave this information with the Maintenance Department.

LIMITED WARRANTY

HAWS warrants that this specific product is guaranteed against defective material or poor workmanship for a period of **one year from date of shipment**. HAWS liability under this warranty shall be discharged by furnishing without charge F.O.B. HAWS Factory any goods, or part thereof, which shall appear to the Company upon inspection to be of defective material or not of first class workmanship, provided that claim is made in writing to Haws within a reasonable period after receipt of the product. Where claims for defects are made, the defective part or parts shall be delivered to the Company, prepaid, for inspection. HAWS will not be liable for the cost of repairs, alterations or replacements, or for any expense connected therewith made by the owner or his agents, except upon written authority from HAWS, Sparks, Nevada. HAWS will not be liable for any damages caused by defective materials or poor workmanship, except for replacements, as provided above. Buyer agrees that HAWS shall not be liable for general, special, or consequential damages claimed to arise under the contract of sale. The drinking fountain manufactured by HAWS is warranted to function if installation and maintenance instructions provided are adhered to. The units also must be used for the purpose for which they were intended.

**NO OTHER WARRANTIES EXPRESSED OR IMPLIED ARE AUTHORIZED,
PROVIDED OR GIVEN BY HAWS.**

**SHOULD YOU EXPERIENCE DIFFICULTY WITH THE INSTALLATION OF THIS
MODEL PLEASE CALL:**

TECHNICAL SUPPORT: 1-800-766-5612

FOR CUSTOMER SERVICE: 1-888-640-4297

RECOMMENDED TOOLS: Hack saw, pipe joint sealant, screwdriver, level, 12" adjustable wrench, 10" pipe wrench, 5/64" hex key wrench, 9/16", 1/2", 7/16" socket wrench or open end wrench.

LOCATION OF UNIT: The Model 1311 Drinking Fountain is a wheelchair accessible drinking water facility. The height dimensions shown, meet current ADA requirements. When installing this unit, local, state or federal codes should be adhered to. If height other than shown is required, then dimensions must be adjusted accordingly.

SUPPLY LINE: The minimum recommended line size is 1/2"IPS with 30-90 psi (2-6 ATM) flowing pressure. Where sediment or mineral content is a problem, an inlet filter is recommended.

PLUMBING CONNECTIONS: Inlet is 3/8" O.D. tubing fitting. Waste trap outlet is 1-1/4" IPS.

MAINTENANCE: Periodically clean the strainer. Refer to 5874 Series Valve Manual for more information.

INSTALLATION PROCEDURE

GENERAL NOTES:

1. For all plastic push-in type fitting connections, only connect NSF-61 copper or plastic tubing. Stainless steel or glass tubing is not recommended. The following assembly instructions must be followed to ensure a watertight connection:
 - a. Cut tubing square and clean.
 - b. Mark from end of tube the length of insertion (See table below).
 - c. Push tube into the fitting until it bottoms out.
 - d. To remove, depress collet and pull tubing out.

Tube Sizes	O.D. Tolerance	Insertion Depth
1/4"	±.005"	11/16"
3/8"	±.005"	3/4"
1/2"	±.005"	7/8"

INSTALLATION PROCEDURE

Refer to Installation Drawing for mounting height. For steps below, refer to exploded view.

- STEP 1:** Remove hex lock nut and washers from bubbler heads, set aside. Install bubbler heads through receptor. Install respectively rubber washer, fiber washer, and then nut onto bubbler shank. Securely tighten nut.
- STEP 2:** Remove push button assembly from 5874 Series Valve with spanner wrench provided. Be sure to also remove (chrome plated) ring nut and (chrome plated) washer from valve. At this point, carefully follow installation instructions shown on page 5 of 5 of **5874 Series Valve/Push Button Operation and Maintenance Manual** under heading: **“INSTALLATION INSTRUCTIONS FOR 5874 Series Valve W/PBA6”**.
- STEP 3:** Make tubing connections from bubbler to the outlet side of control valve. Follow instructions for tubing preparation and insertion depths from Step 3.
- STEP 4:** Place strainer into receptor (using plumber’s putty), secure in place using a fiber washer and lock nut.
- STEP 5:** Mount fountain with appropriate hardware as shown on Installation Drawing.
- STEP 6:** Flush supply line to clear debris. Connect to a 1/2” NPT supply line and tighten.
- STEP 7:** Make certain that fountain is level and well secured to wall. Connect waste trap to a 1-1/4” IPS waste pipe (to be supplied by customer).
- STEP 8:** Completely open the screwdriver stop (not supplied) and check for leaks.
- STEP 9:** Adjust valves for desired flow height. See 5874 Series Valve Manual (supplied).
- STEP 10:** Attach bottom plate to fountain using #10-24 hardware provided.

TROUBLESHOOTING	
PROBLEM	REPAIR CHECKLIST
1. Insufficient bubbler flow.	1a. Check that inlet screwdriver stop valve is in wide-open position. b. Verify minimum 30 psi flowing supply pressure. c. Clean strainer. See 5874 Series Valve Manual. d. Adjust valve to increase flow. Use front adjust screw or see 5874 Series Valve Manual.

For more information on Haws Products, please see our website: www.hawsc.com

NOTES:

- 1 APPLY ONE DOT OF LOCTITE 222MS THREADLOCKER ON FEMALE THREADS OF PUSH BUTTON. SEE 5874 SERIES OPERATION AND MAINTENANCE MANUAL (PAGE 5 OF 5) FOR PROPER APPLICATION PROCEDURE.
- 2 5874PBF INCLUDES VRK5874 CARTRIDGE ASSEMBLY AND PBA6 FLANGED PUSHBUTTON.
- 3 REFER TO 5874 SERIES OPERATION AND MAINTENANCE MANUAL FOR INSTALLATION INSTRUCTIONS.
- 4 CONNECT CLEAR "POLYETHYLENE" TUBING ON FREE FLOW SIDE (VALVE TO BUBBLER HEAD) ONLY.

DRIVER, NOZZLE
.25 HEX PN
0002082253
(OPTIONAL) FOR
REMOVAL OF
NOZZLE WITH TUBE



VIEW A
ROTATED 90° CCW
DETAIL OF 5703M

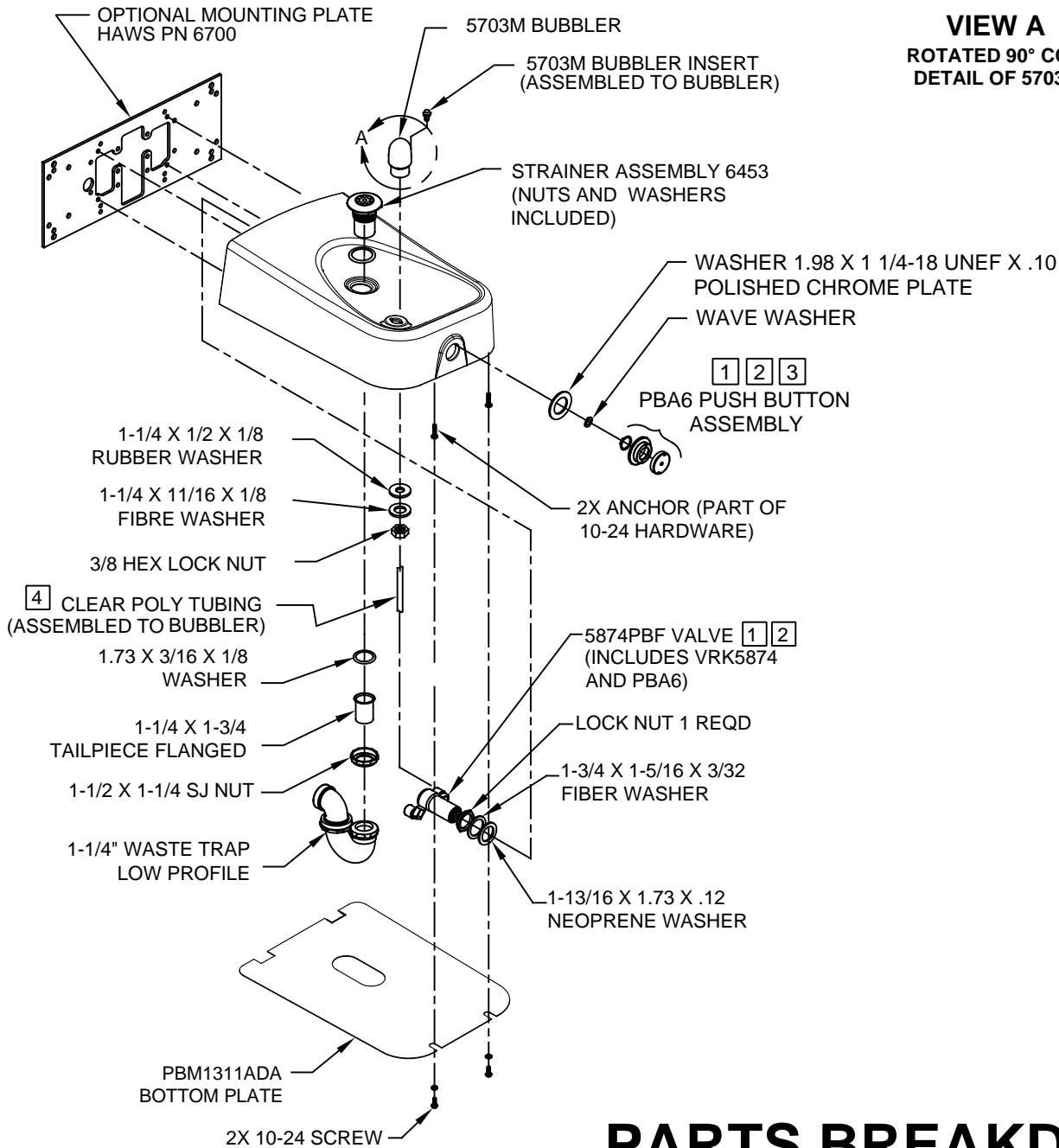

PARTS BREAKDOWN

		1455 KLEPPE LANE SPARKS, NEVADA 89431 (775) 359-4712 FAX (775) 359-7424 E-MAIL: HAWS@HAWSCO.COM WEBSITE: WWW.HAWSCO.COM	
		ECN NO. 5010 ECN: 5188 DRAWN HM APPROVED FV	REVISED PER VWC DATE 08/25/15 DATE 07/06/17
WHEN ORDERING PARTS PLEASE SPECIFY MODEL NUMBER.			
SCALE: 1:4		DRAWING TYPE: PARTS BREAKDOWN	SIZE: A SHEET 1 OF 1

1. HOLD ROUGH-IN DIMENSIONS $\pm 1/4"$ (6.4MM).
2. WHEN INSTALLING THIS UNIT, LOCAL, STATE, OR FEDERAL CODES SHOULD BE ADHERED TO. FOR INSTALLATION HEIGHTS OTHER THAN SHOWN, DIMENSIONS MARKED (*) MUST BE ADJUSTED ACCORDINGLY.
- 3 REFER TO 5874 SERIES VALVE OPERATION AND MAINTENANCE MANUAL FOR PUSH BUTTON AND VALVE INSTALLATION/MAINTENANCE INSTRUCTIONS.

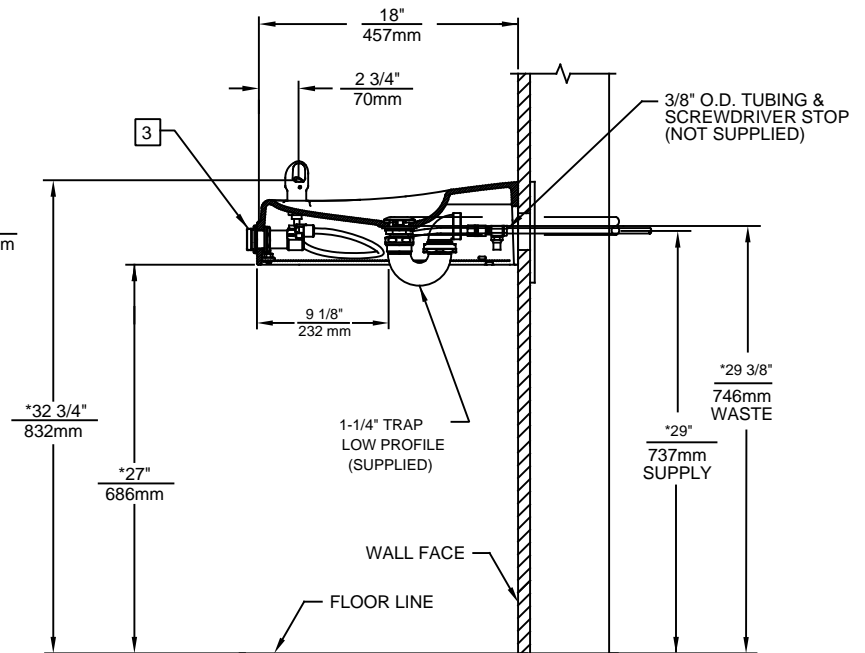
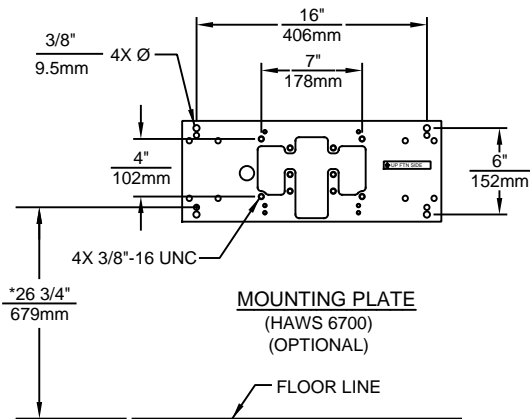
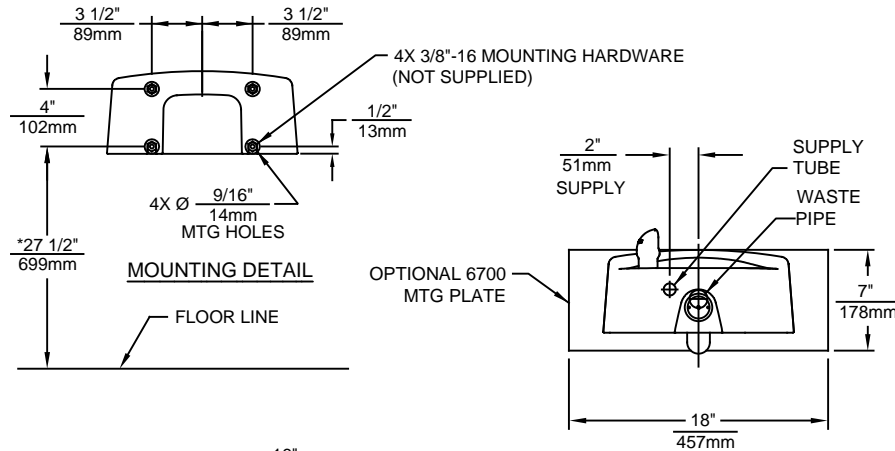
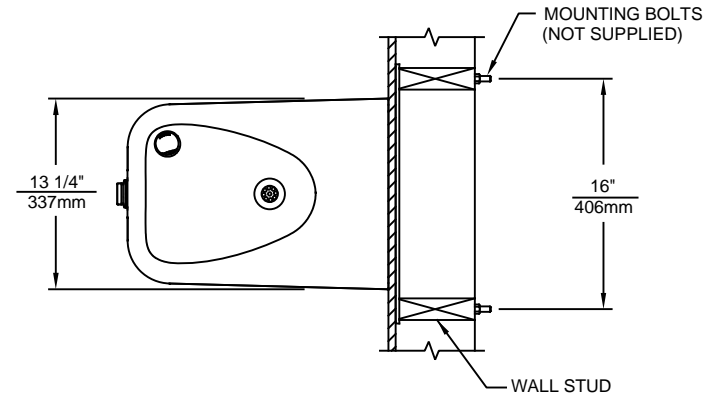

1455 KLEPPE LANE
 SPARKS, NEVADA 89431
 (775) 359-4712 FAX (775) 359-7424
 E-MAIL: HAWS@HAWSCO.COM
 WEBSITE: WWW.HAWSCO.COM

ECN NO. 5010	REVISED PER ECN: 5188	BY: JP	MODEL(S)	PART NUMBER
DRAWN: HM	DATE: 08/25/15	CHKD.: VWC	1311	051000046.D
APPROVED: FV	DATE: 07/06/17	SCALE: 1:14	DRAWING TYPE: INSTALLATION	REVISION 3
			SIZE: A	SHEET 1 OF 1