

No.	DESCRIPTION	MATERIAL
1	BODY	CAST LOW LEAD BRASS ALLOY
2	KEY	CAST LOW LEAD BRASS ALLOY
3	KEY WASHER	CAST BRASS ASTM B62 ALLOY C83600
4	KEY NUT	CAST BRASS ASTM B62 ALLOY C83600
5	COPPER TUBE NUT	CAST BRASS ASTM B62 ALLOY C83600

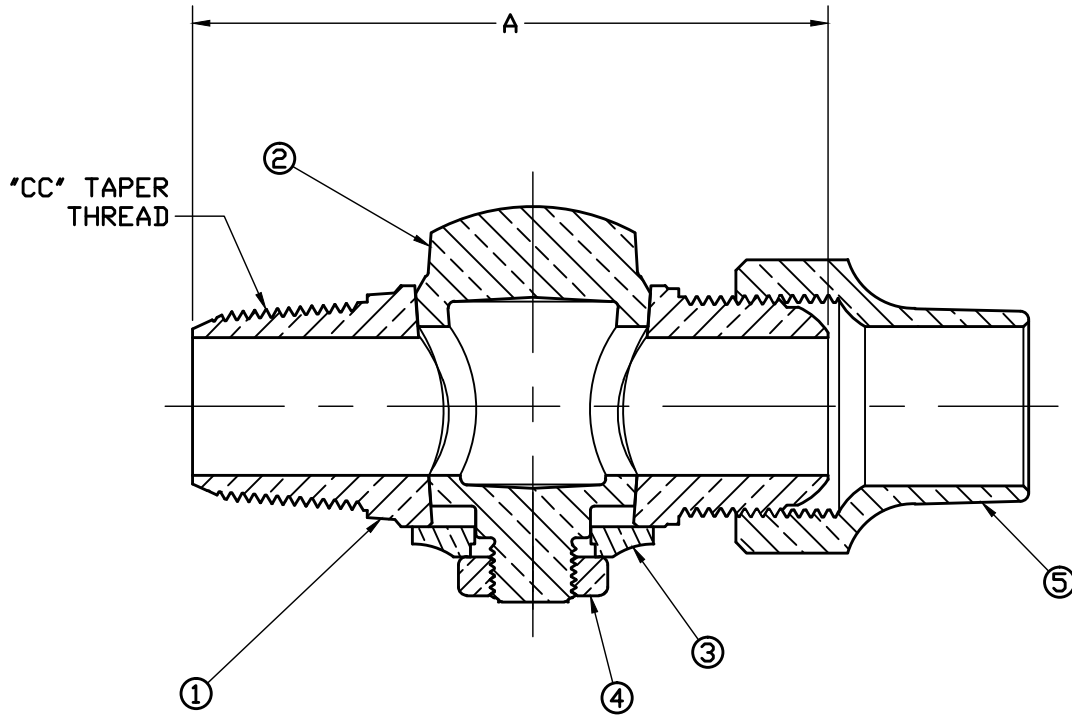

SIZE	A
3/4	3-27/32"
1	4-39/64"

FILEPATH: PRODD-ENG\JJ\SUBMITTALS\E1500

						DRFTR	JGarvin	9/25/09	JAMES JONES CO.		
						CHKR					
						ENGR					
						MGR					
							BY	DATE	UNLESS OTHERWISE NOTED	THIRD ANGLE PROJECTION	
									SURFACE PREPARATION:		
									BREAK CORNER(S) ---- .000		
									SURFACE FINISH -- 000 RMS	REF. No.	SCALE
									TOLERANCE(S):		FULL
									LINEAR ----- ± .000		
									ANGULAR ----- ± 0°00'		
									STK No:		
									MAT'L:		
									DESCR.		
									CORPORATION STOP	PART NUMBER	
									LOW LEAD BRASS ('CC' x CS)	E1500	
REV	ECR	DESCRIPTION	DATE	BY	CHKR						

PART NUMBER
E1500
JJ-MRKTG