

Socket Weld 90° Elbow

Specification: ASME B16.11

Material: Available in a complete range of Carbon Steels, Stainless Steels, Alloy Steels and Non-ferrous metals certified to ASTM, ASME, and Military standards.

Sizes: 1/8" - 4" in Class 3000 & 6000 • 1/8" - 3-1/2" in Class 9000
Also available in CL 10,000 and reducing pipe sizes and tube sizes

Socket Weld Pressure Class	Pipe Schedule
Class 3000	S80/XH
Class 6000	S160
Class 9000	XXH

Welding Gap and Minimum Flat Dimension for Socket Weld Fittings

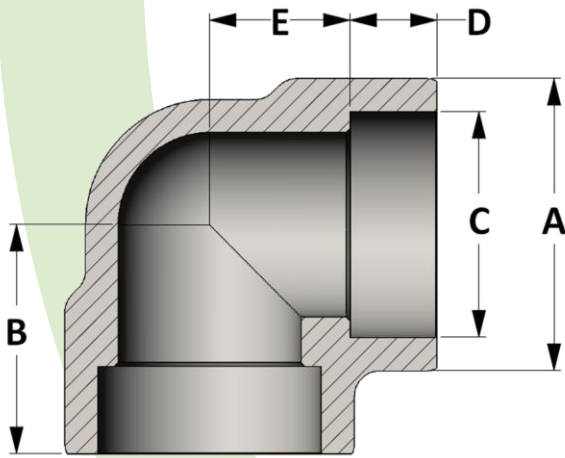
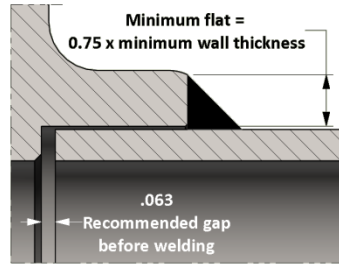

Active
3D
Model

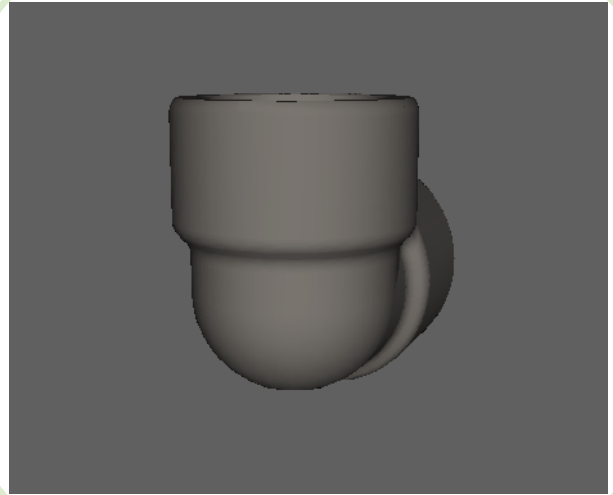

All dimensions are in inches • Weights are based on Carbon Steel

CLASS 3000 – Figure No. 13001

PIPE SIZE	1/8	1/4	3/8	1/2	3/4	1	1-1/4	1-1/2	2	2-1/2	3	4
A	0.875	0.875	1.063	1.313	1.500	1.813	2.188	2.500	3.000	3.625	4.313	5.875
B	0.875	0.875	0.969	1.125	1.313	1.500	1.750	2.000	2.375	3.000	3.375	4.188
C	0.426	0.560	0.693	0.859	1.071	1.335	1.682	1.922	2.410	2.910	3.536	4.545
D	0.438	0.438	0.438	0.500	0.563	0.625	0.688	0.750	0.875	1.375	1.125	1.566
E	0.438	0.438	0.531	0.625	0.750	0.875	1.063	1.250	1.500	1.625	2.250	2.625
LBS	0.20	0.17	0.24	0.48	0.68	1.06	1.72	2.33	3.88	7.34	10.40	22.47

CLASS 6000 – Figure No. 16001

PIPE SIZE	1/8	1/4	3/8	1/2	3/4	1	1-1/4	1-1/2	2	2-1/2	3	4
A	0.875	1.063	1.313	1.500	1.813	2.188	2.500	3.000	3.313	4.000	4.750	5.875
B	0.875	0.969	1.125	1.313	1.500	1.750	2.000	2.375	2.500	3.250	3.750	4.188
C	0.426	0.560	0.693	0.859	1.071	1.335	1.682	1.922	2.410	2.910	3.536	4.545
D	0.438	0.438	0.500	0.563	0.625	0.688	0.750	0.875	0.875	1.000	1.250	1.563
E	0.438	0.531	0.625	0.750	0.875	1.063	1.250	1.500	1.625	2.250	2.500	2.625
LBS	0.37	0.32	0.60	0.92	1.52	2.42	3.18	6.23	7.27	12.06	21.16	27.21

CLASS 9000 – Figure No. 19001

PIPE SIZE	1/8	1/4	3/8	1/2	3/4	1	1-1/4	1-1/2	2	2-1/2	3	4
A	1.063	1.313	1.500	1.813	2.188	2.500	3.000	3.313	3.625	4.313	5.875	---
B	0.969	1.125	1.313	1.500	1.750	2.000	2.375	2.500	3.000	3.375	4.188	---
C	0.426	0.560	0.693	0.859	1.071	1.335	1.682	1.922	2.410	2.910	3.536	---
D	0.438	0.500	0.500	0.500	0.625	0.750	1.000	1.000	0.875	1.000	1.313	---
E	0.531	0.625	0.813	1.000	1.125	1.250	1.375	1.500	2.125	2.375	2.875	---
LBS	0.41	0.70	1.12	1.73	2.91	4.15	6.79	8.96	12.39	19.78	42.20	---