

SPECIFICATIONS

FIGURE 7888 STRUT CHANNEL



1-5/8" x 13/16" 14 GA—HALF SLOT

FEATURES

- 1-5/8" x 13/16"
- 14-gauge channel
- Half slot
- Available in 10-ft. and 20-ft. lengths
- Materials:
 - Pre-galvanized steel (ASTM A653 SS Grade 33, G90)
 - Stainless Steel - Type 304 or 316/316L (ASTM A240)
- Available finishes:
 - Pre-galvanized steel (ASTM A653 SS Grade 33, G90)
 - Yellow "gold" zinc (Zinc Trivalent Chromium (ASTM B633))
 - Green powder-coated
 - Stainless steel - Type 304 or 316/316L (ASTM A240)
- Standard length tolerance $\pm 1/8"$
- Load data calculated based on ANSI/AISC 360-2016



Item #	Finish	Size		Length		Gauge
		in.	mm	ft	m	
FNWST7888S14Z2S1	Pre-Galv.	1-5/8 x 13/16	41 x 21	10	3.048	14
FNWST7888S14Z2S2	Pre-Galv.	1-5/8 x 13/16	41 x 21	20	6.096	14
FNWST7888S14Y2S1	Yellow	1-5/8 x 13/16	41 x 21	10	3.048	14
FNWST7888S14Y2S2	Yellow	1-5/8 x 13/16	41 x 21	20	6.096	14
FNWST7888S14G2S1	Green	1-5/8 x 13/16	41 x 21	10	3.048	14
FNWST7888S14G2S2	Green	1-5/8 x 13/16	41 x 21	20	6.096	14
FNWST7888S1442S1	304 SS	1-5/8 x 13/16	41 x 21	10	3.048	14
FNWST7888S1442S2	304 SS	1-5/8 x 13/16	41 x 21	20	6.096	14

SECTION PROPERTIES

Wt/Ft (lbs)	Area of Section Sq. In.	X-X Axis			Y-Y Axis		
		I in ⁴	S in ³	r in	I in ⁴	S in ³	r in
0.88	0.274	0.026	0.053	0.305	0.100	0.124	0.605

I = Moment of Inertia S = Section Modulus r = Radius of Gyration

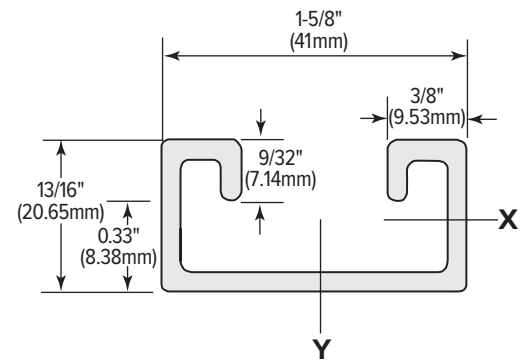

SPECIFICATIONS

FIGURE 7888
STRUT CHANNEL



1-5/8" x 13/16" 14 GA—HALF SLOT

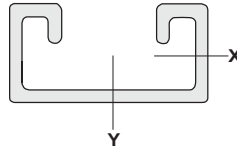

Span or Unbraced Height (In.)	Static Beam Load (X-X Axis)					Max Allowable Load at Slot Face (lbs)	Column Loading Data				Weight of Channel (lbs)
	Max Allowable Uniform Load (lbs)	Deflection at Uniform Load (In.)	Uniform Load at Deflection				Max Column Load				
			Span/180 Deflection (lbs)	Span/240 Deflection (lbs)	Span/360 Deflection (lbs)		k=.65 (lbs)	k=.80 (lbs)	k=1.0 (lbs)	k=1.2 (lbs)	
12	425	0.01	425	425	425	2966	9768	9196	8474	7797	0.88
18	286	0.03	286	286	286	2640	8562	7797	6838	5975	1.31
24	213	0.06	213	213	213	2341	7471	6538	5447	4523	1.75
30	172	0.09	172	172	163	2086	6477	5447	4347	3661	2.19
36	147	0.13	147	147	114	1830	5579	4523	3661	2939	2.62
42	123	0.17	123	123	82	1690	4805	3942	3045	2358	3.07
48	106	0.23	106	98	65	1531	4242	3397	2534	1927	3.49
60	90	0.35	82	65	41	1267	3335	2534	1804	**	4.37
72	73	0.51	58	49	NR	1030	2622	1927	**	**	5.24
84	65	0.69	41	NR	NR	**	2094	**	**	**	6.11
96	58	0.9	NR	NR	NR	**	**	**	**	**	6.99
108	49	1.14	NR	NR	NR	**	**	**	**	**	7.87
120	49	1.41	NR	NR	NR	**	**	**	**	**	8.74
144	41	2.03	NR	NR	NR	**	**	**	**	**	10.48
168	33	2.77	NR	NR	NR	**	**	**	**	**	12.24
180	33	3.18	NR	NR	NR	**	**	**	**	**	13.10
192	33	3.61	NR	NR	NR	**	**	**	**	**	13.98
216	24	4.57	NR	NR	NR	**	**	**	**	**	15.73
240	24	5.65	NR	NR	NR	**	**	**	**	**	17.47

NR = Not Recommended
** Not recommended - KL/r exceeds 200

NOTE: 1. Allowable beam loads are based on a uniformly loaded, simply supported beam. For capacities of a beam loaded at midspan at a single point, multiply the beam capacity by 50% and deflection by 80%. 2. The section properties (excluding quality) are in the absence of holes.