

# SPECIFICATIONS

## FIGURE 7881 STRUT CHANNEL



### 1-5/8" x 2-7/16" 12 GA-HALF SLOT

#### FEATURES

- 1-5/8" x 2-7/16"
- 12-gauge channel
- Half slot
- Load data calculated based on ANSI/AISC 360-2016
- Available lengths: 10 ft and 20 ft
- Material: Pre-galvanized steel (ASTM A653 SS Grade 33, G90)
- Standard length tolerance  $\pm 1/8"$
- Available finishes:
  - Pre-galvanized steel (ASTM A653 SS Grade 33, G90)
  - Green powder-coated



Catalog Number	Finish	Size		Length		Gauge
		in.	mm	ft	m	
FNWST7881S12Z2S1	Pre-galv.	1-5/8 x 2-7/16	41 x 62	10	3.048	12
FNWST7881S12Z2S2	Pre-galv.	1-5/8 x 2-7/16	41 x 62	20	6.096	12
FNWST7881S12G2S2	Green	1-5/8 x 2-7/16	41 x 62	20	6.096	12

#### SECTION PROPERTIES

Wt/Ft (lbs)	Area of Section Sq in.	X-X Axis			Y-Y Axis		
		I in <sup>4</sup>	S in <sup>3</sup>	r in	I in <sup>4</sup>	S in <sup>3</sup>	r in
2.28	0.696	0.516	0.386	0.860	0.322	0.397	0.680

I = Moment of Inertia S = Section Modulus r = Radius of Gyration

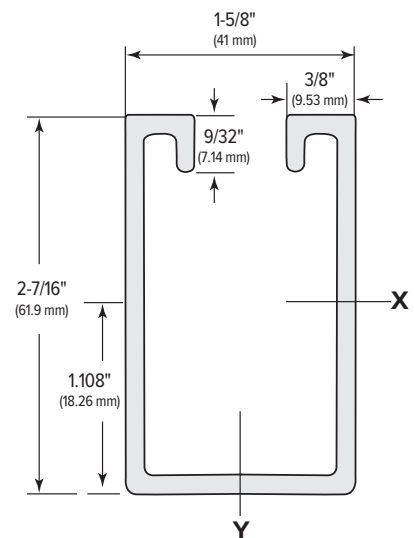

SPECIFICATIONS

**FIGURE 7881**  
STRUT CHANNEL



1-5/8" x 2-7/16" 12 GA-HALF SLOT

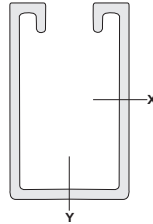

Span or Unbraced Height (in.)	Static Beam Load (X-X Axis)					Max Allowable Load at Slot Face (lbs)	Column Loading Data				Weight of Channel (lbs)
	Max Allowable Uniform Load (lbs)	Deflection at Uniform Load (in.)	Uniform Load at Deflection				Max Column Load				
			Span/180 Deflection (lbs)	Span/240 Deflection (lbs)	Span/360 Deflection (lbs)		k=.65 (lbs)	k=.80 (lbs)	k=1.0 (lbs)	k=1.2 (lbs)	
12	8385	0.01	8385	8385	8385	3441	10824	10674	10498	10155	2.28
18	5615	0.03	5615	5615	5615	3441	10498	10155	9671	9196	3.34
24	4213	0.06	4213	4213	4213	3397	9962	9478	8826	8219	4.44
30	3377	0.09	3377	3377	3131	3370	9478	8826	8043	7304	5.56
36	2828	0.13	2828	2828	2172	3326	8932	8219	7304	6538	6.67
42	2394	0.17	2394	2394	1598	3265	8386	7638	6618	5764	7.78
48	2107	0.23	2107	1836	1221	3194	7876	7075	6046	5078	8.89
60	1672	0.35	1566	1180	787	3018	6996	6046	4910	4083	11.11
72	1385	0.51	1090	820	550	2719	6107	5078	4083	3370	13.33
84	1188	0.69	803	598	401	2446	5386	4347	3467	2772	15.55
96	1033	0.9	615	459	311	2226	4690	3828	2957	2279	17.78
108	926	1.14	483	369	246	2024	4206	3370	2517	1918	20.00
120	836	1.41	393	295	197	1804	3766	2957	2147	**	22.23
144	697	2.03	278	205	140	1443	3045	2279	**	**	26.67
168	598	2.77	205	156	106	1179	2473	1804	**	**	31.11
180	557	3.18	181	131	90	**	2235	**	**	**	33.33
192	533	3.61	156	115	82	**	2024	**	**	**	35.56
216	468	4.57	123	99	65	**	**	**	**	**	40.00
240	418	5.65	99	74	49	**	**	**	**	**	44.44

NR = Not Recommended  
\*\* Not recommended - KL/r exceeds 200

NOTE: 1. Allowable beam loads are based on a uniformly loaded, simply supported beam. For capacities of a beam loaded at midspan at a single point, multiply the beam capacity by 50% and deflection by 80%. 2. The section properties (excluding quality) are in the absence of holes.