

# SPECIFICATIONS

## FIGURE 7882 STRUT CHANNEL



### 1-5/8" x 1-5/8" 12 GA-BACK-TO-BACK HALF SLOT

#### FEATURES

- 1-5/8" x 1-5/8"
- 12-gauge channel
- Back-to-back half slot
- Available in 10-ft. and 20-ft. lengths
- Material: Pre-galvanized steel (ASTM A653 SS Grade 33, G90)
- Available finishes:
  - Pre-galvanized steel (ASTM A653 SS Grade 33, G90)
  - Yellow "gold" zinc (Zinc Trivalent Chromium (ASTM B633))
  - Green powder-coated
- Standard length tolerance  $\pm 1/8"$
- Load data calculated based on ANSI/AISC 360-2016



Item #	Finish	Size		Length		Gauge
		in.	mm	ft	m	
FNWST7882B12Z2S1	Pre-Galv.	1-5/8 x 1-5/8	41 x 41	10	3.048	12
FNWST7882B12Z2S2	Pre-Galv.	1-5/8 x 1-5/8	41 x 41	20	6.096	12
FNWST7882B12G2S1	Green	1-5/8 x 1-5/8	41 x 41	10	3.048	12
FNWST7882B12G2S2	Green	1-5/8 x 1-5/8	41 x 41	20	6.096	12
FNWST7882B12Y2S2	Yellow	1-5/8 x 1-5/8	41 x 41	20	6.096	12

#### SECTION PROPERTIES

Wt/Ft (lbs)	Area of Section Sq. In.	X-X Axis			Y-Y Axis		
		I in <sup>4</sup>	S in <sup>3</sup>	r in	I in <sup>4</sup>	S in <sup>3</sup>	r in
3.46	1.070	0.939	0.578	0.937	0.456	0.561	0.623

I = Moment of Inertia S = Section Modulus r = Radius of Gyration

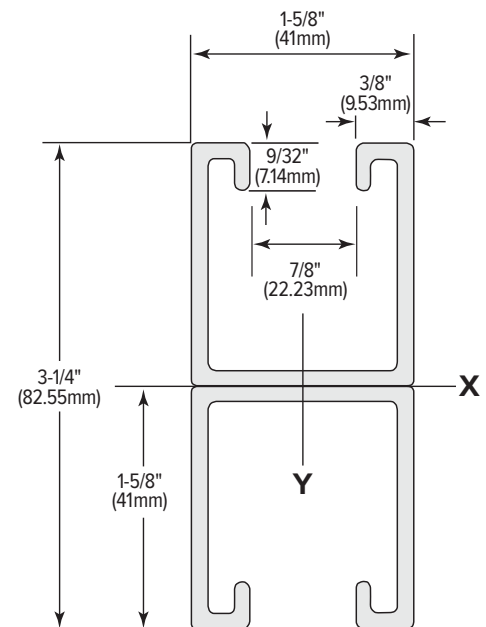

SPECIFICATIONS

**FIGURE 7882**  
STRUT CHANNEL



1-5/8" x 1-5/8" 12 GA-BACK-TO-BACK HALF SLOT

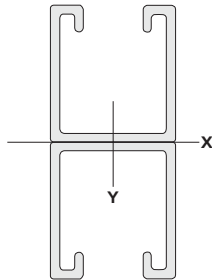

Span or Unbraced Height (in.)	Static Beam Load (X-X Axis)					Max Allowable Load at Slot Face (lbs)	Column Loading Data				Weight of Channel (lbs)
	Max Allowable Uniform Load (lbs)	Deflection at Uniform Load (in.)	Uniform Load at Deflection				Max Column Load				
			Span/180 Deflection (lbs)	Span/240 Deflection (lbs)	Span/360 Deflection (lbs)		k=.65 (lbs)	k=.80 (lbs)	k=1.0 (lbs)	k=1.2 (lbs)	
12	15256	0.01	15256	15256	15256	3441	10824	10674	10446	10058	3.46
18	10214	0.03	10214	10214	10214	3406	10498	10058	9574	9020	5.18
24	7656	0.06	7656	7656	7656	3362	9962	9381	8738	8043	6.91
30	6148	0.09	6148	6148	5689	3344	9381	8738	7876	7146	8.64
36	5140	0.13	5140	5140	3952	3256	8826	8043	7146	6318	10.37
42	4362	0.17	4362	4362	2910	3194	8307	7471	6477	5579	12.10
48	3836	0.23	3836	3337	2230	3124	7797	6917	5843	4910	13.82
60	3033	0.35	2845	2140	1426	2913	6838	5843	4690	3942	17.28
72	2524	0.51	1976	1484	992	2631	5975	4910	3942	3212	20.73
84	2164	0.69	1459	1090	729	2367	5201	4206	3300	2622	24.18
96	1877	0.9	1115	837	557	2147	4523	3696	2798	2174	27.64
108	1689	1.14	885	664	442	1927	4048	3212	2385	1795	31.09
120	1517	1.41	714	541	361	1707	3634	2798	2024	**	34.55
144	1262	2.03	500	377	254	1382	2904	2174	**	**	41.46
168	1082	2.77	369	279	188	**	2341	**	**	**	48.37
180	1008	3.18	320	238	164	**	2121	**	**	**	51.83
192	959	3.61	279	213	140	**	1918	**	**	**	55.27
216	837	4.57	222	172	115	**	**	**	**	**	62.19
240	755	5.65	181	140	90	**	**	**	**	**	69.10

NR = Not Recommended  
 \*\* Not recommended - KL/r exceeds 200

NOTE: 1. Allowable beam loads are based on a uniformly loaded, simply supported beam. For capacities of a beam loaded at midspan at a single point, multiply the beam capacity by 50% and deflection by 80%. 2. The section properties (excluding quality) are in the absence of holes.