

SPECIFICATIONS

FIGURE 7887 STRUT CHANNEL



1-5/8" x 13/16" 12 GA-HALF SLOT

FEATURES

- 1-5/8" x 13/16"
- 12-gauge channel
- Half slot
- Available in 10-ft. and 20-ft. lengths
- Material: Pre-galvanized steel (ASTM A653 SS Grade 33, G90)
- Available finishes:
 - Pre-galvanized steel (ASTM A653 SS Grade 33, G90)
 - Green powder-coated
- Standard length tolerance $\pm 1/8"$
- Load data calculated based on ANSI/AISC 360-2016

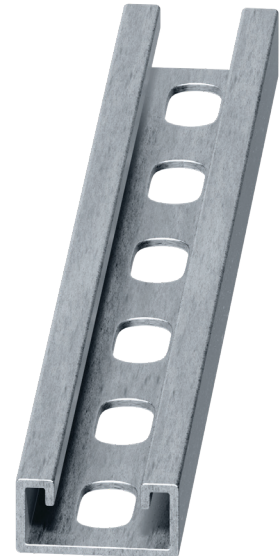

Item #	Finish	Size		Length		Gauge
		in.	mm	ft	m	
FNWST7887S12Z2S1	Pre-Galv.	1-5/8 x 13/16	41 x 21	10	3.048	12
FNWST7887S12Z2S2	Pre-Galv.	1-5/8 x 13/16	41 x 21	20	6.096	12
FNWST7887S12G2S1	Green	1-5/8 x 13/16	41 x 21	10	3.048	12
FNWST7887S12G2S2	Green	1-5/8 x 13/16	41 x 21	20	6.096	12

SECTION PROPERTIES

Wt/Ft (lbs)	Area of Section Sq. In.	X-X Axis			Y-Y Axis		
		I in ⁴	S in ³	r in	I in ⁴	S in ³	r in
1.2	0.373	0.033	0.068	0.297	0.134	0.165	0.599

I = Moment of Inertia S = Section Modulus r = Radius of Gyration

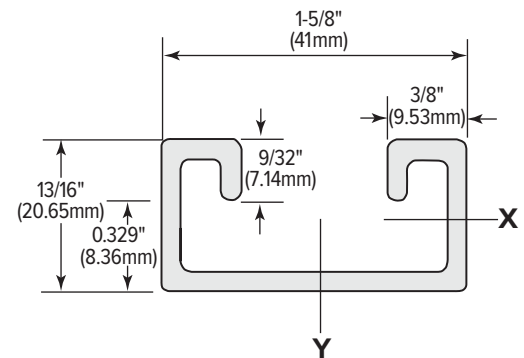

SPECIFICATIONS

FIGURE 7887
STRUT CHANNEL



1-5/8" x 13/16" 12 GA-HALF SLOT

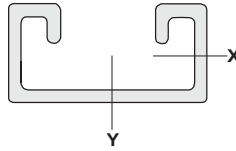

Span or Unbraced Height (in.)	Static Beam Load (X-X Axis)					Max Allowable Load at Slot Face (lbs)	Column Loading Data				Weight of Channel (lbs)
	Max Allowable Uniform Load (lbs)	Deflection at Uniform Load (in.)	Uniform Load at Deflection				Max Column Load				
			Span/180 Deflection (lbs)	Span/240 Deflection (lbs)	Span/360 Deflection (lbs)		k=.65 (lbs)	k=.80 (lbs)	k=1.0 (lbs)	k=1.2 (lbs)	
12	539	0.01	539	539	539	2939	9671	9108	8386	7709	1.20
18	365	0.03	365	365	365	2614	8474	7709	6697	5843	1.80
24	273	0.06	273	273	273	2297	7304	6398	5324	4435	2.41
30	224	0.09	224	224	207	2033	6318	5324	4242	3529	3.02
36	183	0.13	183	183	141	1795	5447	4435	3529	2825	3.61
42	157	0.17	157	157	107	1628	4690	3802	2939	2262	4.22
48	141	0.23	141	124	83	1478	4083	3274	2429	1848	4.81
60	107	0.35	107	83	58	1214	3212	2429	**	**	6.02
72	91	0.51	74	58	41	986	2517	1848	**	**	7.22
84	83	0.69	58	41	NR	**	2006	**	**	**	8.42
96	66	0.9	41	NR	NR	**	**	**	**	**	9.63
108	66	1.14	NR	NR	NR	**	**	**	**	**	10.83
120	58	1.41	NR	NR	NR	**	**	**	**	**	12.03
144	50	2.03	NR	NR	NR	**	**	**	**	**	14.44
168	41	2.77	NR	NR	NR	**	**	**	**	**	16.85
180	41	3.18	NR	NR	NR	**	**	**	**	**	18.05
192	41	3.61	NR	NR	NR	**	**	**	**	**	19.25
216	33	4.57	NR	NR	NR	**	**	**	**	**	21.66
240	33	5.65	NR	NR	NR	**	**	**	**	**	24.06

NR = Not Recommended
** Not recommended - KL/r exceeds 200

NOTE: 1. Allowable beam loads are based on a uniformly loaded, simply supported beam. For capacities of a beam loaded at midspan at a single point, multiply the beam capacity by 50% and deflection by 80%. 2. The section properties (excluding quality) are in the absence of holes.