

# SPECIFICATIONS

## FIGURE 7888 STRUT CHANNEL



1-5/8" x 13/16" 14 GA-SOLID

### FEATURES

- 1-5/8" x 13/16"
- 14-gauge channel
- Solid
- Available in 10-ft. length only
- Material: Pre-galvanized steel (ASTM A653 SS Grade 33, G90)
- Available finishes:
  - Pre-galvanized steel (ASTM A653 SS Grade 33, G90)
  - Yellow "gold" zinc (Zinc Trivalent Chromium (ASTM B633))
  - Green powder-coated
- Standard length tolerance  $\pm 1/8"$
- Load data calculated based on ANSI/AISC 360-2016

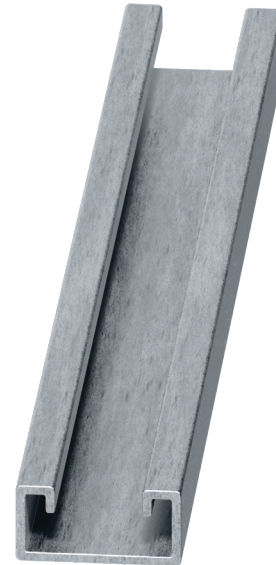

Item #	Finish	Size		Length		Gauge
		in.	mm	ft	m	
FNWST7888S14ZSD1	Pre-Galv.	1-5/8 x 13/16	41 x 21	10	3.048	14
FNWST7888S14YSD1	Yellow	1-5/8 x 13/16	41 x 21	10	3.048	14
FNWST7888S14GSD2	Green	1-5/8 x 13/16	41 x 21	10	3.048	14

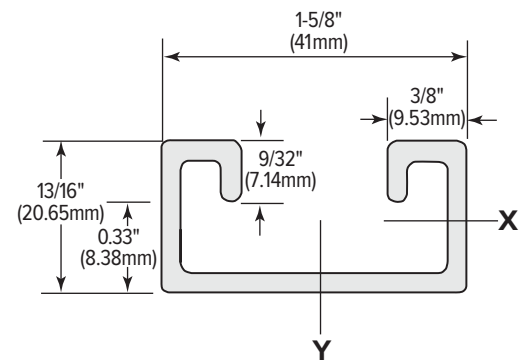

### SECTION PROPERTIES

Wt/Ft (lbs)	Area of Section Sq. In.	X-X Axis			Y-Y Axis		
		I in <sup>4</sup>	S in <sup>3</sup>	r in	I in <sup>4</sup>	S in <sup>3</sup>	r in
0.93	0.274	0.026	0.053	0.305	0.100	0.124	0.605

I = Moment of Inertia S = Section Modulus r = Radius of Gyration

SPECIFICATIONS

**FIGURE 7888**  
STRUT CHANNEL



1-5/8" x 13/16" 14 GA-SOLID

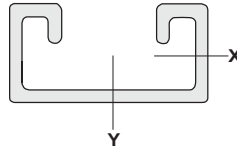

Span or Unbraced Height (in.)	Static Beam Load (X-X Axis)					Max Allowable Load at Slot Face (lbs)	Column Loading Data				Weight of Channel (lbs)
	Max Allowable Uniform Load (lbs)	Deflection at Uniform Load (in.)	Uniform Load at Deflection				Max Column Load				
			Span/180 Deflection (lbs)	Span/240 Deflection (lbs)	Span/360 Deflection (lbs)		k=.65 (lbs)	k=.80 (lbs)	k=1.0 (lbs)	k=1.2 (lbs)	
12	483	0.01	483	483	483	3370	11100	10450	9630	8860	0.93
18	325	0.03	325	325	325	3000	9730	8860	7770	6790	1.40
24	241	0.06	241	241	241	2660	8490	7430	6190	5140	1.86
30	195	0.09	195	195	186	2370	7360	6190	4940	4160	2.33
36	167	0.13	167	167	130	2080	6340	5140	4160	3340	2.79
42	139	0.17	139	139	93	1920	5460	4480	3460	2680	3.26
48	121	0.23	121	111	74	1740	4820	3860	2880	2190	3.73
60	102	0.35	93	74	46	1440	3790	2880	2050	**	4.66
72	84	0.51	65	56	40	1170	2980	2190	**	**	5.59
84	74	0.69	46	40	NR	**	2380	**	**	**	6.52
96	65	0.9	40	NR	NR	**	**	**	**	**	7.45
108	56	1.14	NR	NR	NR	**	**	**	**	**	8.38
120	56	1.41	NR	NR	NR	**	**	**	**	**	9.31
144	46	2.03	NR	NR	NR	**	**	**	**	**	11.18
168	37	2.77	NR	NR	NR	**	**	**	**	**	13.04
180	37	3.18	NR	NR	NR	**	**	**	**	**	13.97
192	37	3.61	NR	NR	NR	**	**	**	**	**	14.90
216	28	4.57	NR	NR	NR	**	**	**	**	**	16.77
240	28	5.65	NR	NR	NR	**	**	**	**	**	18.63

NR = Not Recommended  
\*\* Not recommended - KL/r exceeds 200

NOTE: 1. Allowable beam loads are based on a uniformly loaded, simply supported beam. For capacities of a beam loaded at midspan at a single point, multiply the beam capacity by 50% and deflection by 80%.