

TECHNICAL SPECIFICATIONS

SHT-60

MODEL NUMBER 141032

DIMENSIONS: 60" x 35" x 72 1/4" Gelcoat



STANDARD FEATURES

- One-piece gelcoated fiberglass shower with 6 inch simulated tile pattern
- Built-in back wall shelves
- Twin seats
- Center drain
- Textured floor

UNIQUE FEATURES

- None

OPTIONS

- None

SYSTEMS

- None

DOOR SELECTION

Combine with AKER's complete shower door offering visit www.akerbymax.com

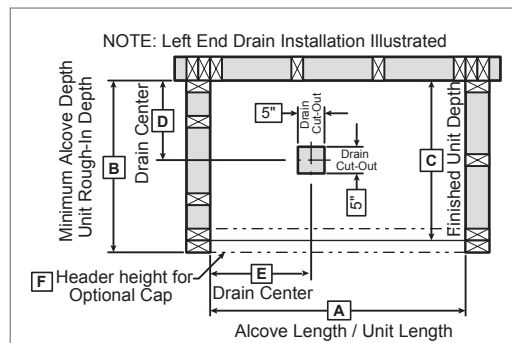

Model	A	B	C	D	E
141032	60"	36 1/2"	35"	17 1/4"	30"

Project :

Contractor :

AKER Representative : Tel :

Date :

CERTIFICATIONS

AKER products adhere to one or more of the following certifications:



TECHNICAL SPECIFICATIONS

SHT-60

MODEL NUMBER 141032

TECHNICAL DRAWINGS

