

TECHNICAL SPECIFICATIONS

S-60

MODEL NUMBER 141029

DIMENSIONS: 60" x 35 1/2" x 74 1/2" Gelcoat



STANDARD FEATURES

- One-piece gelcoated fiberglass shower with optional roofcap
- Built-in corner shelves
- Twin seats
- Center drain
- Textured floor

UNIQUE FEATURES

- None

OPTIONS

- Gelcoated fiberglass cap
- Light for roofcap (factory-drilled hole)

SYSTEMS

- None

DOOR SELECTION

Combine with AKER's complete shower door offering visit www.akerbymaax.com

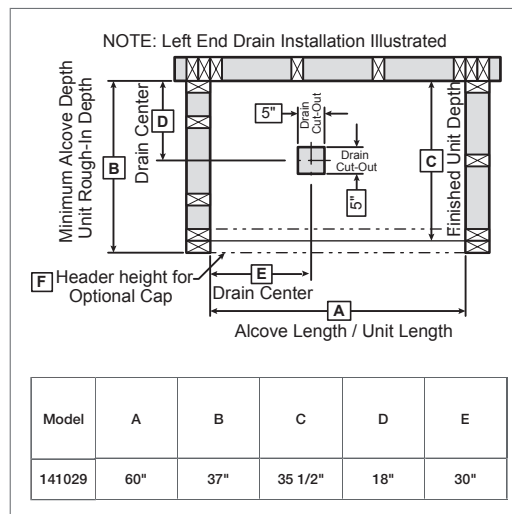

Project :

Contractor :

AKER Representative : Tel :

Date :

CERTIFICATIONS

AKER products adhere to one or more of the following certifications:



TECHNICAL SPECIFICATIONS

S-60

MODEL NUMBER 141029

TECHNICAL DRAWINGS

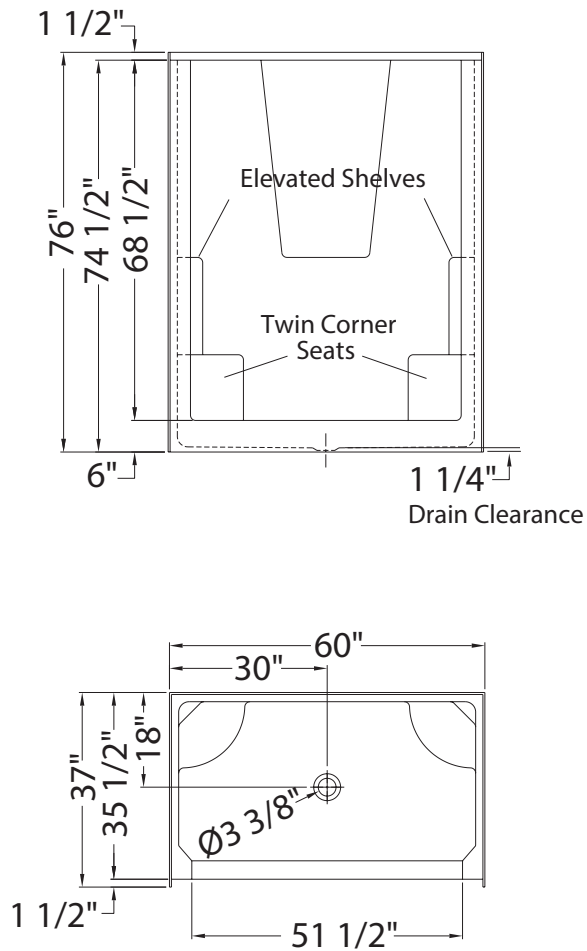

All dimensions are approximate. Structure measurements must be verified against the unit to ensure proper fit.