

DOUBLE FLOAT® MASTER Pump Switch

Mechanically activated switch designed to control pumps up to 15 FLA, 90 LRA, 120 VAC or 240 VAC.

This mechanically activated, pump switch provides automatic control of pumps in non-potable water and sewage applications. It is well-suited for confined applications requiring an accurate pumping range. It is not sensitive to rotation or turbulence. This switch is voltage sensitive - use with correct voltage.

The **Double Float® Master** pump switch consists of two mechanical floats and a splice tube. The splice tube contains a holding relay which enables the floats to function in series.

The holding relay eliminates pump chatter in turbulent conditions allowing the **Double Float® Master** pump switch to operate relay control panels for larger pump applications.



FEATURES

- Controls pumps up to 15 FLA, 90 LRA, 120 VAC or 240 VAC.
- Adjustable pumping range of 3 to 48 inches (7.6 to 122 cm) with increased pumping range up to 6 feet (1.8 meters) available.
- Includes standard mounting clamps and boxed packaging.
- CSA Certified.
- Three-year limited warranty.



Pump Down Schematic

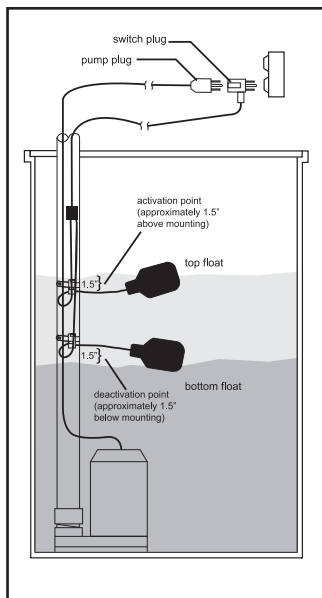
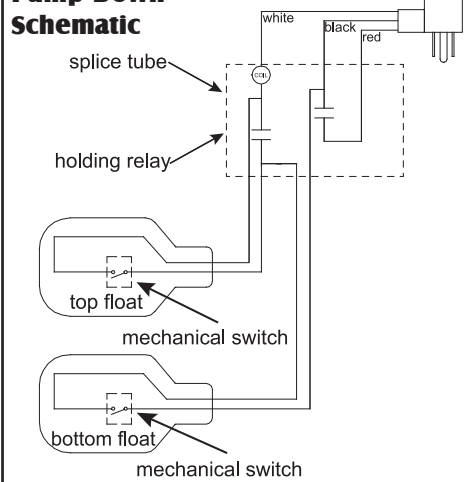

SPECIFICATIONS

Cable attached to float housing: flexible 18 gauge, 2 conductor (UL, CSA) SJOW, water-resistant (CPE)

Cable above splice: flexible 14 gauge, 3 conductor (UL, CSA) SJTW, water-resistant, thermoplastic

FLOATS: 2.74 inch diameter x 4.83 inch long (7.0 x 12.3 cm) high impact, corrosion resistant, PP housing for use in sewage and non-potable water up to 140°F (60°C)

ELECTRICAL:

120 VAC 50/60Hz Single Phase:

Maximum Pump Running Current (FLA):
15 amps

Maximum Pump Starting Current (LRA):
90 amps

240 VAC 50/60Hz Single Phase:

Maximum Pump Running Current (FLA):
15 amps

Maximum Pump Starting Current (LRA):
90 amps

NOTE: This switch must be used with pumps that provide integral thermal overload protection.

OPTIONS

This switch is available:

- for pump down or pump up applications as specified by part number.
- with a 120 VAC or 240 VAC piggy-back plug.
- without a plug for direct wiring (120 VAC units can only be used with 120 VAC applications within specified amp ratings. 240 VAC units can only be used with 240 VAC applications within specified amp ratings).
- in standard cable lengths of 15, 20, or 30 feet and 5 or 10 meters (longer lengths available).

SEE BACKSIDE FOR ORDERING INFORMATION.

SJE
Rhombus

PO Box 1708, Detroit Lakes, MN 56502

1-888-DIAL-SJE • 1-218-847-1317

1-218-847-4617 Fax

email: sje@sjerhombus.com

www.sjerhombus.com

PUMP SWITCHES
(MECHANICAL)

DOUBLE FLOAT® MASTER Pump Switch

Mechanically activated switch designed to control pumps up to 15 FLA, 90 LRA, 120 VAC or 240 VAC.

ORDERING INFORMATION

PUMP DOWN ↓		PUMP UP ↑		List Price	Shipping Weight
Part #	Description	Part #	Description		
1016864	15DFMMD1WP	1017668	15DFMMU1WP	\$129.47	3.63 lbs.
1017657	15DFMMD2WP	1017669	15DFMMU2WP	\$132.96	3.64 lbs.
1017658	15DFMMD1WOP	1017670	15DFMMU1WOP	\$121.81	3.55 lbs.
1017659	15DFMMD2WOP	1017671	15DFMMU2WOP	\$124.38	3.51 lbs.
1017660	20DFMMD1WP	1017672	20DFMMU1WP	\$134.31	4.04 lbs.
1017661	20DFMMD2WP	1017673	20DFMMU2WP	\$137.79	4.08 lbs.
1017662	20DFMMD1WOP	1017674	20DFMMU1WOP	\$126.66	3.97 lbs.
1017663	20DFMMD2WOP	1017675	20DFMMU2WOP	\$129.20	4.01 lbs.
1017664	30DFMMD1WP	1017676	30DFMMU1WP	\$144.63	4.95 lbs.
1017665	30DFMMD2WP	1017677	30DFMMU2WP	\$148.12	4.99 lbs.
1017666	30DFMMD1WOP	1017678	30DFMMU1WOP	\$137.11	4.86 lbs.
1017667	30DFMMD2WOP	1017679	30DFMMU2WOP	\$139.53	4.87 lbs.

OPTIONS

PACKAGING

Boxed - Standard
Bagged - Specify and deduct 40¢ from list price.

Bulk - Specify and deduct 60¢ from list price.

ADDITIONAL CABLE

Additional cable length over 30 feet is available at \$1.60 per foot (list price).



D = Pump Down U = Pump Up 1 = 120 VAC 2 = 240 VAC

WP = With Plug WOP = With Out Plug

NOTE: Descriptions are grouped by cable length measured in feet (15, 20, 30).

SPECIFICATIONS

PUMPING RANGE: 3 to 48 inches (7.6 cm to 122 cm), increased pumping range available. Call factory for quote.

CABLE ATTACHED TO FLOAT HOUSING: flexible 18 gauge, 2 conductor (UL, CSA) SJOW, water-resistant (CPE)

CABLE ABOVE SPLICE: flexible 14 gauge, 3 conductor (UL, CSA) SJTW, water-resistant thermoplastic

FLOAT: 2.74 inch diameter x 4.83 inch long (7.0 cm x 12.3 cm), high impact, corrosion resistant, PP housing for use in sewage and non-potable water up to 140°F (60°C)

ELECTRICAL:

Voltage 50Hz/60Hz Single Phase	Max. Pump Run Current	Max. Pump Start Current
120 VAC	15 amps	90 amps
240 VAC	15 amps	90 amps

NOTE: This switch must be used with pumps that provide integral thermal overload protection.

OTHER INFORMATION

PUMP DOWN is normally open contacts for emptying.

PUMP UP is normally closed contacts for filling.

DIRECT WIRING

120 VAC units used for direct wiring (without plug) can **only** be used with **120 VAC** applications within specified amp ratings.

240 VAC units used for direct wiring (without plug) can **only** be used with **240 VAC** applications within specified amp ratings.



www.sjrhombus.com
 sje@sjrhombus.com

Cat Page PN 1017737M
 © SJE-Rhombus 06/11

Call or fax your order!

1-888-DIAL-SJE (1-888-342-5753) ■ Fax 218-847-4617