

Installation Instructions / Warranty

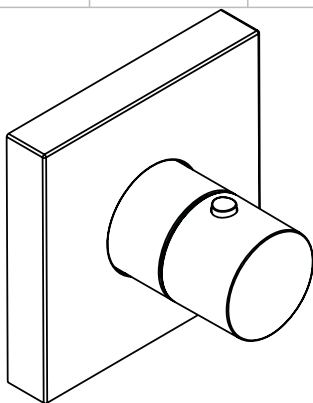

Starck
10755XX1

AXOR[®]
hansgrohe

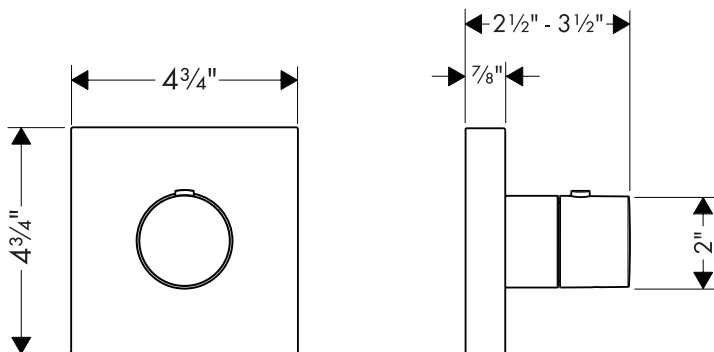

Technical Information

Recommended water pressure	15 - 75 psi
Max. water pressure	145 psi
Recommended hot water temp.	120°-140° F*
Max. hot water temp	176° F*
Flow rate	14.5 gpm
Thermostatic cartridge with high temperature limit stop	

*Please know and follow all applicable local plumbing codes when setting the temperature on the water heater.

Installation Considerations

- For best results, Hansgrohe recommends that this unit be installed by a licensed, professional plumber.
- Please read over these instructions thoroughly before beginning installation. Make sure that you have all tools and supplies needed to complete the installation.
- This trim is for use with Axor Starck thermostatic mixer rough 10754181.
- The high temperature limit stop can be reset to comply with local plumbing codes. See page 7.
- To prevent scalding, the maximum output temperature of the shower valve must be no higher than 120°. In Massachusetts, the maximum output temperature of the shower valve can be no higher than 112°F.
- The valve includes check valves that should be inspected at least once per year.
- Keep this booklet and the receipt (or other proof of date and place of purchase) for this product in a safe place. The receipt is required should it be necessary to request warranty parts.

Installation

Cut the plaster shield so that it extends $\frac{1}{16}$ " outside the surface of the finished wall.

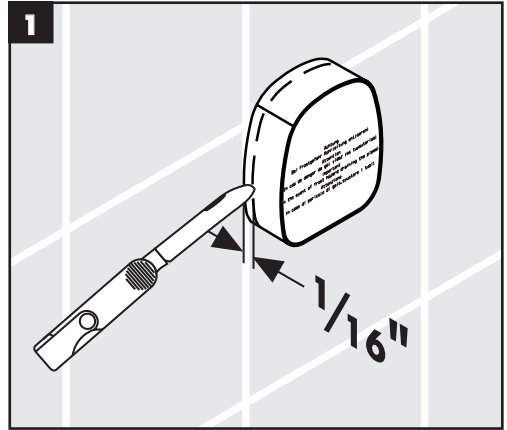

 Seal the wall around the i-box with waterproof sealant.

 Failure to seal the wall can lead to possible water damage.

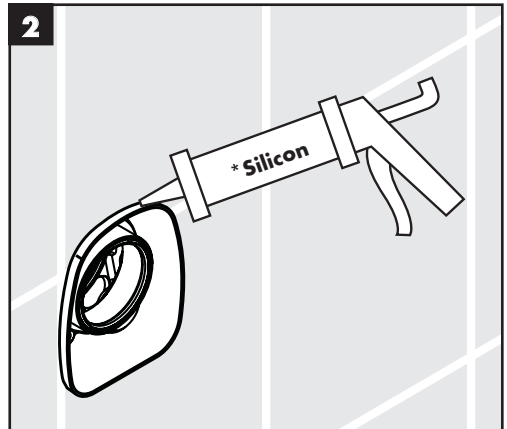

Remove the plug using a 17 mm wrench.

Remove the flush insert using a 27 mm wrench.

Remove the check valve covers.

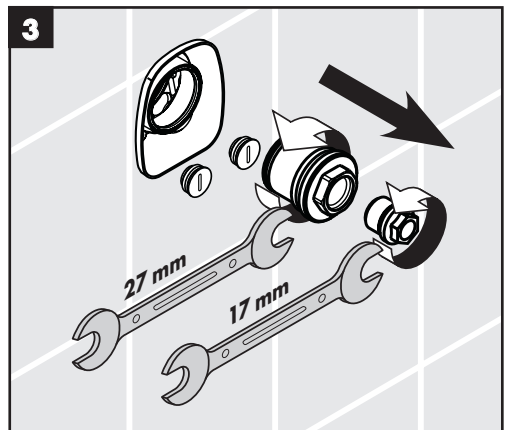

Insert the filters and the check valves.

Install the check valve covers.

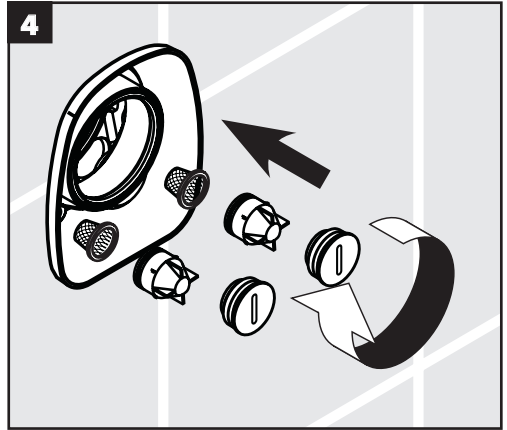

Install the thermostatic mixing cartridge.

Tighten the cartridge using a 24 mm wrench.

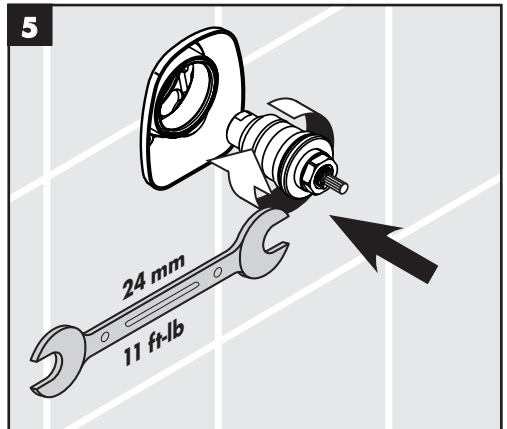

Install the sleeve.

Install the escutcheon carrier plate.

Install the carrier plate screws.

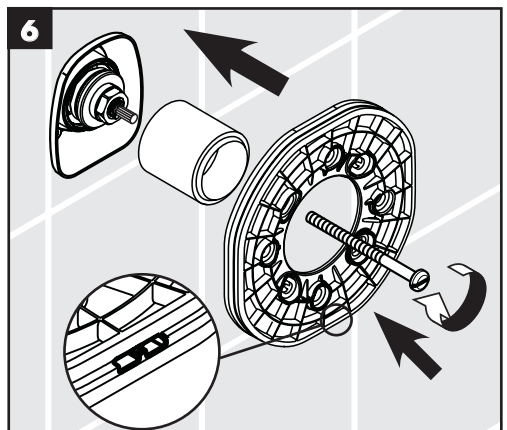

Inspect the screws.

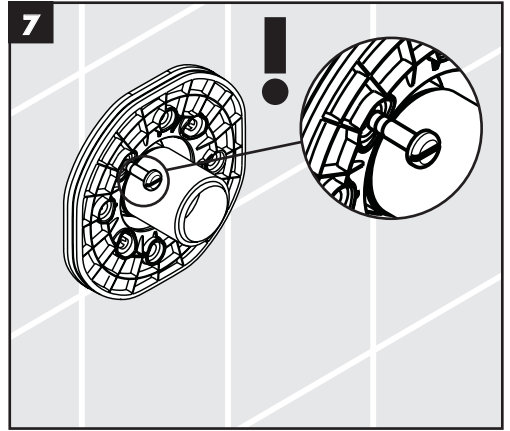

If the screws are too long, remove them (1).

Shorten the screws (2).

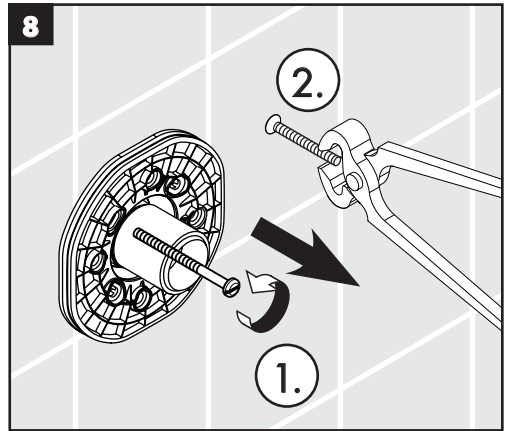

Reinstall the screws.

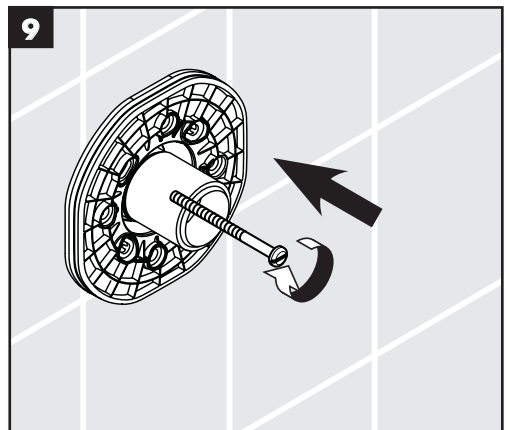

Install the safety set.

Install the stem extension and screw.

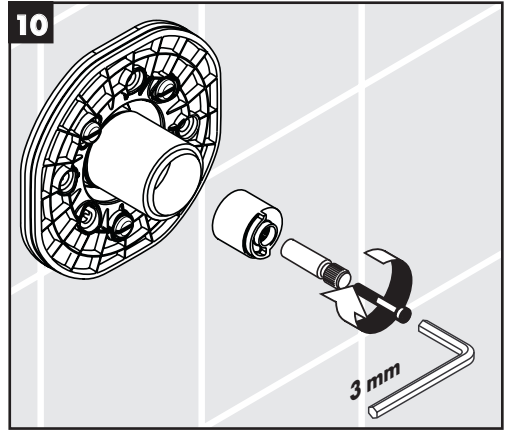

Install the escutcheon.

Install the handle.

Tighten the handle screw using a 2 mm Allen wrench.

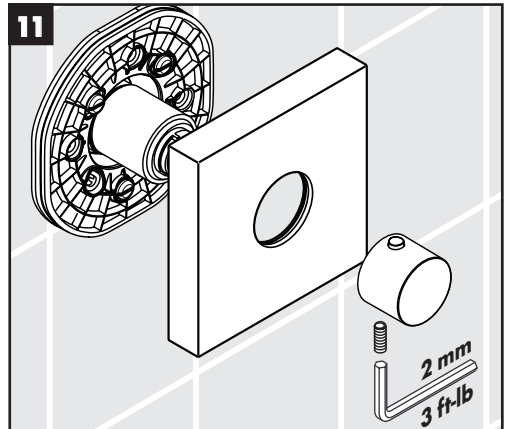

Set the high temperature limit stop.

Justify the handle.

Set the high temperature limit stop

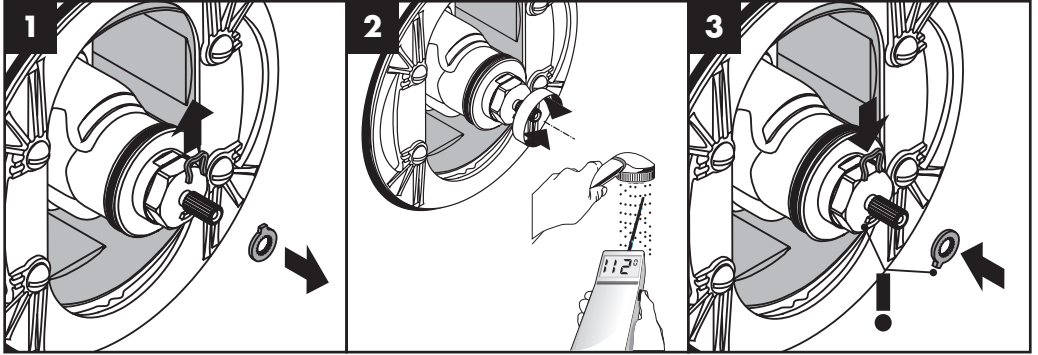

Remove the clip from the thermostatic mixer stem.

Remove the stop ring.

Turn the stem until the output water reaches the desired maximum high temperature*.

Install the stop ring so that the tooth is against the stop. It should not be possible to turn the stem further counter-clockwise.

*To prevent scalding, the maximum output temperature of the shower valve must be no higher than 120°. In Massachusetts, the maximum output temperature of the shower valve can be no higher than 112°F.

Justify the handle

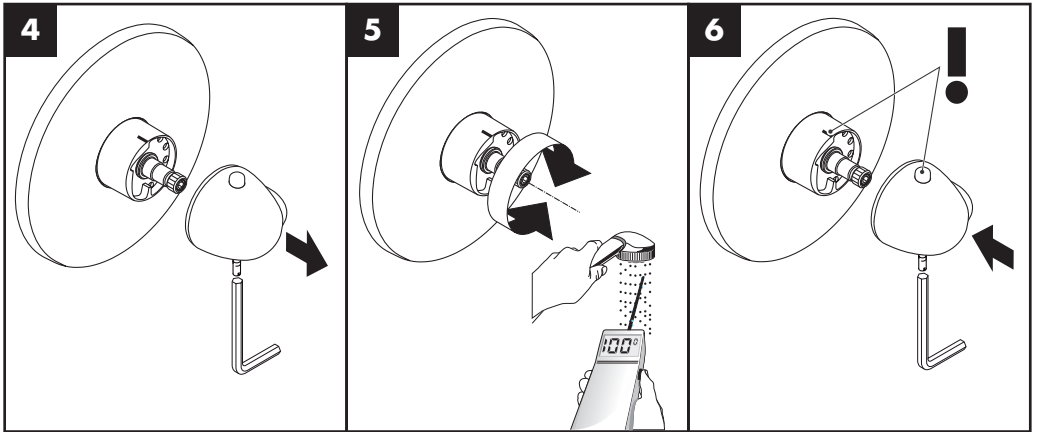

Remove the handle (if installed).

Turn the stem until the output water is 100°F.

Install the handle so that the safety stop override button is at the 12:00 position.

Tighten the handle screw.

Troubleshooting

Problem	Possible Cause	Solution
Insufficient water	Supply pressure insufficient	Adjust the pressure
	Filters on thermostatic mixing cartridge dirty	Clean the filters
	Handshower or showerhead filter gasket dirty	Clean the filter gasket
	Check valve filters dirty	Clean the filters
(New installation) Both hot and cold water are present, but won't mix	Supplies are reversed	Correct the plumbing
Hot water bleeds over into cold supply or vice-versa	Check valve(s) dirty or worn	Replace the check valve(s).
Regulation of the temperature is not possible	Thermostatic cartridge is dirty or worn	Replace the thermostatic cartridge
Safety stop override button cannot be pushed	Button is dirty	Clean the button
	Button is broken	Replace the button

Replacement Parts

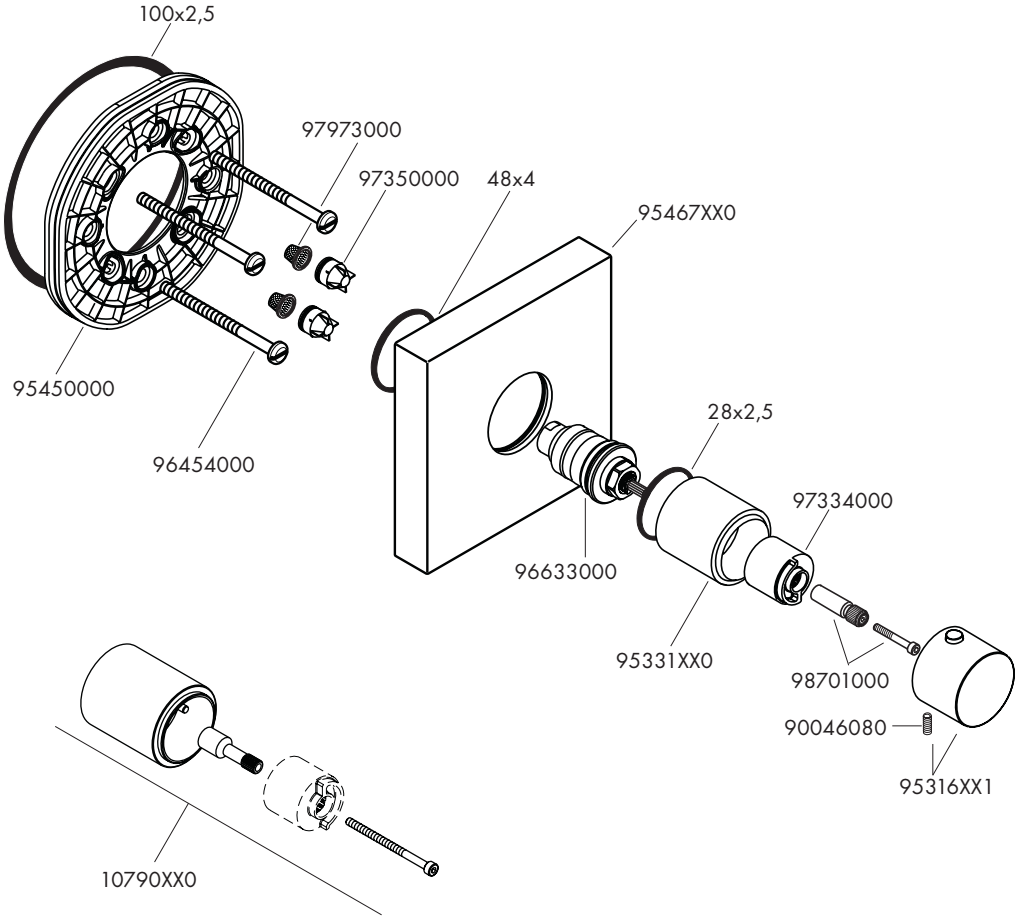

Cleaning Recommendation for Hansgrohe Products

Modern lavatory faucets, kitchen faucets, and showers consist of very different materials to comply with the needs of the market with regard to design and functionality. To avoid damage and returns, it is necessary to consider certain criteria when cleaning.

Cleaning Materials for Faucets and Showers

Acids are a necessary ingredient of cleaning materials for removing lime, however please pay attention to the following points when cleaning faucets and showers:

- Only use cleaning materials which are explicitly intended for this type of application.
- Never use cleaning materials which contain hydrochloric, formic, phosphoric, or acetic acid, as they cause considerable damage.
- Never mix one cleaning material with another.
- Never use cleaning materials or appliances with an abrasive effect, such as unsuitable cleaning powders, sponge pads, or micro fiber cloths.

Cleaning Instructions for Faucets and Showers

Please follow the cleaning material manufacturer's instructions. In addition, pay attention to the following points:

- Clean the faucets and showers as and when required
- Use the amount of cleaning product and the amount of time recommended by the manufacturer. Do not leave the cleaner on the fixture longer than necessary.
- Regular cleaning can prevent calcification.
- When using spray cleaners, spray first onto a soft cloth or sponge. Never spray directly onto the faucet as droplets can enter openings and gaps and cause damage.
- After cleaning, rinse thoroughly with clean water to remove any cleaner residue.

Important

Residues of liquid soaps, shampoos, and shower foams can also cause damage, so rinse with clean water after using.

Please note: if the surface is already damaged, the effect of cleaning materials will cause further damage.

Components with damaged surfaces must be replaced or injury could result.

Damage caused by improper treatment is not covered under the warranty.

Limited Lifetime Consumer Warranty

This product has been manufactured and tested to the highest quality standards by Hansgrohe, Inc. ("Hansgrohe"). This warranty is limited to Hansgrohe products which are purchased by a consumer in the United States after March 1, 1996, and installed in either the United States or Canada.

WHO IS COVERED BY THE WARRANTY

This warranty extends to the original consumer purchaser only. This warranty is non-transferable.

WHAT IS COVERED BY THE WARRANTY

This warranty covers only your Hansgrohe manufactured product. Hansgrohe warrants this product against defects in material or workmanship as follows: Hansgrohe will repair at no charge for parts only or, at its option, replace any product or part of the product that proves defective because of improper workmanship and/or material, under normal installation, use, service and maintenance. If Hansgrohe is unable to provide a replacement and repair is not practical or cannot be timely made, Hansgrohe may elect to refund the purchase price in exchange for the return of the product.

LENGTH OF WARRANTY

Replacement or repaired parts of products will be covered for the term of this warranty as stated in the following two sentences. If you are a consumer who purchased the product for use primarily for personal, family, or household purposes, this warranty extends for as long as you own the product and the home in which the product is originally installed. If you purchased the product for use primarily for any other purpose, including, without limitation, a commercial purpose, this warranty extends only (i) for 1 year, with respect to Hansgrohe and Commercial products, and (ii) for 5 years, with respect to AXOR products.

THIS WARRANTY DOES NOT COVER, AND HANSGROHE WILL NOT PAY FOR:

- A. Conditions, malfunctions or damage not resulting from defects in material or workmanship.
- B. Conditions, malfunctions or damage resulting from (1) normal wear and tear, improper installation, improper maintenance, misuse, abuse, negligence, accident or alteration, or (2) the use of abrasive or caustic cleaning agents or "no-rinse" cleaning products, or the use of the product in any manner contrary to the product instructions. (3) Conditions in the home such as excessive water pressure or corrosion.
- C. Labor or other expenses for the disconnection, deinstallation, or return of the product for warranty service, or for installation or reinstallation of the product (including but not limited to proper packaging and shipping costs), or for installation or reinstallation of the product.
- D. Accessories, connected materials and products, or related products not manufactured by Hansgrohe.

TO OBTAIN WARRANTY PARTS OR INFORMATION

Contact your Hansgrohe retailer, or contact Technical Service at:

Hansgrohe Inc.
1492 Bluegrass Lakes Parkway
Alpharetta GA 30004
Toll-free (800) 334-0455.

In requesting warranty service, you will need to provide

1. The sales receipt or other evidence of the date and place of purchase.
2. A description of the problem.
3. Delivery of the product or the defective part, postage prepaid and carefully packed and insured, to Hansgrohe Inc. 1492 Bluegrass Lakes Parkway, Alpharetta, Georgia 30004, Attention: Technical Service, if required by Hansgrohe.

When warranty service is completed, any repaired or replacement product or part will be returned to you postage prepaid.

EXCLUSIONS AND LIMITATIONS

REPAIR OR REPLACEMENT (OR, IN LIMITED CIRCUMSTANCES, REFUND OF THE PURCHASE PRICE) AS PROVIDED UNDER THIS WARRANTY IS THE EXCLUSIVE REMEDY OF THE PURCHASER. HANSGROHE NEITHER ASSUMES NOR AUTHORIZES ANY PERSON TO CREATE FOR IT ANY OBLIGATION OR LIABILITY IN CONNECTION WITH THIS PRODUCT.

HANSGROHE SHALL NOT BE LIABLE TO PURCHASER OR ANY PERSON FOR ANY INCIDENTAL, SPECIAL, OR CONSEQUENTIAL DAMAGES, ARISING OUT OF BREACH OF THIS WARRANTY OR ANY IMPLIED WARRANTY (INCLUDING MERCHANTABILITY).

Some States do not allow the exclusion or limitation of incidental or consequential damages, so the above limitation or exclusion may not apply to you. This warranty gives you specific legal rights, and you may have other rights which vary from State to State. You may be required by law to give us a reasonable opportunity to correct or cure any failure to comply before you can bring any action in court against us under the Magnuson-Moss Warranty Act.

PRODUCT INSTRUCTIONS AND QUESTIONS

Upon purchase or prior to installation, please carefully inspect your Hansgrohe product for any damage or visible defect. Prior to installing, always carefully study the enclosed instructions on the proper installation and the care and maintenance of the product. If you have questions at any time about the use, installation, or performance of your Hansgrohe product, or this warranty, please call or write to us or call us toll-free at 800 334 0455.

hansgrohe

Hansgrohe, Inc. • 1490 Bluegrass Lakes Parkway • Alpharetta, GA 30004
Tel. 770-360-9880 • Fax 770-360-9887

www.hansgrohe-usa.com