

# Installation Instructions / Warranty

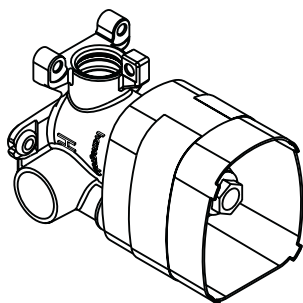

**Starck**  
10754181

**AXOR**<sup>®</sup>  
hansgrohe

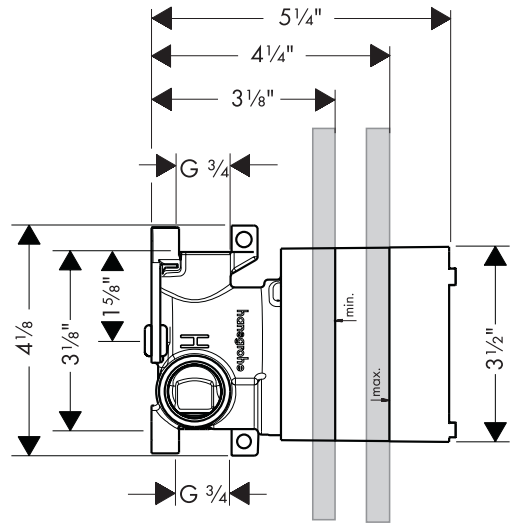
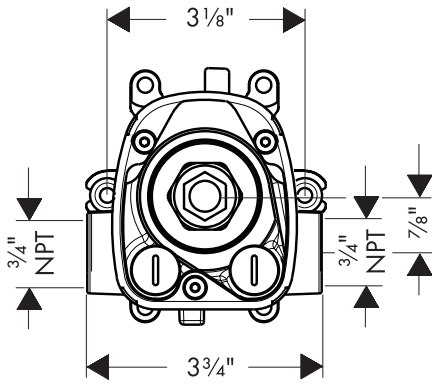

## Technical Information

Recommended water pressure	15 - 75 psi
Max. water pressure	145 psi
Recommended hot water temp.	120°-140° F*
Max. hot water temp	176° F*
Flow rate	14.5 gpm

\*Please know and follow all applicable local plumbing codes when setting the temperature on the water heater.

## Installation Considerations

- For best results, Hansgrohe recommends that this unit be installed by a licensed, professional plumber.
- Please read over these instructions thoroughly before beginning installation. Make sure that you have all tools and supplies needed to complete the installation.
- This rough is for use with Axor Starck thermostatic mixer trim 10755XX1.
- The thermostatic cartridge is included with the trim kit.
- The thermostatic cartridge incorporates a high temperature limit stop that can be reset to comply with local plumbing codes.
- To prevent scalding, the maximum output temperature of the shower valve must be no higher than 120°. In Massachusetts, the maximum output temperature of the shower valve can be no higher than 112°F.
- The valve includes check valves that should be inspected at least once per year.
- Keep this booklet and the receipt (or other proof of date and place of purchase) for this product in a safe place. The receipt is required should it be necessary to request warranty parts.

# Installation Suggestions

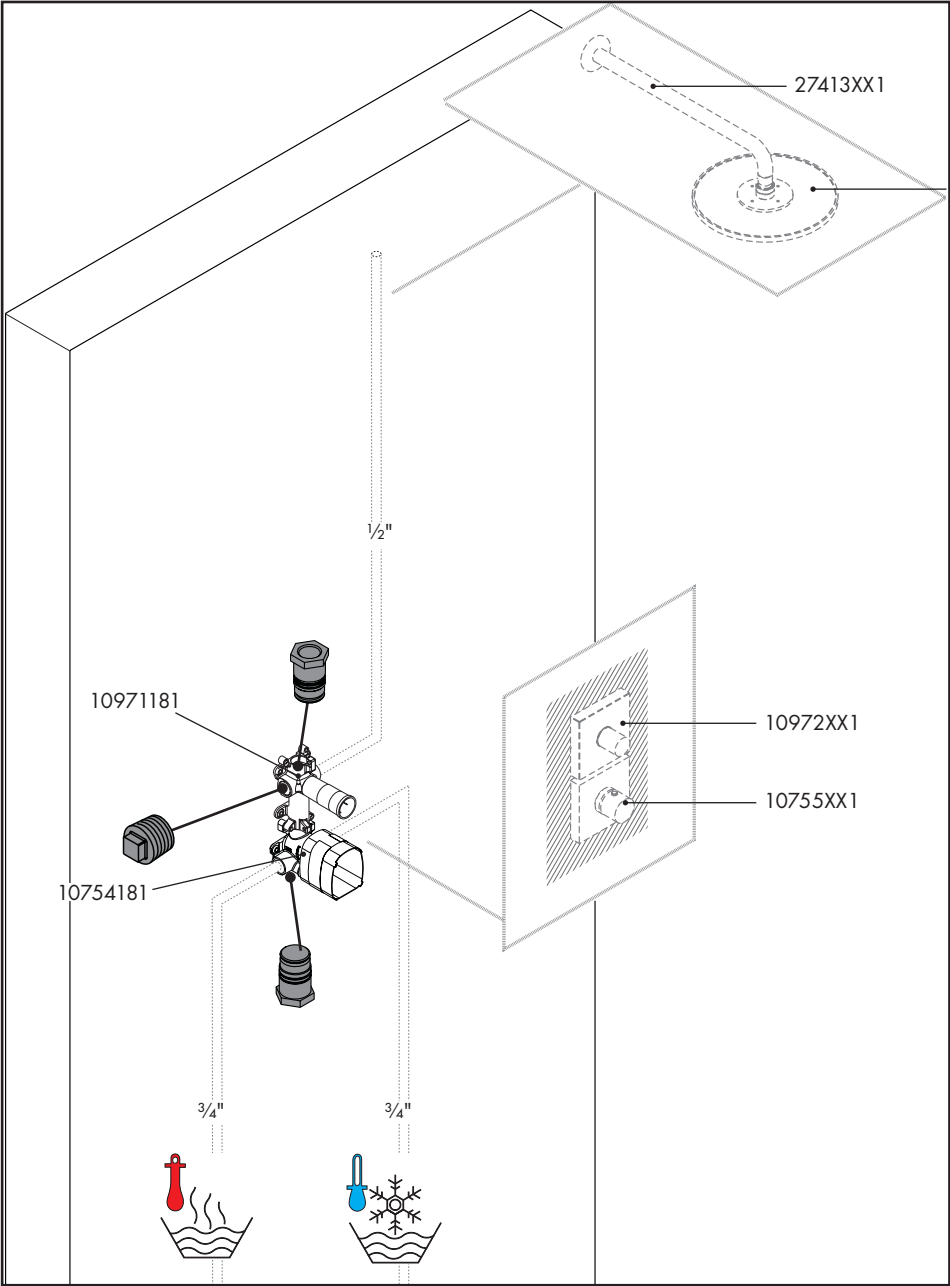

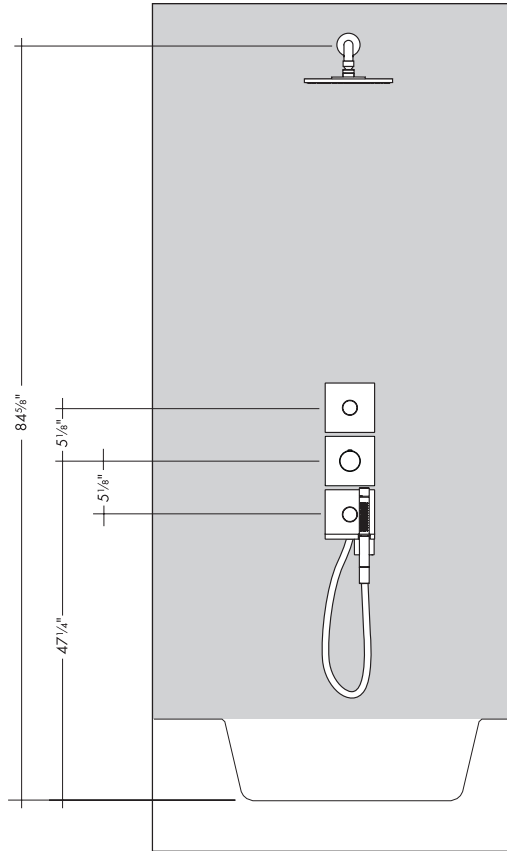
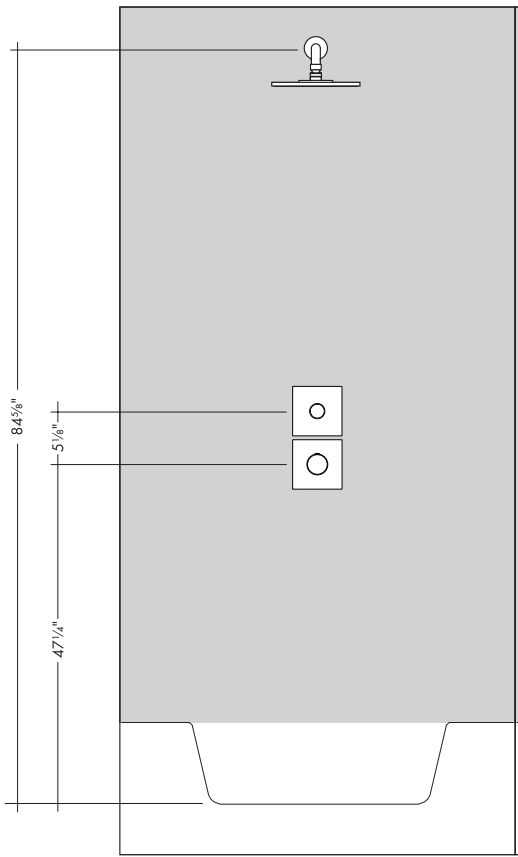

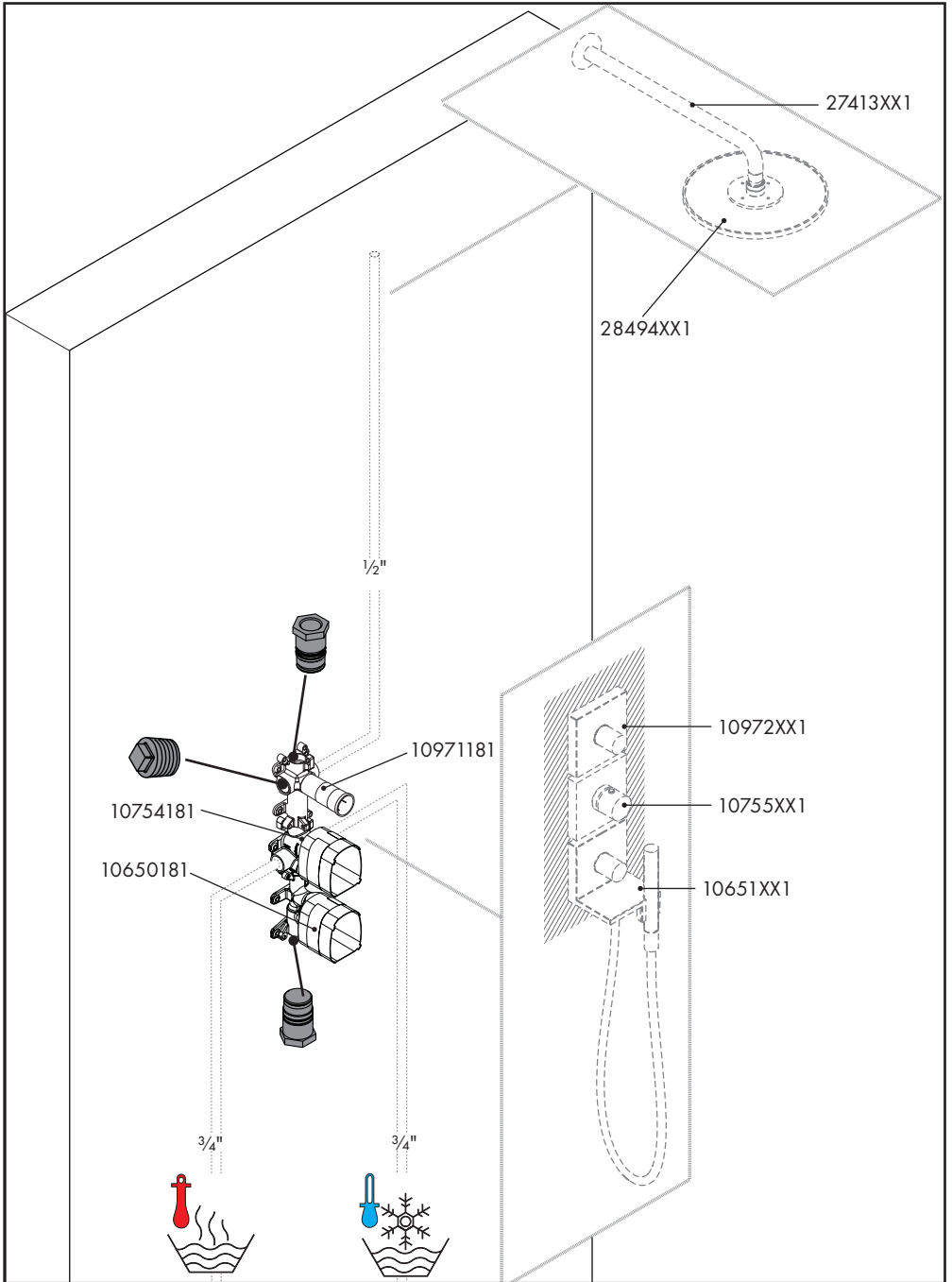

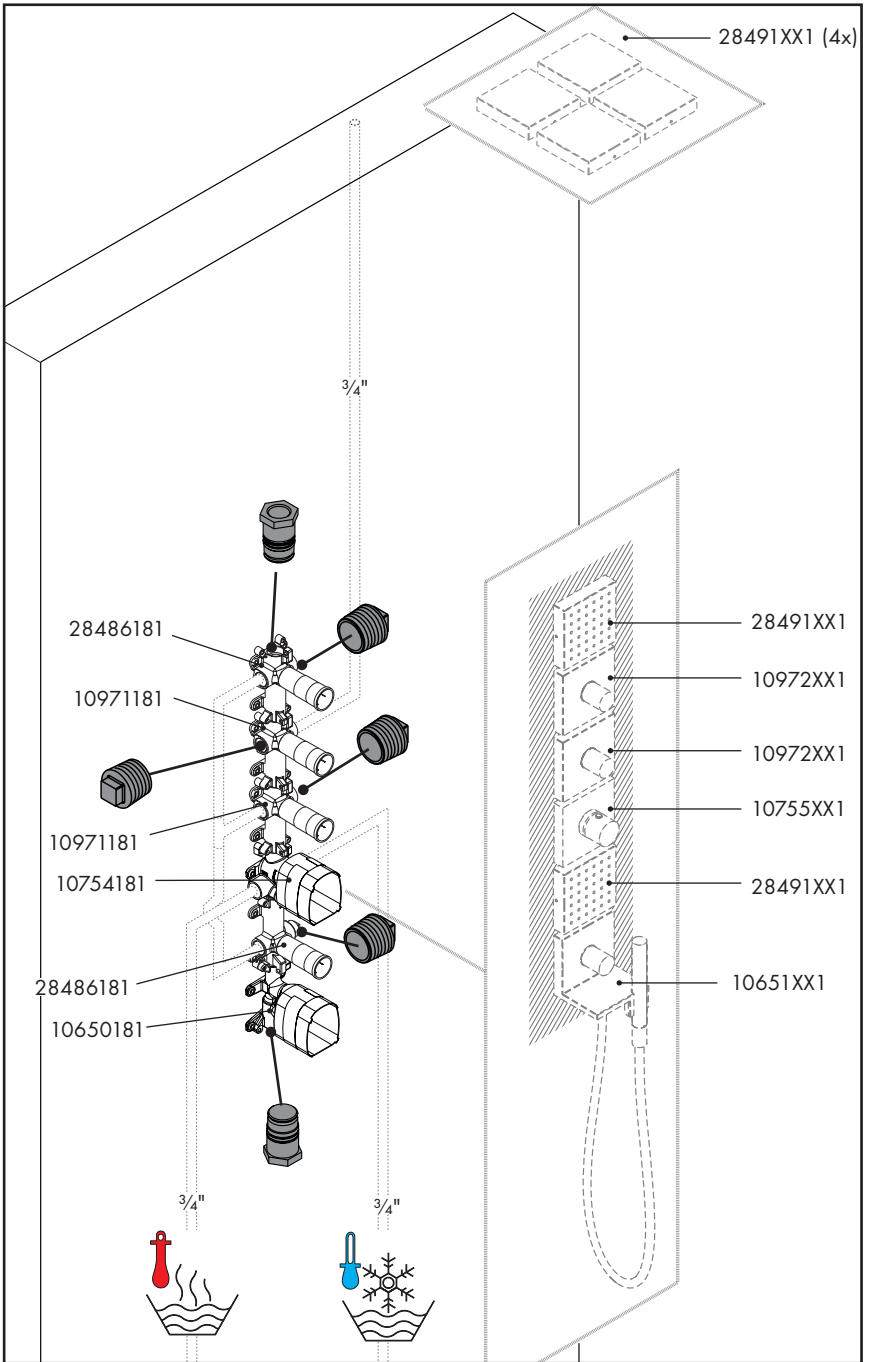

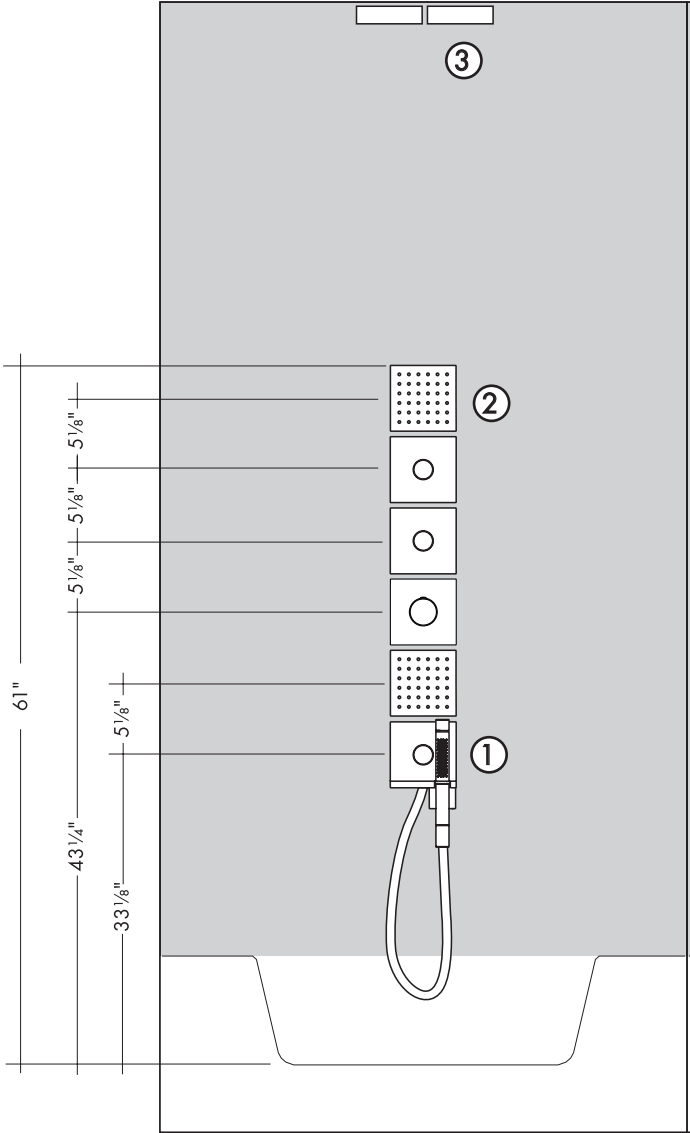

Showerheaven 720 x 720  
10625XX1

3/4"

3/4"

3/4"

10971181

10971181

10971181

10974181

10972XX1

10972XX1

10972XX1

10755XX1

3/4"



3/4"





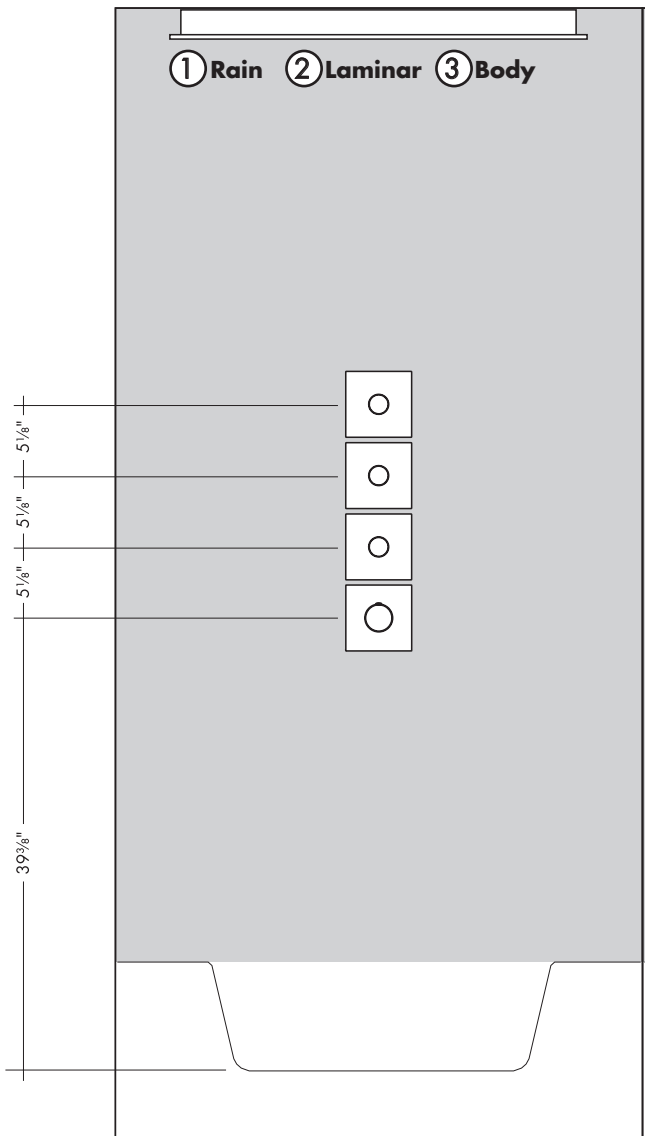

Showerheaven 720 x 720  
10625XX1

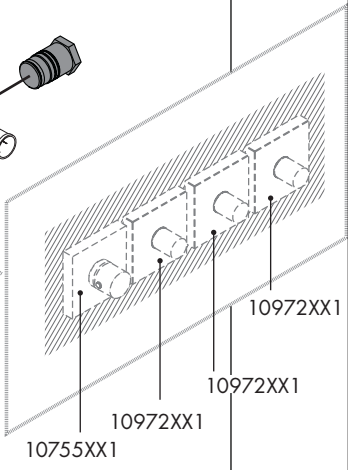
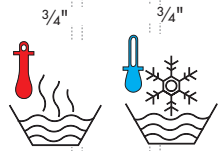
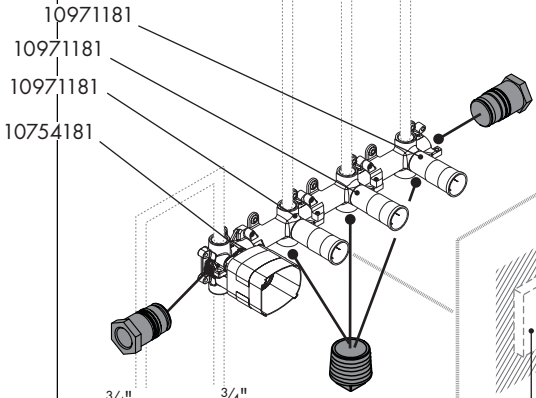

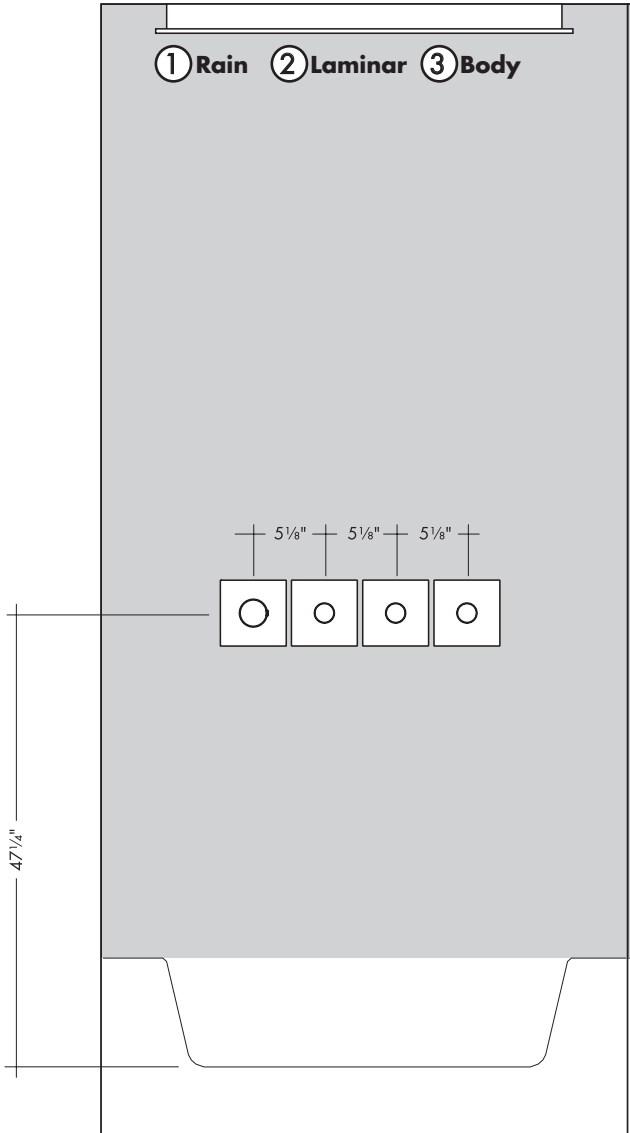

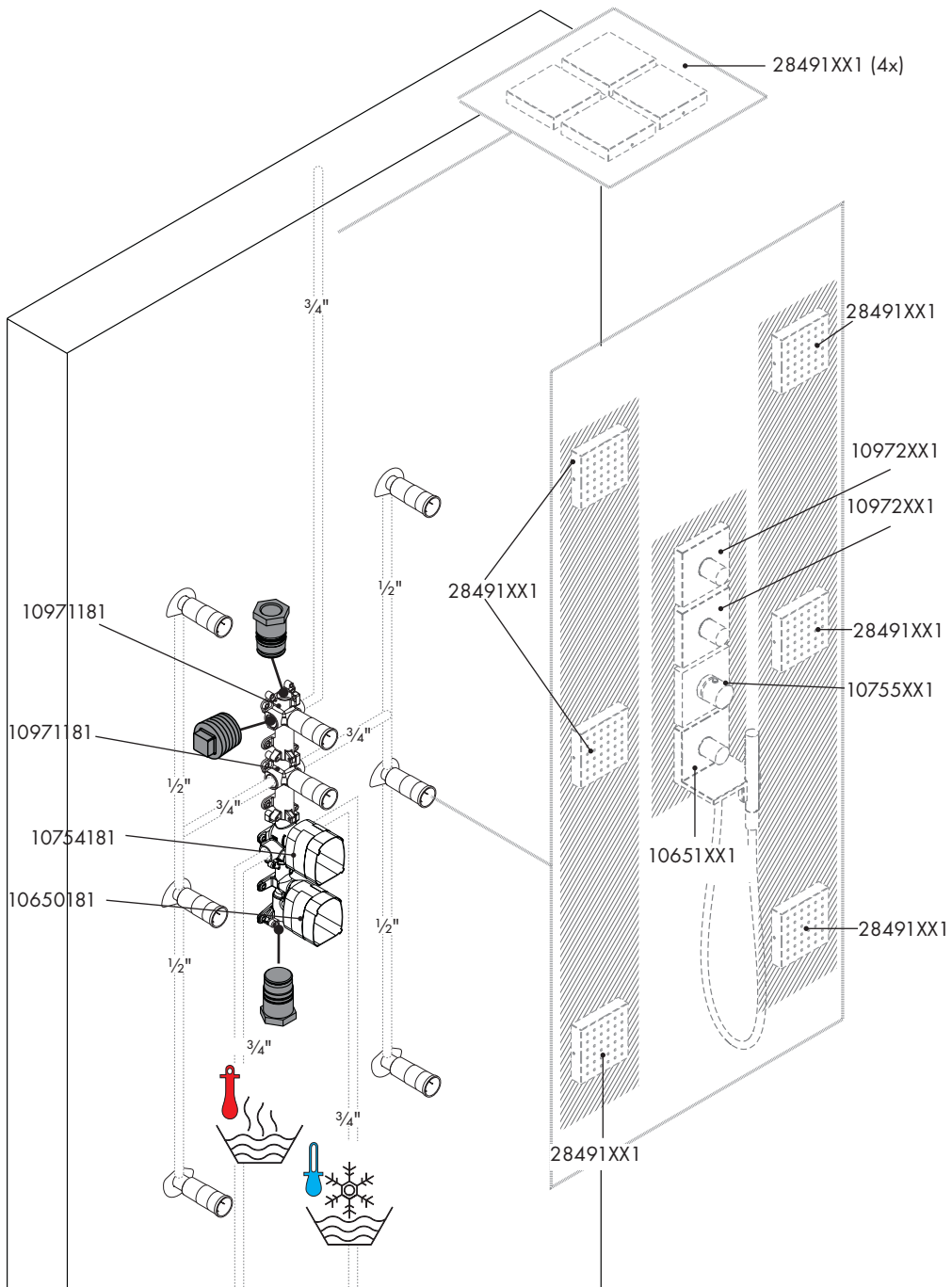

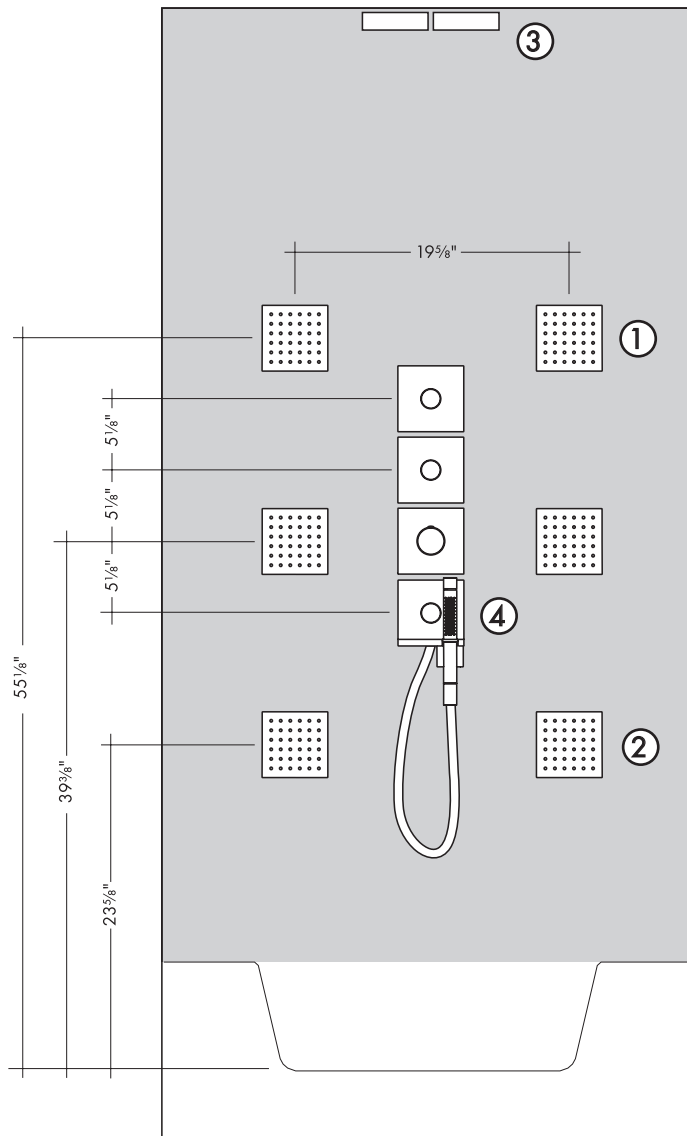

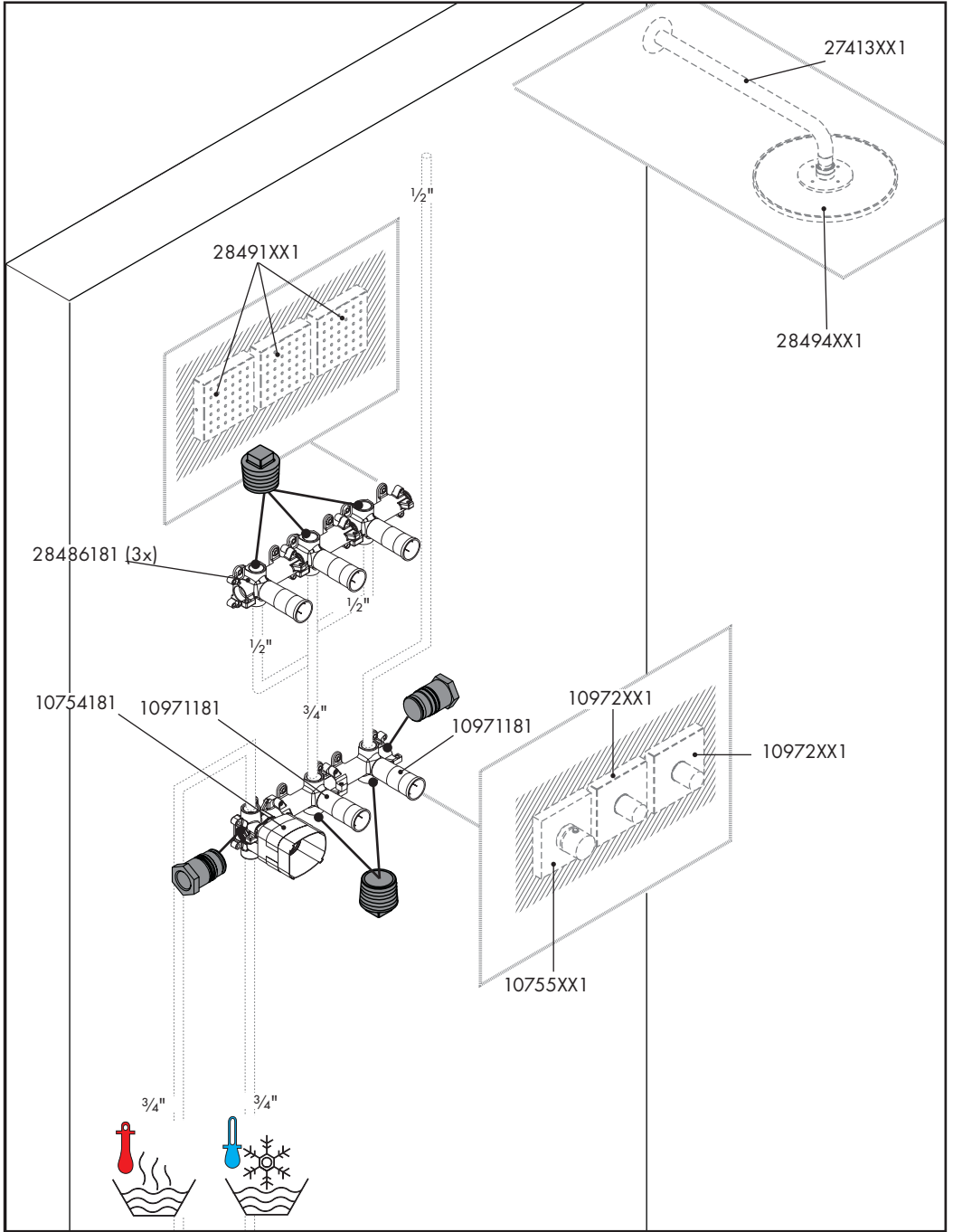

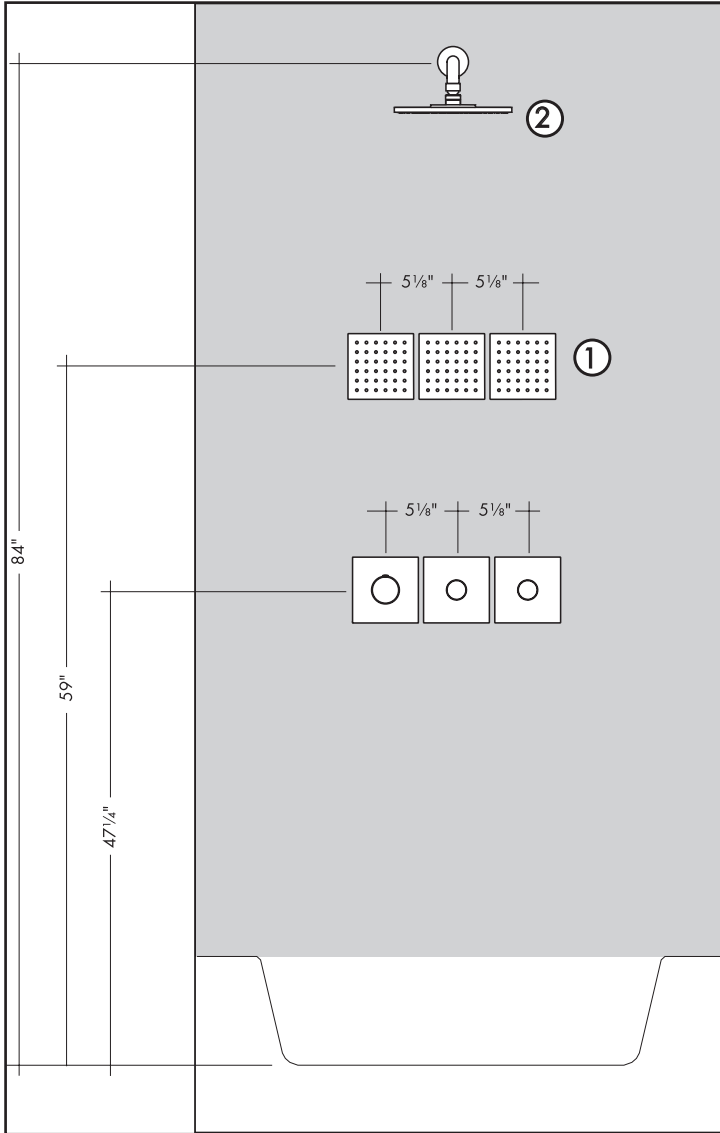



## Installation

The 10754181 rough includes two model 95335001 plugs.

Use the plug to seal one of the end ports if no other valve is connected to it.

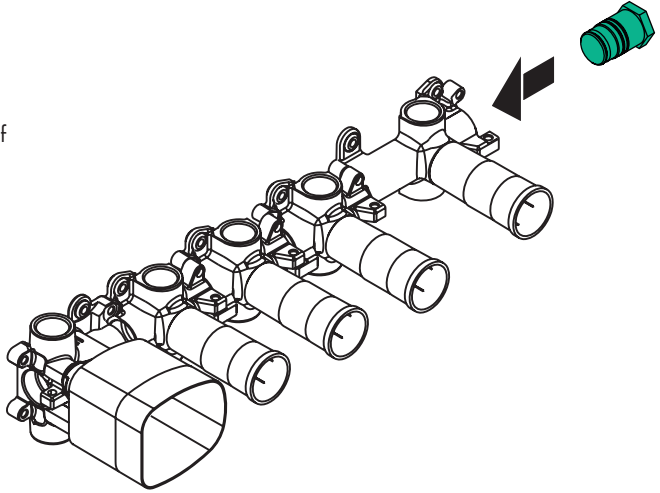

Cut the plug as shown to create an adapter, allowing 1/2" NPT pipe to be connected to the end of the valve.

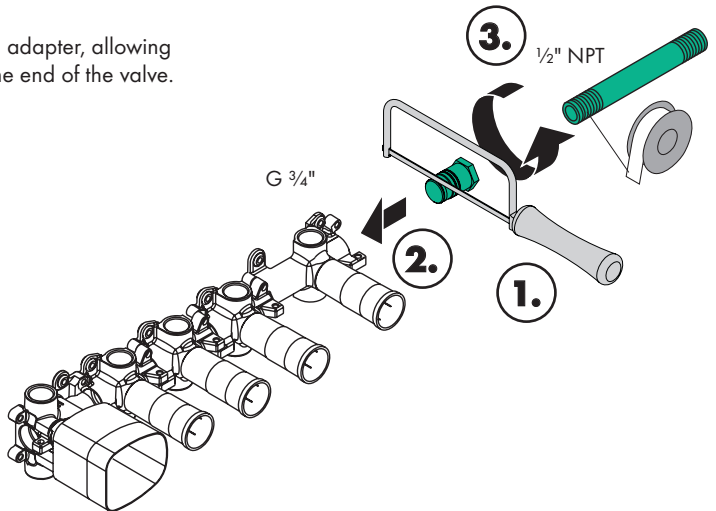



Remove the plugs from the rough.

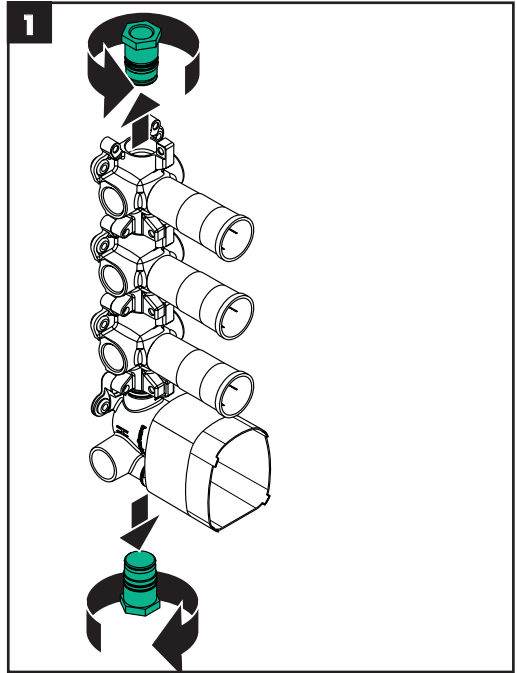

To connect another valve, lubricate the o-rings on the valve (1).

Push the valves together (2).

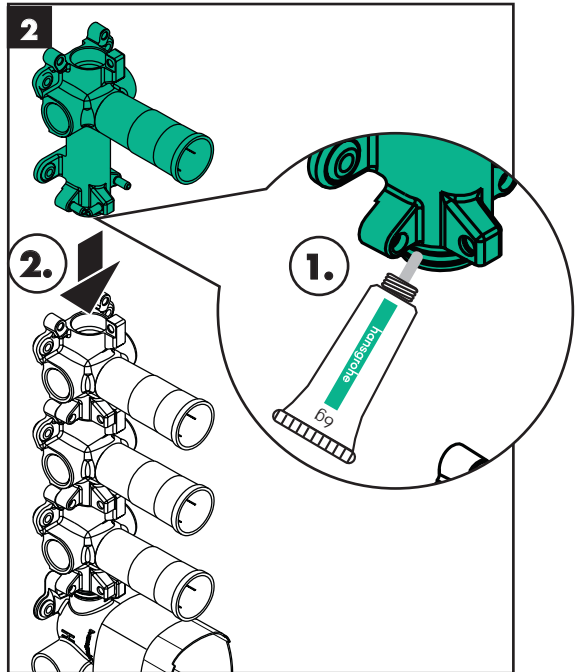

Connect the valves using the dowel pins.

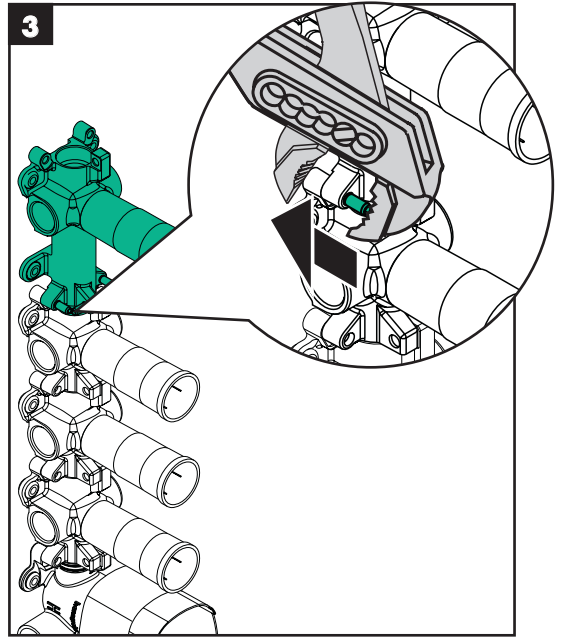

Make sure that the connected valves are level.

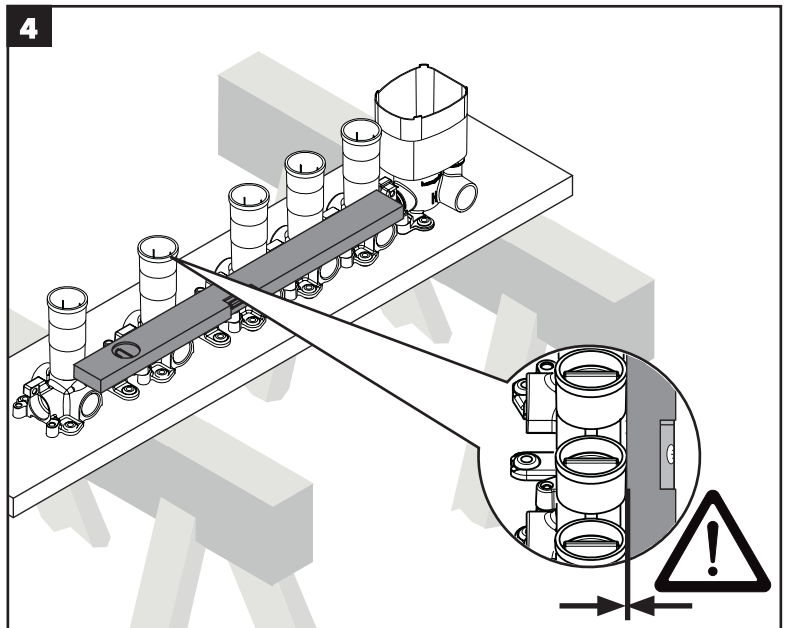

The inlets on the 10754181 rough are 3/4" NPT.

Connect the hot and cold supplies to the correct inlets.

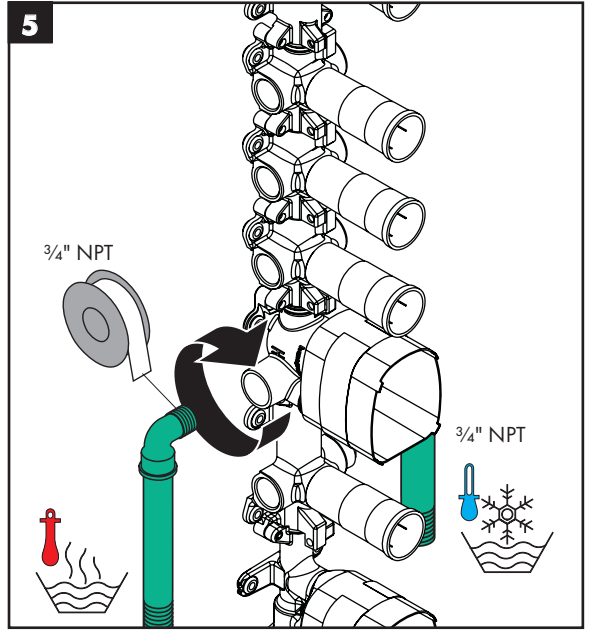

The outlets on the 10971181 volume control rough and the inlets on the 28486181 bodyspray rough are 3/4" NPT

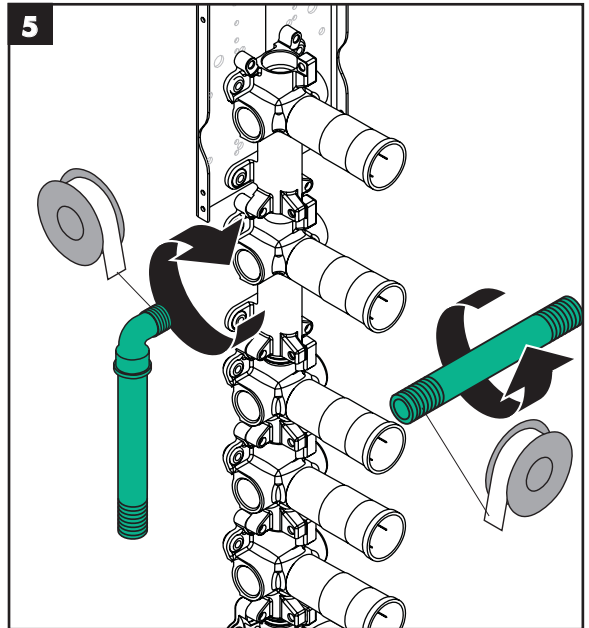

Install the noise reducers (1).

Make sure that the joined valves are level (2).

Secure the valves to the header.

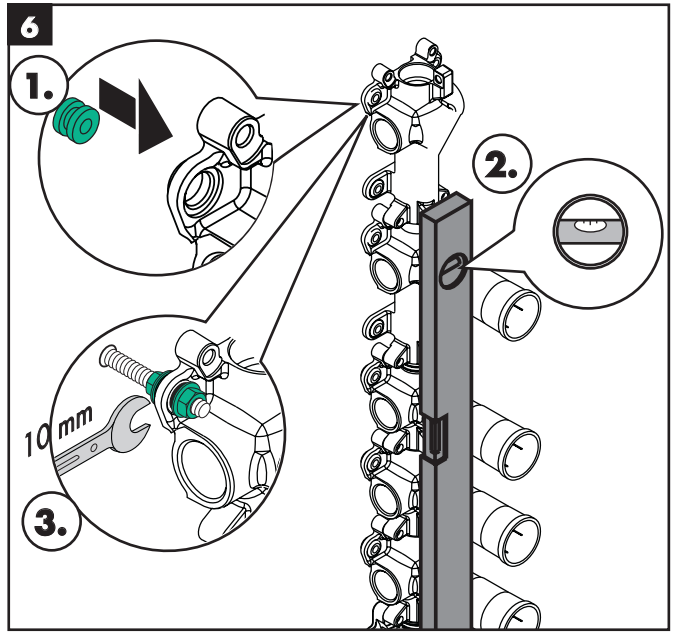

Install the valve so that the outside surface of the finished wall falls between the "minimum" and "maximum" markings on the plaster shield.

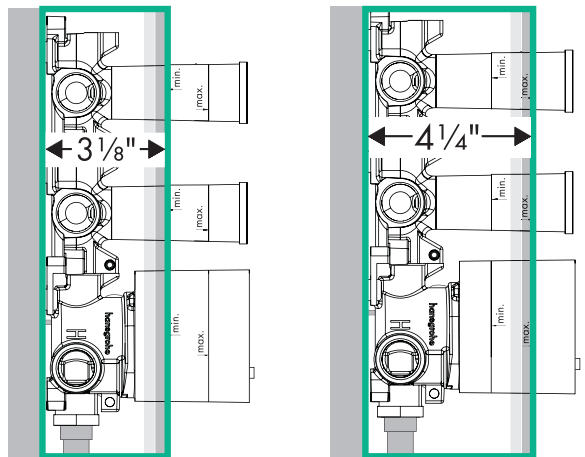

Flush the valves:

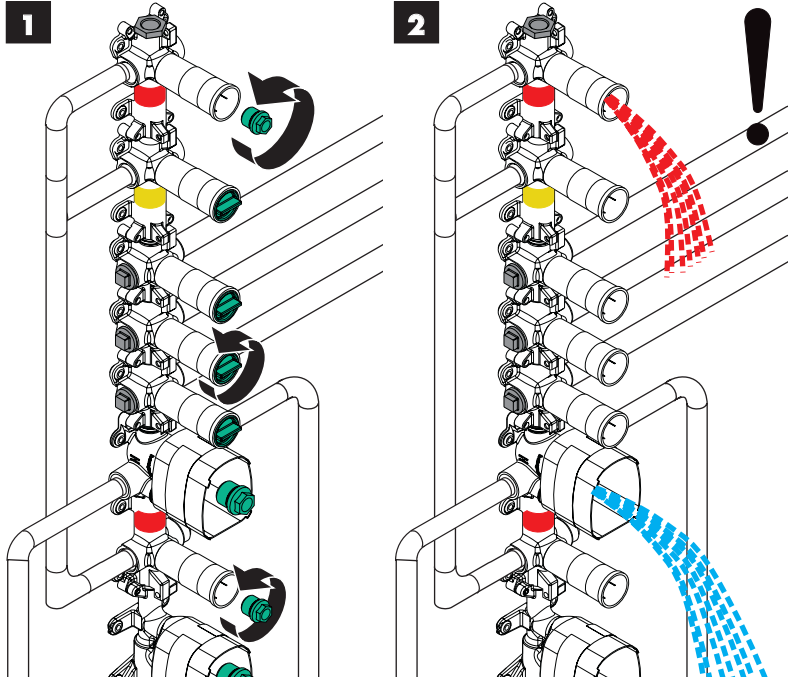

Install the greenboard or other backing board over the valves.

Seal the greenboard around the valves using water-proof sealant.

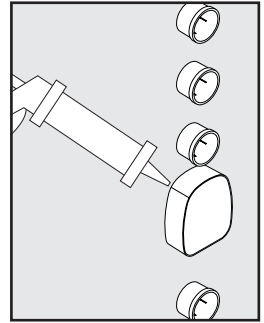

Spread adhesive (not included) on the wall around the valves.

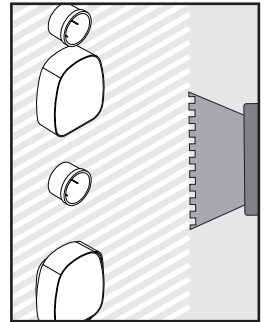

Install the gasket(s). Cut the gaskets if necessary.

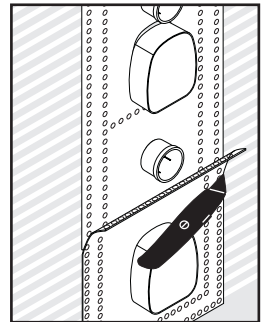

Install the tile or other finished wall surface over the gasket.

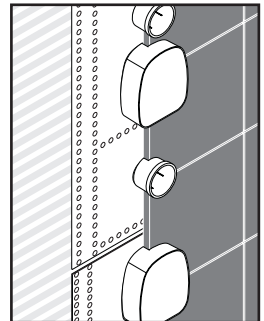

## Replacement Parts

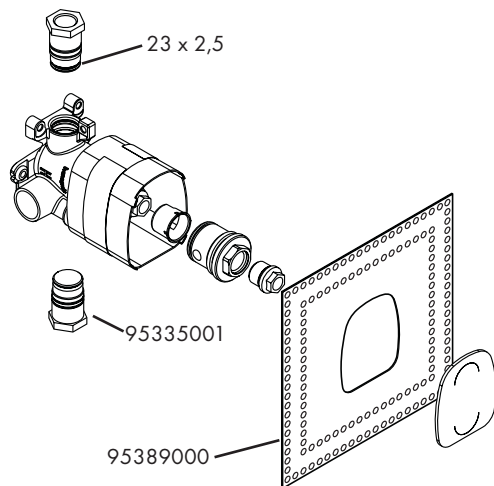

## Limited Lifetime Consumer Warranty

This product has been manufactured and tested to the highest quality standards by Hansgrohe, Inc. ("Hansgrohe"). This warranty is limited to Hansgrohe products which are purchased by a consumer in the United States after March 1, 1996, and installed in either the United States or Canada.

### WHO IS COVERED BY THE WARRANTY

This warranty extends to the original consumer purchaser only. This warranty is non-transferable.

### WHAT IS COVERED BY THE WARRANTY

This warranty covers only your Hansgrohe manufactured product. Hansgrohe warrants this product against defects in material or workmanship as follows: Hansgrohe will repair at no charge for parts only or, at its option, replace any product or part of the product that proves defective because of improper workmanship and/or material, under normal installation, use, service and maintenance. If Hansgrohe is unable to provide a replacement and repair is not practical or cannot be timely made, Hansgrohe may elect to refund the purchase price in exchange for the return of the product.

### LENGTH OF WARRANTY

Replacement or repaired parts of products will be covered for the term of this warranty as stated in the following two sentences. If you are a consumer who purchased the product for use primarily for personal, family, or household purposes, this warranty extends for as long as you own the product and the home in which the product is originally installed. If you purchased the product for use primarily for any other purpose, including, without limitation, a commercial purpose, this warranty extends only (i) for 1 year, with respect to Hansgrohe and Commercial products, and (ii) for 5 years, with respect to AXOR products.

### THIS WARRANTY DOES NOT COVER, AND HANSGROHE WILL NOT PAY FOR:

- A. Conditions, malfunctions or damage not resulting from defects in material or workmanship.
- B. Conditions, malfunctions or damage resulting from (1) normal wear and tear, improper installation, improper maintenance, misuse, abuse, negligence, accident or alteration, or (2) the use of abrasive or caustic cleaning agents or "no-rinse" cleaning products, or the use of the product in any manner contrary to the product instructions. (3) Conditions in the home such as excessive water pressure or corrosion.
- C. Labor or other expenses for the disconnection, deinstallation, or return of the product for warranty service, or for installation or reinstallation of the product (including but not limited to proper packaging and shipping costs), or for installation or reinstallation of the product.
- D. Accessories, connected materials and products, or related products not manufactured by Hansgrohe.

### TO OBTAIN WARRANTY PARTS OR INFORMATION

Contact your Hansgrohe retailer, or contact Technical Service at:

Hansgrohe Inc.  
1492 Bluegrass Lakes Parkway  
Alpharetta GA 30004  
Toll-free (800) 334-0455.

In requesting warranty service, you will need to provide

1. The sales receipt or other evidence of the date and place of purchase.
2. A description of the problem.
3. Delivery of the product or the defective part, postage prepaid and carefully packed and insured, to Hansgrohe Inc. 1492 Bluegrass Lakes Parkway, Alpharetta, Georgia 30004, Attention: Technical Service, if required by Hansgrohe.

When warranty service is completed, any repaired or replacement product or part will be returned to you postage prepaid.

### EXCLUSIONS AND LIMITATIONS

REPAIR OR REPLACEMENT (OR, IN LIMITED CIRCUMSTANCES, REFUND OF THE PURCHASE PRICE) AS PROVIDED UNDER THIS WARRANTY IS THE EXCLUSIVE REMEDY OF THE PURCHASER. HANSGROHE NEITHER ASSUMES NOR AUTHORIZES ANY PERSON TO CREATE FOR IT ANY OBLIGATION OR LIABILITY IN CONNECTION WITH THIS PRODUCT.

HANSGROHE SHALL NOT BE LIABLE TO PURCHASER OR ANY PERSON FOR ANY INCIDENTAL, SPECIAL, OR CONSEQUENTIAL DAMAGES, ARISING OUT OF BREACH OF THIS WARRANTY OR ANY IMPLIED WARRANTY (INCLUDING MERCHANTABILITY).



Some States do not allow the exclusion or limitation of incidental or consequential damages, so the above limitation or exclusion may not apply to you. This warranty gives you specific legal rights, and you may have other rights which vary from State to State. You may be required by law to give us a reasonable opportunity to correct or cure any failure to comply before you can bring any action in court against us under the Magnuson-Moss Warranty Act.

#### PRODUCT INSTRUCTIONS AND QUESTIONS

Upon purchase or prior to installation, please carefully inspect your Hansgrohe product for any damage or visible defect. Prior to installing, always carefully study the enclosed instructions on the proper installation and the care and maintenance of the product. If you have questions at any time about the use, installation, or performance of your Hansgrohe product, or this warranty, please call or write to us or call us toll-free at 800 334 0455.

**hansgrohe**

Hansgrohe, Inc. • 1490 Bluegrass Lakes Parkway • Alpharetta, GA 30004  
Tel. 770-360-9880 • Fax 770-360-9887

**[www.hansgrohe-usa.com](http://www.hansgrohe-usa.com)**