

or Residential and Commercial Applications

Job Name		Engineer / Architect	
Job Location		Wholesaler	
Submittal Date		Contractor	

O3300/ O3301/ S3301 Multi-Turn Angle Stop - Female Iron Pipe x Slip-Joint (Optional Loose Key)

Use: For use in potable water distribution systems. Not intended for recirculating water systems that produce continuous use temperatures above 115° F. For those applications, use BrassCraft KT series ball stops

Design Features:

- **Machined one-piece brass body** provides strength, durability and long-lasting performance
- **Oval knurled handle** provides a secure grip and smooth on/off operation
- **Compliant Multi-turn Stops** available for California and Vermont “low-lead” requirements

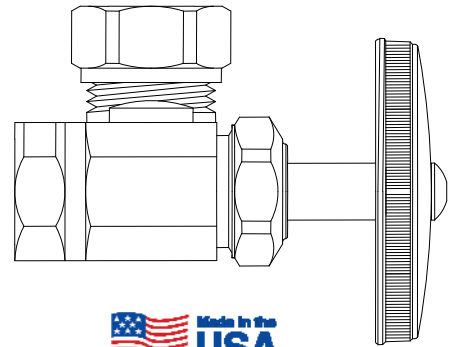

Operating Specifications:

Temperature: 40° - 140° F
Pressure: 125 psi maximum

Standard

MATERIAL SPECIFICATIONS	
Valve Body	C36000 brass
Stem	POM or C36000 brass*
Bib & Packing Washers	Nitrile or EPDM rubber
Packing Nut	C36000 brass
Handle	Plated metal, chrome-plated ABS or Lexan
Handle Screw	Zinc-plated Steel
Slip-Joint Washer	NBR rubber
Slip-Joint Nut	C36000 brass
Friction Rings	C27200 brass
Optional Loose Key	
Loose Key Stem	C36000 brass
Loose Key	Zinc die cast

Compliant

MATERIAL SPECIFICATIONS	
Valve Body	Compliant brass
Stem	POM or Compliant brass*
Bib & Packing Washers	Nitrile or EPDM rubber
Packing Nut	C36000 brass
Handle	Plated metal, chrome-plated ABS or Lexan
Handle Screw	Zinc-plated Steel
Slip-Joint Washer	NBR rubber
Slip-Joint Nut	C36000 brass
Friction Rings	C27200 brass
Optional Loose Key	
Loose Key Stem	Compliant brass
Loose Key	Zinc die cast

*Where specified

Standard Part Listing:

- O3300 C 3/8" F.I.P. x 7/16" & 1/2" Slip-Joint, chrome plated
- O3301 C 1/2" F.I.P. x 7/16" & 1/2" Slip-Joint, chrome plated
- O3301 C1 1/2" F.I.P. x 7/16" & 1/2" Slip-Joint, chrome plated, window tray
- O3301 R 1/2" F.I.P. x 7/16" & 1/2" Slip-Joint, rough brass
- O3301 R1 1/2" F.I.P. x 7/16" & 1/2" Slip-Joint, rough brass, window tray

This specification and all information contained herein is the confidential and exclusive property of BrassCraft Manufacturing, and shall not be disclosed to others without the written consent of BrassCraft. This specification must be returned to BrassCraft if requested.



O3301/ S3301 Multi-Turn Angle Stop - Female Iron Pipe x Slip-Joint Optional Loose Key

Standard Part Listing (con't):

- O3301N C 1/2" F.I.P. x 7/16" & 1/2" Slip-Joint, less outlet nut, chrome plated
- O3301N C100T 1/2" F.I.P. x 7/16" & 1/2" Slip-Joint, less outlet nut, chrome plated, bulk
- O3301Z C 1/2" F.I.P. x 7/16" & 1/2" Slip-Joint, brass stem, chrome plated
- S3301 C 1/2" F.I.P. x 7/16" & 1/2" Slip-Joint with loose key, chrome plated

Compliant Part Listing:

- O3301X C 1/2" F.I.P. x 7/16" & 1/2" Slip-Joint, chrome plated
- O3301X C1 1/2" F.I.P. x 7/16" & 1/2" Slip-Joint, chrome plated, window tray
- O3301X R 1/2" F.I.P. x 7/16" & 1/2" Slip-Joint, rough brass
- O3301NX C 1/2" F.I.P. x 7/16" & 1/2" Slip-Joint, less outlet nut, chrome plated
- O3301NX C100T 1/2" F.I.P. x 7/16" & 1/2" Slip-Joint, less outlet nut, chrome plated, bulk
- O3301ZX C 1/2" F.I.P. x 7/16" & 1/2" Slip-Joint, brass stem, chrome plated
- S3301X C 1/2" F.I.P. x 7/16" & 1/2" Slip-Joint with loose key, chrome plated

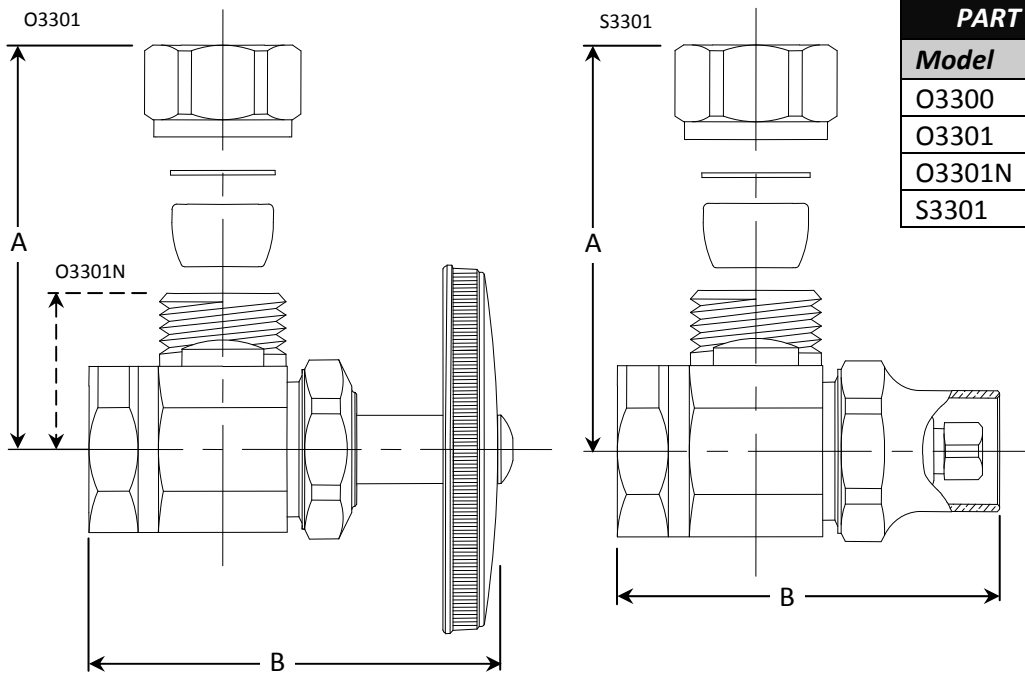

PART DIMENSIONS (Inches)		
Model	DIM. A	DIM. B
O3300	1.19	2.62
O3301	1.19	2.62
O3301N	.85	2.62
S3301	1.19	2.32

Listings & Certifications:

- IAPMO listed to ASME A112.18.1-05 / CSA B125.1-05 (File # 0645)
- CSA listed to ASME A112.18.1-05 / CSA B125.1-05 (File # 204593)
- Complaint product CSA approved to California Health & Safety Code 116875 and Vermont Bill S.152 (Project # 2174785)



This specification and all information contained herein is the confidential and exclusive property of BrassCraft Manufacturing, and shall not be disclosed to others without the written consent of BrassCraft. This specification must be returned to BrassCraft if requested.

BrassCraft[®]