

Class 200 Bronze Gate Valves

Block pattern • union bonnet • rising stem • alloy solid wedge • integral seat

200 PSI/13.8 bar saturated steam to 391° F/201° C
400 PSI/27.6 bar non-shock cold working pressure

CONFORMS TO MSS SP-80

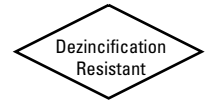

MATERIAL LIST

PART	SPECIFICATION
1. Handwheel Nut	300 Series Stainless Steel
2. Identification Plate	Aluminum
3. Handwheel	Malleable Iron ASTM A 47
4. Stem	Silicon Bronze ASTM B 371 Alloy C69400/C69430 or ASTM B 99 Alloy C65100
5. Packing Nut	Bronze ASTM B 62 or ASTM B584 Alloy C84400 or Brass ASTM B 16
6. Packing Gland	Bronze ASTM B 62 or ASTM B584 Alloy C84400 or Brass ASTM B16
7. Packing	Aramid Fibers with Graphite
8. Bonnet	Bronze ASTM B 61
9. Union Nut	Bronze ASTM B 61
10. Body	Bronze ASTM B 61
11. Wedge	ASTM B584 Alloy C97600



T-154-A
Threaded

DIMENSIONS—WEIGHTS—QUANTITIES

Size	Dimensions				Weight		Master Ctn. Qty.	
	A		B		Lbs.	Kg.		
In.	mm.	In.	mm.	In.	mm.			
¼	8	1.88	48	4.81	122	1.15	0.52	50
⅜	10	2.06	52	4.81	122	1.14	0.52	50
½	15	2.31	59	5.38	137	1.49	0.68	40
¾	20	2.44	62	6.31	160	2.23	1.01	30
1	25	2.88	73	7.56	192	3.37	1.53	20
1¼	32	3.13	83	8.88	226	4.76	2.16	10
1½	40	3.38	86	10.25	260	6.32	2.87	10
2	50	3.88	99	12.50	318	10.96	4.97	6

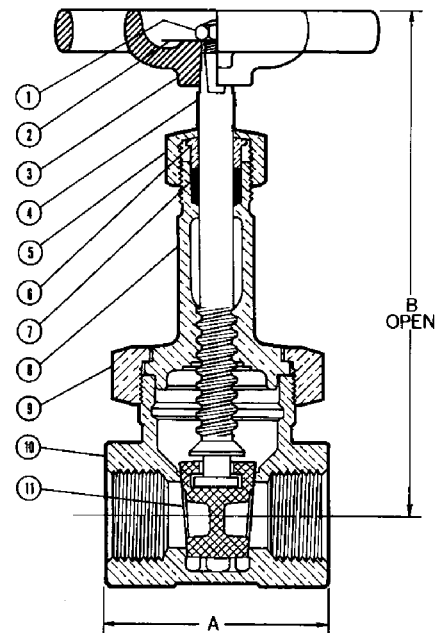

T-154-A
NPT x NPT
with Integral Seats

FREEZING WEATHER PRECAUTION: Subsequent to testing a piping system, valves should be left in an open position to allow complete drainage.

◆ For detailed Operating Pressure, refer to Pressure Temperature Chart on page 114.

Visit our website for the most current information.