



SERVICE PARTS LIST

BULLETIN NO.
54-06-2735

SPECIFY CATALOG NO. AND SERIAL NO. WHEN ORDERING PARTS		REVISED BULLETIN	DATE
CORDLESS 18 VOLT LED WORKLIGHT			Mar. 2012
CATALOG NO. 2735-20	STARTING SERIAL NO.	C12A	
		WIRING INSTRUCTION	

EXAMPLE:
Component Parts (Small #) Are Included When Ordering The Assembly (Large #).

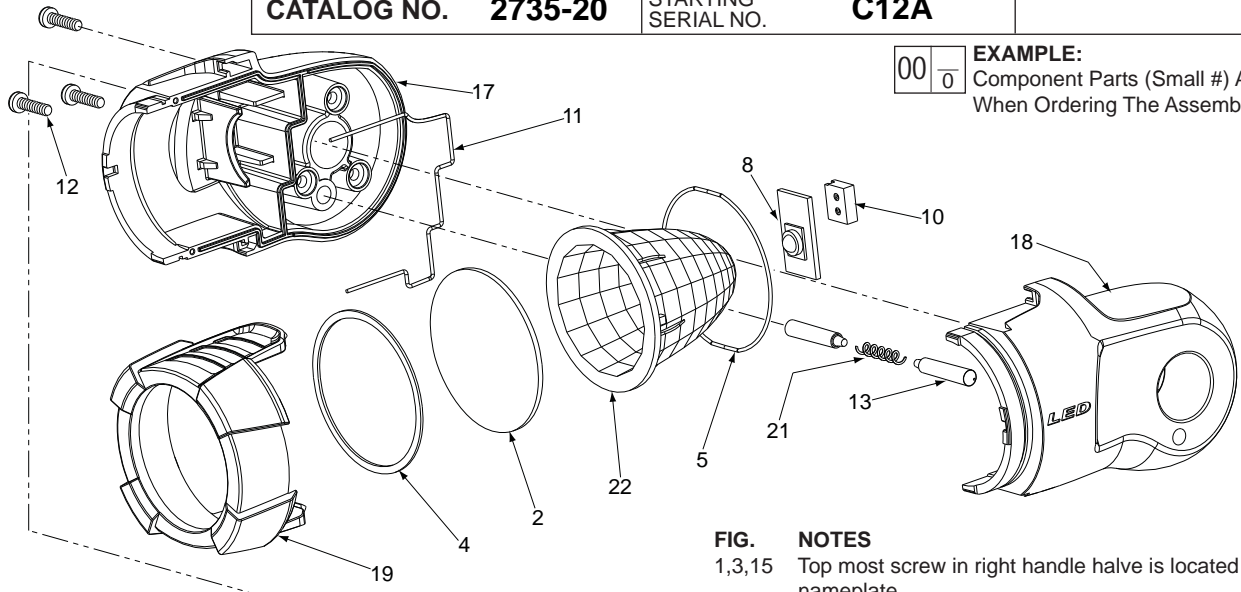

FIG. NOTES

1,3,15 Top most screw in right handle halve is located under the nameplate.

1,6 A clean, dry surface is essential for proper performance for any adhesive system. The area intended for application of any adhesive label or nameplate must be prepared by cleaning with isopropyl alcohol. The solvent is to be applied with a clean, lint free applicator and the surface allowed to dry before applying the label or nameplate.

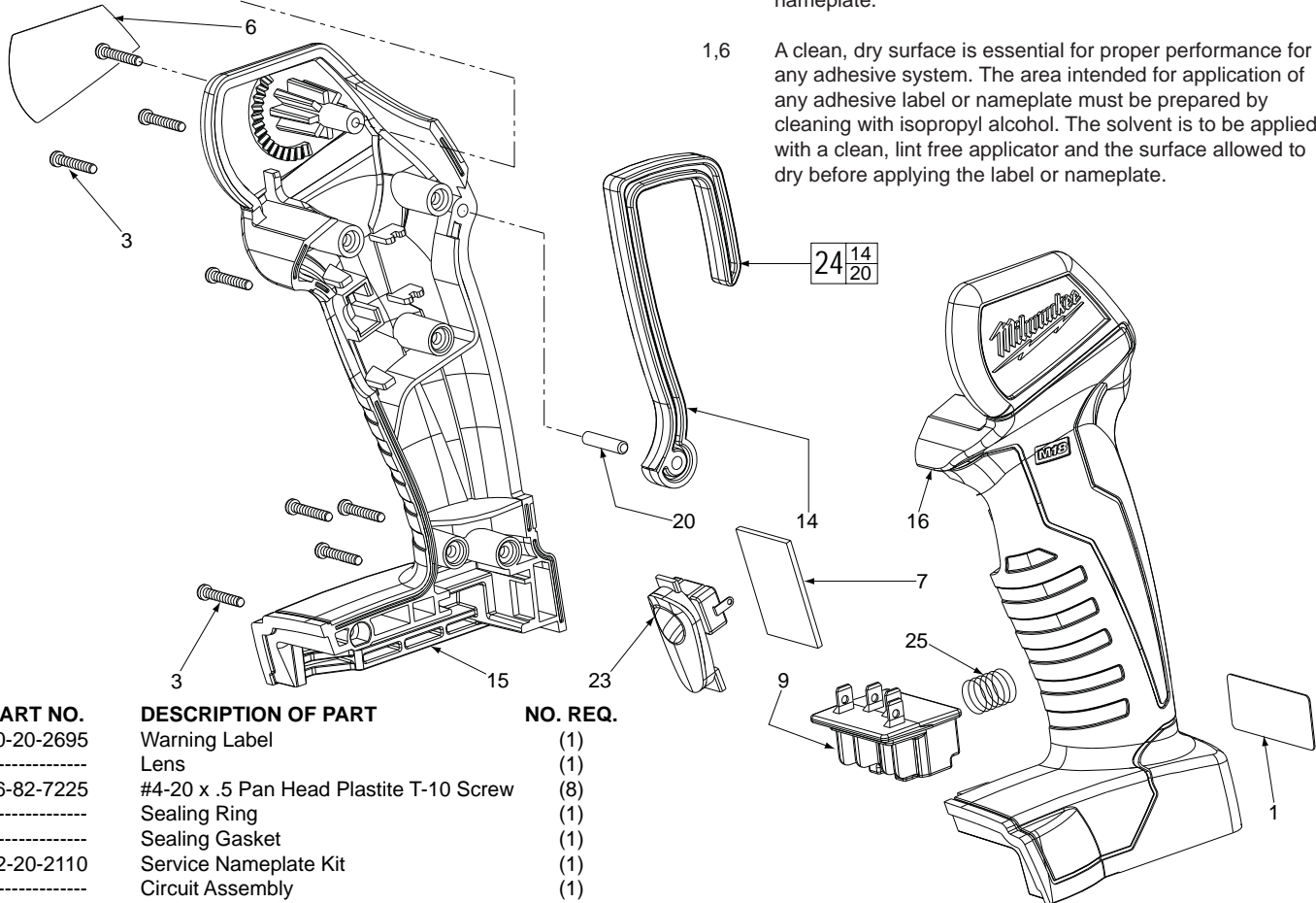

FIG.	PART NO.	DESCRIPTION OF PART	NO. REQ.
1	10-20-2695	Warning Label	(1)
2	-----	Lens	(1)
3	06-82-7225	#4-20 x .5 Pan Head Plastite T-10 Screw	(8)
4	-----	Sealing Ring	(1)
5	-----	Sealing Gasket	(1)
6	12-20-2110	Service Nameplate Kit	(1)
7	-----	Circuit Assembly	(1)
8	-----	LED	(1)
9	-----	18 V Connector Block	(1)
10	-----	Sealing Washer	(1)
11	-----	Gasket	(1)
12	-----	M3 Screw	(3)
13	-----	Detent Pin	(2)
14	-----	Hook	(1)
15	-----	Right Handle Halve	(1)
16	-----	Left Handle Halve	(1)
17	-----	Right Housing	(1)
18	-----	Left Housing	(1)
19	-----	Bezel	(1)

FIG.	PART NO.	DESCRIPTION OF PART	NO. REQ.
20	-----	Pivot Pin	(1)
21	-----	Compression Spring	(1)
22	-----	Reflector	(1)
23	-----	Push Button Switch	(1)
24	43-74-0500	Hook and Pivot Pin Assembly	(1)
25	40-50-1090	Compression Spring	(1)