



Ultra[®]

Gas-fired water boilers – Series 4



Featuring



Flexibility

Boiler Manual

- Installation
- Maintenance
- Startup
- Parts



Now with
UltraArmor[™]
 NANO-COATED
 HEAT EXCHANGER



This manual must only be used by a qualified heating installer/service technician. Read all instructions, including this manual and all other information shipped with the boiler, before installing. Perform steps in the order given. Failure to comply could result in severe personal injury, death or substantial property damage.

Contents

Hazard definitions & Ultra at-a-glance 2
 Please read before proceeding 4
 Prepare boiler location 5
 Prepare boiler 7
 Install water piping 9
 Using with Weil-McLain AQUA PLUS water heaters. 14
 Venting/air piping — general 16
 Sidewall vent/air termination: Separate pipes 20
DIRECT VENT 25
 Install condensate line 27
 Gas piping. 29
 Field wiring — basic system 30
 U-Control operation and setup 32
 Startup — fill the system 35
 Startup — final checks 37
 Check-out/startup verification. 42
 The *Ultra* Gas-fired water boiler, Featuring *U-control* Flexibility 44
 Prepare boiler — convert for propane 48
 Placing boiler — wall-mounting option 50
 Install water piping — advanced 52
 Direct-connected DHW piping. 56
 Multiple boiler installations 58
 Venting/air piping — Massachusetts installations 65
 Vent/air piping — options. 66
 Sidewall vent/air termination: Weil-McLain cap 67
 Sidewall vent/air termination: 3” or 4” concentric 72
 Vertical vent/air termination: 3” or 4” concentric 75
 Concentric vent/air termination assembly. 78
DIRECT VENT: Vertical vent / sidewall air 79
 Install vent/air piping — boiler to termination 82
DIRECT EXHAUST venting — general. 83
DIRECT EXHAUST — Boiler room air openings. 84
DIRECT EXHAUST — Sidewall 86
DIRECT EXHAUST — Vertical. 89
 Install vent — from boiler to termination 91
 Gas piping — sizing gas lines. 93
 Field wiring — advanced 94
 U-Control operation and setup — advanced 99
 Annual startup and general maintenance 108
 Annual startup. 109
 Troubleshooting. 115
 Maintenance. 125
 Replacement parts 128
 Dimensions 136
 Ratings — Ultra Series 4 boilers 137
 Installation and Service Certificate 140

Hazard definitions

The following defined terms are used throughout this manual to bring attention to the presence of hazards of various risk levels or to important information concerning the life of the product.

- ⚠ DANGER** Indicates presence of hazards that will cause severe personal injury, death or substantial property damage.
- ⚠ WARNING** Indicates presence of hazards that can cause severe personal injury, death or substantial property damage.
- ⚠ CAUTION** Indicates presence of hazards that will or can cause minor personal injury or property damage.
- NOTICE** Indicates special instructions on installation, operation or maintenance that are important but not related to personal injury or property damage.

Ultra at-a-glance

(see page 44 and page 46 for details of all models)

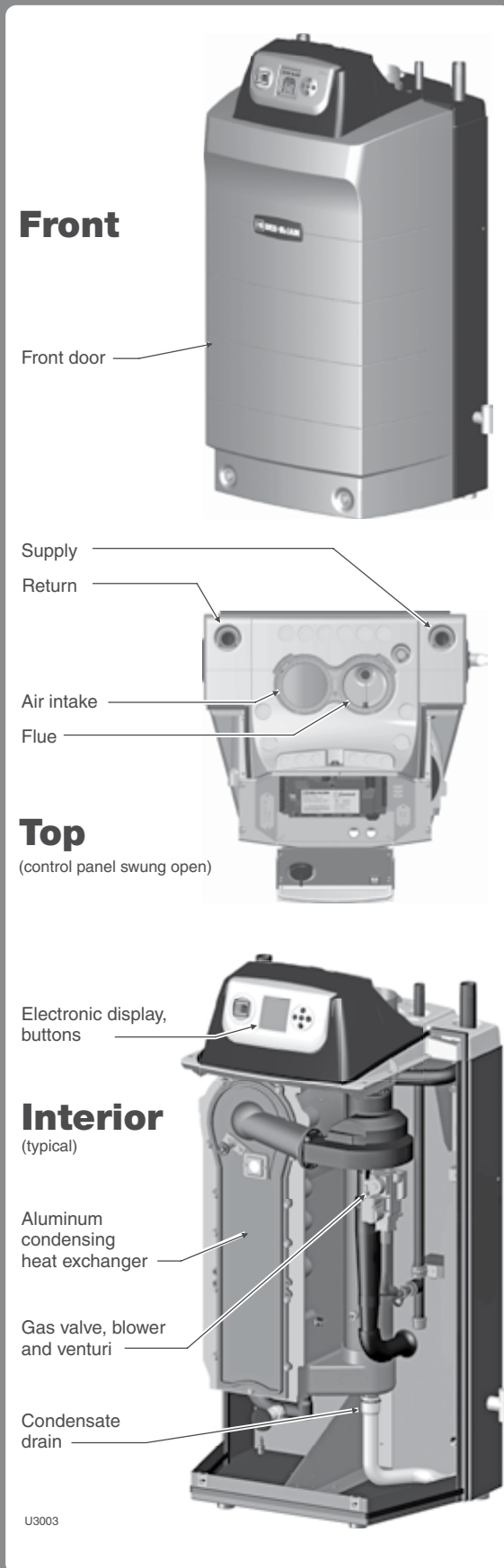

BASIC INSTALLATION

Quick view . . .

Pages	Procedure
4	Please read before proceeding <ul style="list-style-type: none"> • Read safety information before proceeding
5–6	Prepare boiler location <ul style="list-style-type: none"> • Clearances, floor and foundation • Air openings to room for ventilation
7–8	Prepare boiler <ul style="list-style-type: none"> • Make sure vent/air piping can be connected • Remove from crate • Convert for propane, if required • Hydrostatic test • Place boiler in position
9–15	Install water piping <ul style="list-style-type: none"> • Install boiler trim and near boiler piping • Complete system piping and connections
16	Appliances left on an existing vent system <ul style="list-style-type: none"> • For appliances remaining on a vent system after old boiler is disconnected — verify that the vent system works for remaining appliances
16–26	Vent/air piping <ul style="list-style-type: none"> • Locate air intake piping to prevent contaminants from entering boiler • Install vent/air termination • Install vent and air piping using acceptable materials
27–28	Install condensate piping <ul style="list-style-type: none"> • Connect condensate hose • Install condensate pump and filter, if required
29	Gas piping <ul style="list-style-type: none"> • Verify gas pipe size • Connect boiler to gas line
30–31	Field wiring <ul style="list-style-type: none"> • Connect wiring to boiler and components
32–34	U-Control operation and setup <ul style="list-style-type: none"> • U-Control operation and setup information
35–42	Start-up <ul style="list-style-type: none"> • Clean system, then fill; add inhibitor • Verify water chemistry • Purge air from system • Perform final checks • Start and operate boiler • Perform final verification tests • Fill out Installation and Service Certificate

BASIC INSTALLATION

(Pages 3–42)

This section covers basic installation and start-up for most applications. It is limited to conventional systems and to sidewall vent/air piping using the Weil-McLain termination cap.

For applications not covered in this section, see the ADVANCED INSTALLATION section.

ADVANCED INSTALLATION

(Pages 44–107)

Read and follow the instructions in the BASIC INSTALLATION section first. Then use the ADVANCED section for additional information.

This section covers multiple boiler systems and additional system types not covered under the BASIC section. It also includes alternative vent/air piping methods, water and gas pipe sizing guidelines and advanced, detailed information on the U-Control.

MAINTENANCE & SPECIFICATIONS

(Pages 108–140)

This section covers maintenance requirements for all boilers, repair parts lists, boiler dimensions and specifications.



Please read before proceeding

⚠ WARNING **Installer**— Read all instructions, including this manual and all other information shipped with the boiler, before installing. Perform steps in the order given.
User — This manual is for use only by a qualified heating installer/service technician. Refer to User’s Information Manual for your reference.
User — Have this boiler serviced/inspected by a qualified service technician, at least annually. Failure to comply with the above could result in severe personal injury, death or substantial property damage.

NOTICE Write in the CP number in the space provided on the Installation certificate on page 140 if not already shown.
 When calling or writing about the boiler— Please have the boiler model number from the boiler rating label and the CP number from the boiler jacket. Consider piping and installation when determining boiler location.
 Any claims for damage or shortage in shipment must be filed immediately against the transportation company by the consignee.

⚠ DANGER **If any part of a boiler, burner or its controls has been sprayed with or submerged under water, either partially or fully, DO NOT attempt to operate the boiler until the boiler has been either replaced or completely repaired, inspected, and you are sure that the boiler and all components are in good condition and fully reliable.**
 Otherwise, by operating this boiler, you will cause a fire or explosion hazard, and an electrical shock hazard, leading to serious injury, death, or substantial property damage. See the instructions at right.

Saltwater Damage — The exposure of boiler components to saltwater can have both immediate and long-term effects. While the immediate effects of saltwater damage are similar to those of fresh-water (shorting out of electrical components, washing out of critical lubricants, etc.), the salt and other contaminants left behind can lead to longer term issues after the water is gone due to the conductive and corrosive nature of the salt residue. Therefore, Weil-McLain equipment contaminated with saltwater or polluted water will no longer be covered under warranty and should be replaced.
Electrical Damage — If any **electrical component or wiring** came into contact with water, or was suspected to have come into contact with water, replace the boiler with a new Weil-McLain boiler.

⚠ WARNING Failure to adhere to the guidelines below can result in severe personal injury, death or substantial property damage.

When servicing boiler —

- To avoid electric shock, disconnect all electrical supplies to the boiler before performing maintenance.
- To avoid severe burns, allow boiler to cool before performing maintenance.
- This boiler contains ceramic fiber and fiberglass materials. Refer to the WARNING and instructions on page 109.

Boiler operation —

- Do not block flow of combustion or ventilation air to boiler.
- Should overheating occur or gas supply fail to shut off, do not turn off or disconnect electrical supply to pump. Instead, shut off the gas supply at a location external to the appliance.

Combustion air —

- DO NOT install combustion air intake where there is a risk of combustion air contamination.

Carbon monoxide detector —

- A carbon monoxide detector that is wired on the same electrical circuit as the boiler is strongly recommended.

SURGE PROTECTOR —

- Provide surge protection in the boiler power supply. This will reduce the possibility of damage to the boiler control.

Boiler water —

- The Ultra heat exchanger is made of aluminum, and requires that system pH always be between 7.0 and 8.5 and water chemistry be checked. Chemical treatment may be necessary. **ADDITIONAL CHEMICAL TREATMENT MAY BE NECESSARY.** See page 35 for details.
- Thoroughly flush the system (**BEFORE** connecting boiler) to remove sediment. The high-efficiency heat exchanger can be damaged by build-up or corrosion due to sediment.
- Do not use petroleum-based cleaning or sealing compounds in boiler system. Gaskets and seals in the system may be damaged. This can result in substantial property damage.
- Continual fresh make-up water will reduce boiler life. Mineral buildup in heat exchanger reduces heat transfer, overheats the aluminum heat exchanger, and causes failure. Addition of oxygen carried in by make-up water can cause internal corrosion. Leaks in boiler or piping must be repaired at once to prevent make-up water. Use this boiler **ONLY** in a closed-loop system.
- Do not add cold water to a hot boiler. Thermal shock can cause heat exchanger to crack.

Freeze protection fluids —

- NEVER use automotive or standard glycol antifreeze. Use only freeze-protection fluids made for hydronic systems. Use only freeze-protection fluids recommended in this manual (see page 35). Follow all guidelines given by the antifreeze manufacturer. Thoroughly clean and flush any replacement boiler system that has used glycol before installing the new Ultra boiler

⚠ CAUTION **Frozen Water Damage Hazard**

Residences or buildings that are unattended in severely cold weather, boiler system components failures, power outages, or other electrical system failures could result in frozen plumbing and water damage in a matter of hours. For your protection, take preventative actions such as having a security system installed that operates during power outages, senses low temperature, and initiates an effective action. Consult with your boiler contractor or a home security agency.

Commonwealth of Massachusetts

- When the boiler is installed within the Commonwealth of Massachusetts:
- This product must be installed by a licensed plumber or gas fitter.
 - If antifreeze is used, a reduced pressure back-flow preventer device shall be used.
 - Sidewall vent air installations — see instruction on page 65.

Prepare boiler location

Installations must comply with:

- Local, state, provincial, and national codes, laws, regulations and ordinances.
- National Fuel Gas Code, ANSI Z223.1 /NFPA 54 – latest edition.
- Standard for Controls and Safety Devices for Automatically Fired Boilers, ANSI/ASME CSD-1, when required.
- National Electrical Code.
- For Canada only: Natural Gas and Propane Installation Natural Gas and Propane Installation CAN/CSA B149.1 or B149.2 Installation Code, CSA C22.1 Canadian Electrical Code Part 1 and any local codes.

NOTICE The Ultra boiler gas manifold and controls met safe lighting and other performance criteria when boiler underwent tests specified in ANSI Z21.13 — latest edition.

Before locating the boiler, check:

1. Check for nearby connection to:
 - System water piping
 - Venting connections
 - Gas supply piping
 - Electrical power
 - Condensate drain
2. Check area around boiler. Remove any combustible materials, gasoline and other flammable liquids.

WARNING Failure to keep boiler area clear and free of combustible materials, gasoline and other flammable liquids and vapors can result in severe personal injury, death or substantial property damage.

3. The Ultra boiler must be installed so that gas control system components are protected from dripping or spraying water or rain during operation or service.
4. If new boiler will replace existing boiler, check for and correct system problems, such as:
 - System leaks causing oxygen corrosion or heat exchanger cracks from hard water deposits.
 - Incorrectly-sized expansion tank.
 - Lack of freeze protection in boiler water causing system and boiler to freeze and leak.

Provide clearances:

Clearances from combustible materials

1. Hot water pipes — at least 1/2" from combustible materials.
2. Vent pipe — at least 3/16" from combustible materials.
3. See Figure 1 for other clearance minimums.

Figure 1 Clearances required

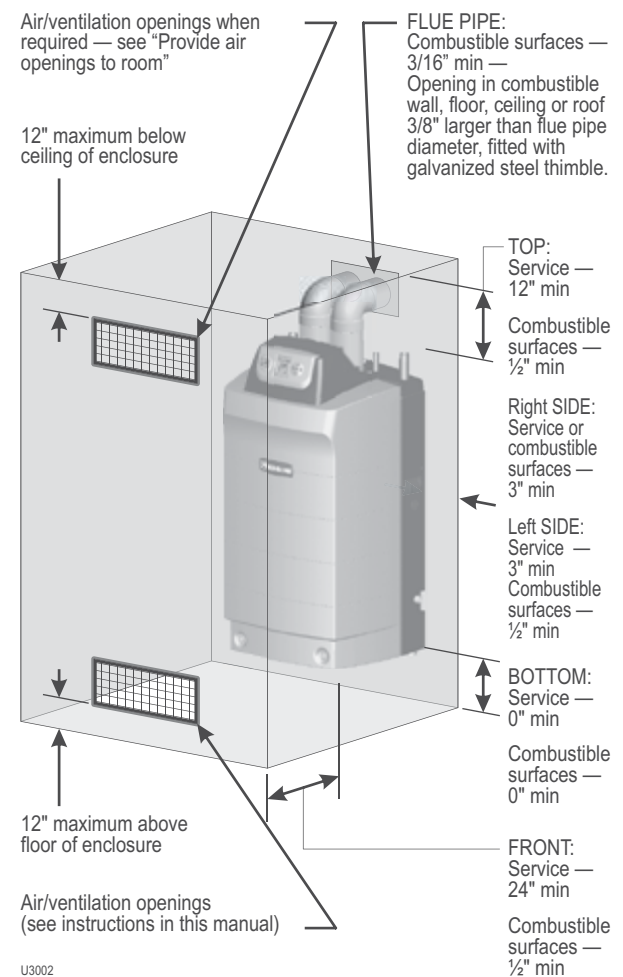

Clearances for service access

1. See Figure 1 for recommended service clearances. If you do not provide minimum clearances shown, it might not be possible to service the boiler without removing it from the space.

Wall mounting option

1. Ultra boilers can be wall mounted (using special wall mount kit) or floor mounted. **No clearance is required at the rear of the unit**, either for service or for clearance to combustible surfaces.
2. Boilers can be wall mounted ONLY if using the optional wall-mount kit available from Weil-McLain. See page 50 for instructions.



Prepare boiler location *(continued)*

Flooring and foundation

Flooring

The Ultra boiler is approved for installation on combustible flooring, but must never be installed on carpeting.

▲WARNING Do not install boiler on carpeting even if foundation is used. Fire can result, causing severe personal injury, death or substantial property damage.

Foundation

1. Provide a solid foundation pad, at least 2 inches above the floor, if any of the following is true:
 - floor can become flooded.
 - the floor is dirt, sand, gravel or other loose material.
 - the boiler mounting area is severely uneven or sloped.
2. The minimum foundation size is:
 - Ultra-80 to -230: 24 inches wide x 20 inches deep.
 - Ultra-299 to -399: 24 inches wide x 23 inches deep.
3. Foundation may be of wood, brick or concrete (minimum 2 inches thick) construction.
4. If flooding is possible, elevate boiler sufficiently to prevent water from reaching boiler.

Residential garage installation

Precautions

Take the following special precautions when installing the boiler in a residential garage. If the boiler is located in a residential garage:

- Mount the boiler at a height above the floor as specified in the National Fuel Gas Code, ANSI Z223.1 NFPA 54 for U. S. installations, or Natural Gas and Propane Installation CAN/CSA B149.1 and B149.2 for Canadian installations.
- Locate or protect the boiler so it cannot be damaged by a moving vehicle.
- Ensure that the installation complies with all applicable codes.

Provide air openings to room

Air openings — Ultra boiler alone in boiler room

1. No air ventilation openings into boiler room are needed when clearances around Ultra boiler are at least equal to the SERVICE clearances shown in Figure 1, page 5.
2. For spaces that do NOT supply this clearance, provide two openings as shown in Figure 1, page 5. Each opening must provide 1 square inch free area per 1,000 Btuh of boiler input.

Air openings — Ultra boiler in same space with other gas or oil-fired appliances

1. Follow the National Fuel Gas Code (U. S.) or Natural Gas and Propane Installation CAN/CSA B149.1 and B149.2 (Canada) to size/verify size of the combustion/ventilation air openings into the space.

▲WARNING

The space must be provided with combustion/ventilation air openings correctly sized for all other appliances located in the same space as the Ultra boiler.

Reinstall boiler jacket front door after servicing. The boiler front door must be securely fastened to the boiler to prevent boiler from drawing air from inside the boiler room. This is particularly important if the boiler is located in the same room as other appliances.

Failure to comply with the above warnings could result in severe personal injury, death or substantial property damage.

2. Size openings only on the basis of the other appliances in the space. No additional air opening free area is needed for the Ultra boiler because it takes its combustion air from outside (direct vent installation).

Prepare boiler

Vent and air piping (page 16)

1. The Ultra boiler requires a special vent system, designed for pressurized venting. Ultra boilers are rated ANSI Z21.13 Category IV (pressurized vent, likely to condense in the vent). See instructions beginning on page 16.
2. You must also install air piping from outside to the boiler air intake adapter. The resultant installation is categorized as direct vent (sealed combustion). Note prevention of combustion air contamination on page 16 when considering vent/air termination.
3. Vent and air must terminate near one another and may be vented vertically through the roof or out a side wall. You may use any of the vent/air piping methods covered in this manual. Do not attempt to install the Ultra boiler using any other means.
4. Be sure to locate the boiler such that the vent and air piping can be routed through the building and properly terminated. The vent/air piping lengths, routing and termination method must all comply with the methods and limits in instructions beginning on page 16.

Remove boiler from crate

CAUTION Cold weather handling — If boiler has been stored in a very cold location (below 0°F) before installation, handle with care until the plastic components come to room temperature.

1. The Ultra boiler is generally easier to handle and maneuver after removing from crate.
2. After removing outer shipping carton from boiler, REMOVE jacket front door by loosening two (2) screws at lower front. Removing the door will prevent possible damage to the door during handling.
3. To remove boiler from pallet (after removing jacket front door):
 - a. Remove the lag screws securing the shipping brackets.
 - b. Unscrew the two rear boiler legs and remove the shipping brackets.
 - c. Replace legs.
 - d. Discard the cardboard protector insert on the rear of the boiler.

NOTICE Do not drop boiler or bump jacket on floor or pallet. Damage to boiler can result.

Prepare boiler for propane (when required)

Propane operation

WARNING Ultra boilers must be converted for propane operation unless specifically manufactured for propane. Propane-ready boilers have suffix “LP” after the model number. All other boilers require conversion for propane operation.

Refer to propane conversion instructions beginning on page 48.

Failure to comply could result in severe personal injury, death or substantial property damage.

Placing floor-mounted boilers

1. Set boiler in place and check level.
 - a. Adjust legs, if necessary to level boiler.

Wall-mounted boilers

1. Boilers can be wall mounted ONLY if using the optional wall-mount kit available from Weil-McLain. See page 50 for instructions.



Prepare boiler *(continued)*

WARNING DO NOT install a relief valve with a pressure higher than 30 PSIG. This is the maximum allowable relief valve setting for the Ultra boiler.

Perform hydrostatic pressure test

Pressure test boiler before permanently attaching water or gas piping or electrical supply.

Prepare boiler for test

1. See Figure 2 for reference in following steps.
2. Remove supply line tees* and 3/4" elbow from accessory bag. Pipe to boiler supply connection as shown. Use pipe dope sparingly. (* 1"x1"x1/4" and *1"x1"x3/4" tees with Ultra-80 to -230 or * 1-1/4"x1-1/4"x1/4" and *1-1/4"x1-1/4"x3/4" tees with Ultra 299/399.
3. Temporarily plug the 3/4" relief valve tapping in the street elbow with a 3/4" NPT pipe plug.
4. Connect a hose to the boiler drain valve, the other end connected to a fresh water supply. Make sure the hose can also be used to drain the boiler after test.
5. Connect a nipple and shutoff valve to system supply connection on the supply tee. This valve will be used to bleed air during the fill. (Valve and nipple are not included with boiler.)
6. Connect a shutoff valve to system return connection. (Valve is not included with boiler.)
7. To avoid getting water on boiler, you may want to pipe street elbows on top of shutoff valves and attach catch-buckets beneath.
8. If convenient, install the boiler circulator and any other piping compatible with Figure 2 that would still allow bleeding air from shutoff valves.
9. Follow guidelines in this manual for piping components, locations and sizing.

Fill and pressure test

1. Open the shutoff valves you installed on supply and return connections.
2. Slowly open boiler drain valve and fresh water supply to fill boiler with water. The boiler will fill quickly because of its low water content.
3. When water reaches shutoff valves, close boiler drain valve.
4. Close shutoff valves.
5. Slowly reopen boiler drain valve until test pressure on the pressure/temperature gauge reaches at least 45 psig, but no higher than 55 psig.
6. Hold at test pressure for 10 minutes.

WARNING Do not leave boiler unattended. A cold water fill could expand and cause excessive pressure, resulting in severe personal injury, death or substantial property damage.

7. Make sure constant gauge pressure has been maintained throughout test. Check for leaks. Repair if found.

WARNING Leaks must be repaired at once. Failure to do so can damage boiler, resulting in substantial property damage.

Figure 2 Hydrostatic test piping connections

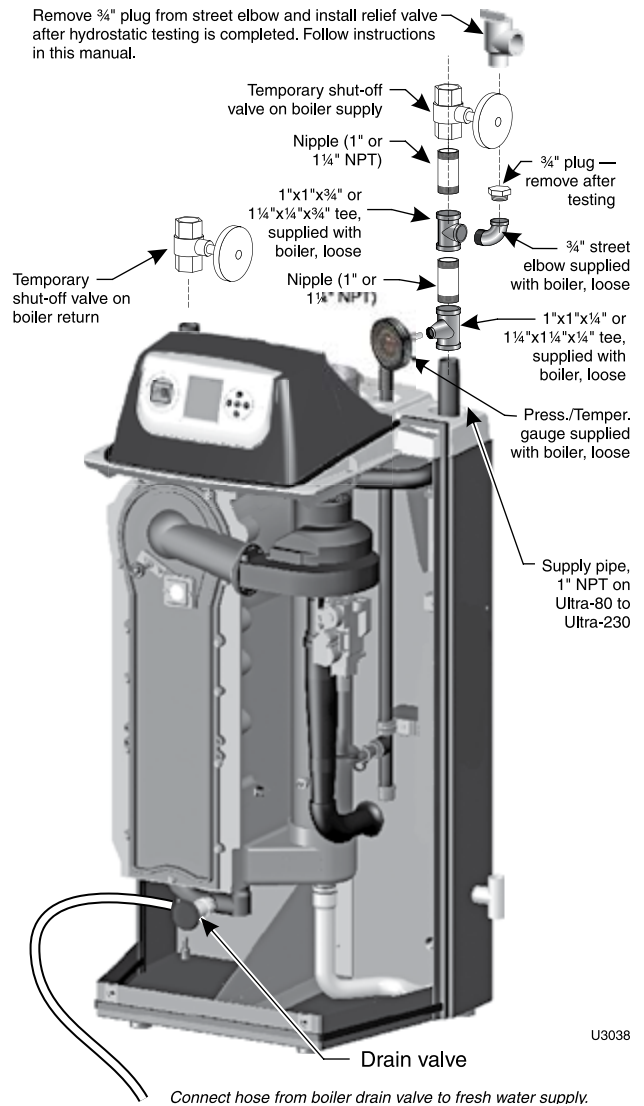

WARNING Do not use petroleum-based cleaning or sealing compounds in boiler system. Gaskets and seals in the system may be damaged. This can result in substantial property damage.

Drain and remove fittings

1. Disconnect fill water hose from water source.
2. Drain boiler through drain valve. Remove hose after draining.
3. Remove nipples and valves unless they will remain for use in the system piping.
4. Remove plug from relief valve street elbow. See page 9 to install relief valve.

Install water piping

▲WARNING Use two wrenches when tightening water piping at boiler, using one of the wrenches to prevent the boiler interior piping from turning. Failure to support the boiler piping connections to prevent them from turning could cause damage to boiler components.

General piping information

Additional controls, when required

NOTICE The U-Control module uses temperature sensors to provide both high limit protection and modulating temperature control. The U-Control module also provides low water protection by sensing the temperature of the heat exchanger. Some codes/jurisdictions may require additional external controls for high limit and/or low water cutoff protection.

Additional limit controls

Following standard industry practices, if installation is to comply with ASME or Canadian requirements, an additional high temperature limit may be needed. Consult local requirements for other codes/standards to determine if needed.

1. Install a manual reset high temperature limit constructed to prevent a temperature setting above 200°F in system supply piping between boiler and isolation valve. (Note that the U-Control module operating limit function shuts the boiler down at 195°F, or lower if set to a lower value.)

▲WARNING **Multi-temperature systems** — If the heating system includes circuits that require lower temperature water (radiant slab circuits, for example) as well as higher temperature circuits, it is recommended to protect low-temperature circuits with limit controls that are wired to a U-Control external limit circuit (P13 terminals 1 and 2 for manual reset, or P13 terminals 3 and 4 for automatic reset).

2. See instructions beginning on page 30 for wiring information.
 - a. Manual reset operation: If external limit controls are to cause **manual reset** of the U-Control module, connect series-wired isolated contacts to P13 terminals 1 and 2 (see page 30 for wiring information).
 - b. Automatic reset operation: If external limit controls are to cause **automatic reset** of the U-Control module, connect series-wired isolated contacts to P13 terminals 3 and 4 (see page 30 for wiring information).
 - c. If using a manual reset limit control or wiring in the manual reset circuit, set U-Control boiler limit at least 20°F less than the external manual reset limit (i.e., set U-Control no higher than 180°F for a 200°F external limit, for example).

Separate low water cutoff

1. A low water cutoff device is recommended when the boiler is installed above piping level, and may be required by certain state or local codes or insurance companies. Consult local requirements to determine. See the NOTICE above regarding the inherent protection provided by the U-Control module.
2. The U-Control's integral protection is accepted in many jurisdictions as meeting the requirement for low water protection. See page 95 for details.

3. When required, use a low water cutoff designed for water installations. Electrode probe-type is recommended. See Replacement parts section at the end of this manual for the Weil-McLain low water cut-off kit.
4. Purchase low water cutoff and install in a tee in the supply piping above boiler.
5. See field wiring instructions beginning on page 30 for wiring additional limit controls.

Backflow preventer

1. Use backflow check valve in cold water supply as required by local codes.

Install relief valve

1. Install relief valve in ¾" street elbow piped from boiler supply piping tee (Figure 2, page 8). Pipe the relief valve only as shown, in the location shown.
2. Connect discharge piping to safe disposal location, following guidelines in the **WARNING** below.

▲WARNING **To avoid water damage or scalding due to relief valve operation, as per local or state codes:**

Discharge line must be connected to relief valve outlet and run to a safe place of disposal. Terminate the discharge line in a manner that will prevent possibility of severe burns or property damage should the valve discharge.

Discharge line must be as short as possible and be the same size as the valve discharge connection throughout its entire length.

Discharge line must pitch downward from the valve and terminate at least 6" above the floor drain where any discharge will be clearly visible.

The discharge line shall terminate plain, not threaded, with a material serviceable for temperatures of 375 °F or greater.

Do not pipe the discharge to any place where freezing could occur.

No shutoff valve shall be installed between the relief valve and boiler, or in the discharge line. Do not plug or place any obstruction in the discharge line.

Test the operation of the valve after filling and pressurizing system by lifting the lever. Make sure the valve discharges freely. If the valve fails to operate correctly, replace it with a new relief valve.

Failure to comply with the above guidelines could result in failure of the relief valve to operate, resulting in possibility of severe personal injury, death or substantial property damage.



Install water piping *(continued)*

System water piping methods

NOTICE All piping methods shown in this manual use primary/secondary connection to the boiler loop. These designs ensure proper flow through the Ultra boiler, for the most efficient and reliable operation of the boiler and the heating system. For other piping methods, consult your local Weil-McLain representative or see separate Ultra boiler piping guides.

Circulators

The boiler circulator (Taco 007 for Ultra-80 and -105; Taco 0014 for Ultra-155, -230, and -299; Taco 0013 for Ultra-399) is shipped loose. Locate it in the return piping, as shown in the appropriate piping diagram in this manual.

WARNING **DO NOT** use the boiler circulator in any location other than the ones shown in this manual. The boiler circulator is selected to ensure adequate flow through the Ultra boiler.

Install the boiler circulator only on the boiler return piping. This ensures the pressure drop through the boiler will not cause low pressure in the circulator intake.

Failure to comply could result in unreliable performance and nuisance shutdowns from insufficient flow.

Circulator flow rate

Size circulators based on the flow rate required to achieve the temperature change needed. You can closely estimate temperature rise (or drop) through a circuit by using the following formula, where TD is temperature rise (or drop), FLOW is flow rate (in gpm), and BTUH is the heat load for the circuit:

$$\text{FLOW} = \frac{\text{BTUH}}{\text{TD} \times 500}$$

Examples:

Consider a system loop for a system with total heating load equal to 210,000 Btuh. The desired temperature drop through the system piping is 20°F. Then the required flow rate is:

$$\text{FLOW} = \frac{210,000}{20 \times 500} = 21 \text{ gpm}$$

SIMPLIFIED: For 20° temperature drop, FLOW = MBH / 10.

Circulator head requirement

The circulator must be capable of delivering the required flow against the head loss that will occur in the piping. Determine the pipe size needed and the resultant head loss using accepted engineering methods. The simplified pipe sizing here is limited to residential systems, and does not include systems with fan coil units or radiant tubing.

CAUTION The following simplified method for pipe and circulator sizing must be limited to residential applications using baseboard (finned or cast iron), cast iron radiators or convectors. **DO NOT** apply for radiant heating, fan coil units or commercial installations.

Simplified pipe/circulator selection

1. Install the boiler and piping using the recommended piping layouts beginning on page 12 and in the ADVANCED section of this manual.
2. Size the piping and components for each circuit in the space heating system using Figure 3. **At the flow rates listed, the head loss in all piping will be 0.04 feet per foot of pipe.**
 - a. Determine the heating load (Btuh) for each circuit.
 - b. Calculate the flow rate for each circuit using its load.
To use a 20°F temperature drop, just divide the MBH (1,000's of Btuh) by 10.
Example — Flow for 20°F temp drop with 35,000 Btuh:
FLOW = 35 MBH / 10 = 3.5 gpm
 - c. Find the pipe size in Figure 3 that has a max flow rate just larger than that required for the circuit.
 - d. Find the total equivalent length (TEL) of the circuit.
TEL accounts for losses through fittings and valves by using the equivalent length of pipe that would cause the same head loss. Add these numbers to the measured length of the circuit to find TEL in feet.
TEL is usually close to 1.5 times the length of the circuit for residential baseboard, radiator or convector applications.
 - e. Measure the length of each circuit from the circulator outlet back to its inlet. Then multiply this length times 1.5 to get the approximate TEL of the circuit.
 - f. Find the head loss for each circuit:

$$\text{TEL} = 1.5 \times \text{Circuit Length (feet)}$$

$$\text{HEAD} = \text{TEL} \times 0.04 \text{ (feet water column)}$$

- g. NOTE: Size system header piping for the total flow of all connected zones.
3. Example:
 - a. For a circuit with heating load = 45,000 Btuh (= 45 MBH). Measured length of circuit is 88 feet.
 - b. Flow = 45 MBH / 10 = 4.5 gpm.
 - c. TEL = 1.5 x 88 feet = 132 feet.
 - d. From Figure 3, select 1" pipe (max flow = 7.1 gpm).
 - e. Head loss = TEL x 0.04 = 132 x 0.04 = 5.28 feet.
 - f. Select a circulator that can deliver at least 4.5 gpm at a head of 5.28 feet. (Read the NOTICE below.)

NOTICE To use this method, limit the flow through ¾" finned-tube baseboard to 3.9 gpm, or use 1" baseboard and limit flow to 7.1 gpm. If the total load of the circuit requires more flow, split the circuit into two or more.

Also see Figure 10, page 15 for quick-selection information for applications using Taco 007 circulators or equivalent for zone piping.

Figure 3 Flow rates for **0.04 feet head loss per foot** of pipe (140°F water)

Pipe size (inches)	MAX Flow rate (GPM) @ 0.04 feet per foot	Pipe size (inches)	MAX Flow rate (GPM) @ 0.04 feet per foot
¾	3.9	2	45
1	7.1	2½	75
1¼	16	3	140
1½	24	4	290



Install water piping *(continued)*

Expansion tank and make-up water

1. Ensure expansion tank size will handle boiler and system water volume and temperature. Allow 3 gallons for boiler and its piping.

CAUTION Undersized expansion tanks cause system water to be lost from relief valve and make-up water to be added through fill valve. Eventual boiler failure can result due to excessive make-up water addition.

2. Tank must be located as shown in this manual, or following recognized design methods. See tank manufacturer's instructions for details. When installing air vents and expansion tanks, refer to manufacturer's instructions.
3. Connect the expansion tank to the air separator only if the separator is on the suction side of the circulator. Always install the system fill connection at the same point as the expansion tank connection to the system.
4. Most piping drawings in this manual show diaphragm expansion tanks. See Figure 4 for piping from air separator to expansion tank and make-up water line using a closed-type expansion tank.
5. Most chilled water systems are piped using a closed-type tank, as shown in Figure 51, page 55.

Diaphragm (or bladder) expansion tank

1. (Figure 4) Always install an automatic air vent on top of the air separator to remove residual air from the system.

NOTICE When using diaphragm or bladder tanks only — when the boiler is installed above the system main piping, install an automatic air vent in the top of the outgoing boiler piping to prevent air pocketing.

Closed-type expansion tank

1. See Figure 4, Alternate, for piping connections when using a closed-type expansion tank.
2. Pitch any horizontal piping up towards tank 1 inch per 5 feet of piping. Connect to tank with at least 3/4" piping to allow room for air to rise.

CAUTION DO NOT install automatic air vents on closed-type expansion tank systems. Air must remain in the system and return to the tank to provide its air cushion. An automatic air vent would cause air to leave system, resulting in water-logging the expansion tank.

DO NOT use a closed-type expansion tank on a system with a Weil-McLain AQUA PLUS water heater. The water heater must use an automatic air vent. Operation of the automatic air vent will deplete air in the piping, causing the expansion tank to waterlog.

CAUTION Use **at least** the **MINIMUM** pipe size shown in Figure 4 on all boiler loop piping (connecting boiler to and from the primary/secondary connection, item 9). **Use only primary/secondary piping as shown.** Failure to follow these guidelines could result in system problems.

Figure 4 Expansion tank piping

Piping to diaphragm (or bladder) expansion tank

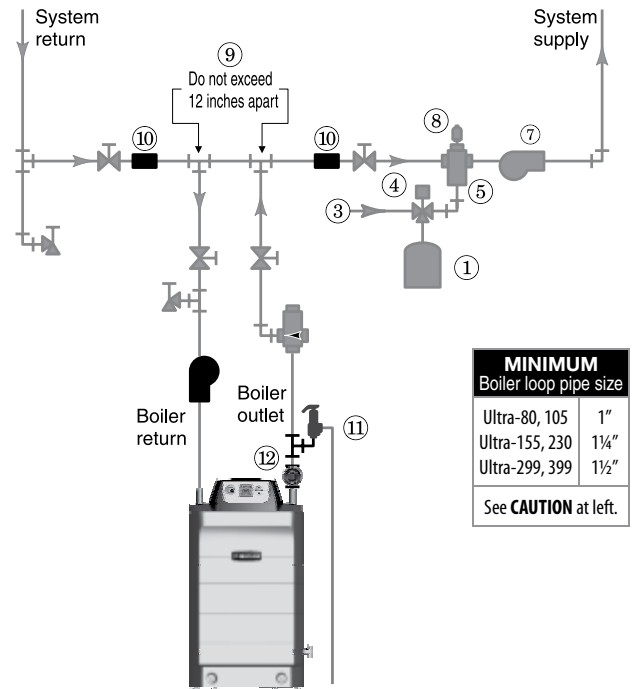

MINIMUM Boiler loop pipe size	
Ultra-80, 105	1"
Ultra-155, 230	1¼"
Ultra-299, 399	1½"

See **CAUTION** at left.

Alternate — Piping to closed-type expansion tank

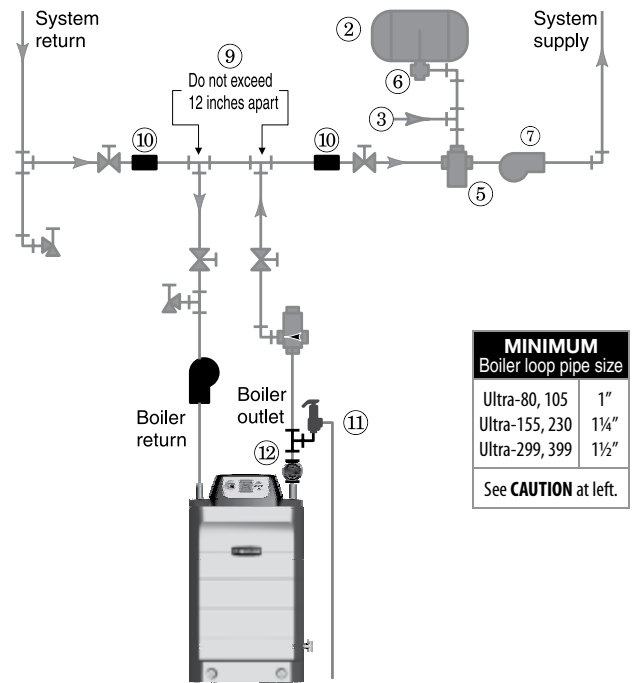

MINIMUM Boiler loop pipe size	
Ultra-80, 105	1"
Ultra-155, 230	1¼"
Ultra-299, 399	1½"

See **CAUTION** at left.

- ① Diaphragm-type expansion tank
- ② Closed-type expansion tank
- ③ Make-up water supply
- ④ Fill valve, typical
- ⑤ Air separator
- ⑥ Tank fitting
- ⑦ System circulator
- ⑧ Automatic air vent
- ⑨ Primary/secondary connection
- ⑩ System supply/return sensors
- ⑪ Relief valve
- ⑫ Temperature/Pressure gauge

U3039



Install water piping — typical systems

Zoning with zone valves

1. Connect boiler to system as shown in Figure 5 when zone valve zoning. The primary/secondary piping shown ensures the boiler loop will have sufficient flow. It also avoids applying the high head of the boiler circulator to the zone valves. Also see the information on page 14 and page 15 for suggested piping and sizing.

CAUTION Use **at least the MINIMUM** pipe size shown in Figure 5 on all boiler loop piping (connecting boiler to and from the primary/secondary connection, item 21). **Use only primary/secondary piping as shown.** Failure to follow these guidelines could result in system problems.

2. When using a closed-type expansion tank, connect the expansion tank and make-up water piping as shown in Figure 4, page 11. (DO NOT use a closed-type tank with a AQUA PLUS water heater.)

3. Connect DHW (domestic hot water) piping to indirect storage water heater as shown.

NOTICE By default, the U-Control Module turns off space heating during DHW heating (if DHW input is priority 1). The boiler circulator will turn off, preventing hot water from circulating to the system (optional time out setting can be used to override). The flow/check valve shown on the boiler outlet piping prevents gravity circulation in the boiler loop during DHW heating.

NOTICE Overriding the Outdoor Reset function by setting control to DHW mode when system is intended for space heating may violate **Section 303 of the 2007 Energy Act**. See page 137 for compliance information and exemptions.

4. Controlling the circulators

- The U-Control can control up to three circulators (boiler circulator and two others). Refer to Field wiring, beginning on page 30, for instructions on wiring to circulators.
- The factory default settings are: DHW circulator as Circulator 1, boiler circulator as Circulator 2 and system circulator as Circulator 3. See Field wiring instructions, beginning on page 30, for details.

Figure 5 Zone valve zoning plus optional DHW piping

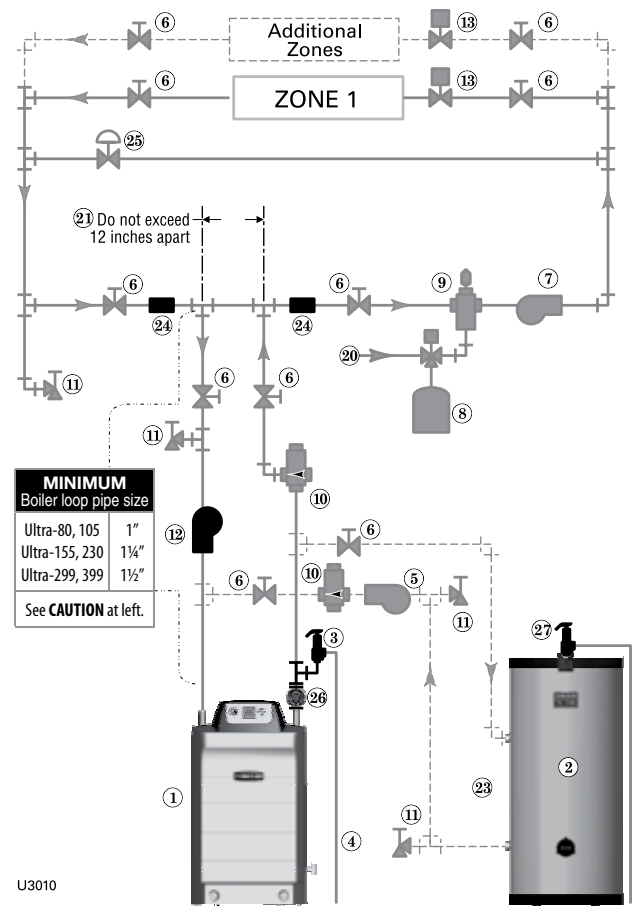

U3010

Legend — Figure 5

1 Ultra boiler	12 Boiler circulator
2 Indirect water heater (DHW), if used	13 Zone valves, typical
3 Boiler relief valve (see page 9 for piping details)	20 Make-up water supply
4 Relief valve discharge piping (see page 9 for details)	21 Primary/secondary connection
5 DHW circulator (see page 56 for suggested sizing)	23 DHW connections — see water heater manual for piping
6 Isolation valves	24 Strap system supply and return sensors to lines as shown, at least 6 pipe diameters (but no more than 3 feet) from boiler connection tees.
7 System circulator (see information above for wiring)	25 Systems using high-head pumps may require a bypass pressure regulator to prevent damage to control valves.
8 Diaphragm (or bladder) type expansion tank (see page 56 for piping of closed-type expansion tank, if used)	26 Temperature/Pressure gauge
9 Air separator [with automatic air vent only on systems using diaphragm (or bladder) type expansion tank]	27 DHW relief valve, if used
10 Flow/check valves	■ Items supplied with boiler
11 Purge/drain valves	■ Items supplied by others

Other piping alternatives

See page 14 and page 15 and ADVANCED INSTALLATION section for additional piping suggestions.

Install water piping — typical systems *(continued)*

Zoning with circulators

1. Connect boiler to system as shown in Figure 6 when circulator zoning. The boiler circulator cannot be used for a zone. It must supply only the boiler loop. Also see the information on page 14 and page 15 for suggested piping and sizing.

CAUTION Use **at least the MINIMUM** pipe size shown in Figure 6 on all boiler loop piping (connecting boiler to and from the primary/secondary connection, item 21). **Use only primary/secondary piping as shown.** Failure to follow these guidelines could result in system problems.

2. Install a separate circulator for each zone.
3. When using a closed-type expansion tank, connect the expansion tank and make-up water piping as shown in Figure 4, page 11. (DO NOT use a closed-type tank with a AQUA PLUS water heater.)
4. Connect DHW (domestic hot water) piping to indirect storage water heater as shown.

NOTICE By default, the U-Control Module turns off space heating during DHW heating (if DHW input is priority 1). The boiler circulator will turn off, preventing hot water from circulating to the system (optional timeout setting can be used to override). The flow/check valve shown on the boiler outlet piping prevents gravity circulation in the boiler loop during DHW heating.

NOTICE Overriding the Outdoor Reset function by setting control to DHW mode when system is intended for space heating may violate **Section 303 of the 2007 Energy Act**. See page 137 for compliance information and exemptions.

5. Controlling the circulators
 - a. The U-Control can control up to three circulators (boiler circulator and two others). Refer to Field wiring, beginning on page 30, for instructions on wiring to circulators.
 - b. The factory default settings are: DHW circulator as Circulator 1, boiler circulator as Circulator 2. See Field wiring instructions, beginning on page 30, for details.
 - c. The zone circulators in Figure 6 must be controlled by circulator relays activated by the zone thermostats or zone controller.

Figure 6 Circulator zoning plus optional DHW piping

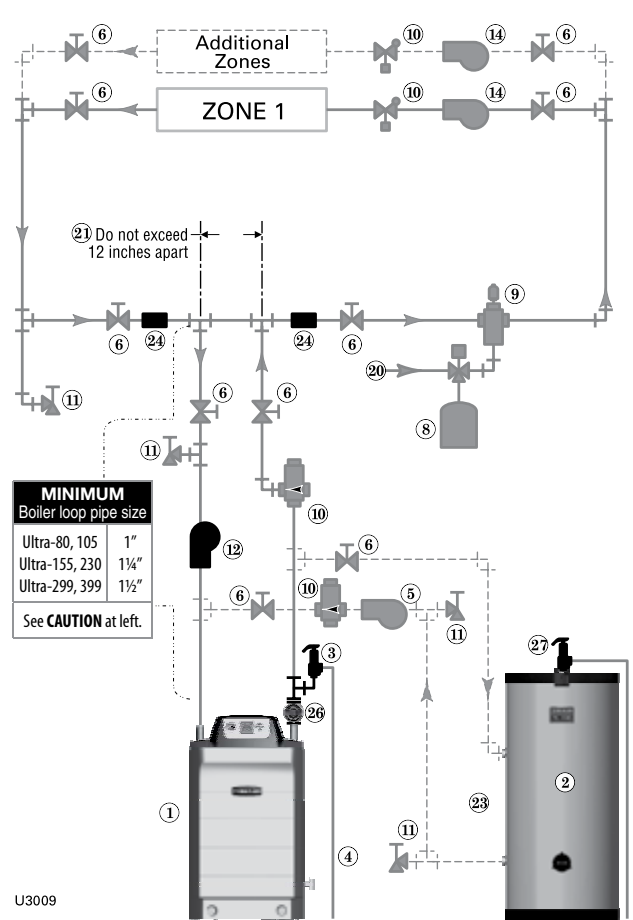

U3009

MINIMUM Boiler loop pipe size	
Ultra-80, 105	1"
Ultra-155, 230	1 1/4"
Ultra-299, 399	1 1/2"

See CAUTION at left.

BASIC INSTALLATION

Legend — Figure 6

1 Ultra boiler	11 Purge/drain valves
2 Indirect water heater (DHW), if used (see page 56)	12 Boiler circulator
3 Boiler relief valve (see page 9 for piping details)	14 Zone circulators, typical
4 Relief valve discharge piping (see page 9 for details)	20 Make-up water supply
5 DHW circulator (see page 56 for suggested sizing)	21 Primary/secondary connection (tees no more than 12 inches apart)
6 Isolation valves	23 DHW connections — see water heater manual for piping
7 System circulator (see information above for wiring)	24 Strap system supply and return sensors to lines as shown, at least 6 pipe diameters (but no more than 3 feet) from boiler connection tees.
8 Diaphragm (or bladder) type expansion tank (see page 56 for piping of closed-type expansion tank, if used)	26 Temperature/Pressure gauge
9 Air separator [with automatic air vent only on systems using diaphragm (or bladder) type expansion tank]	27 DHW relief valve, if used
10 Flow/check valves	■ Items supplied with boiler
	■ Items supplied by others

Other piping alternatives

See page 14 and page 15 and ADVANCED INSTALLATION section for additional piping suggestions.



Using with Weil-McLain AQUA PLUS water heaters

See **AQUA PLUS** - Product Manual for typical water piping.

See **ADVANCED INSTALLATION** section for additional piping information and applications.

AQUA PLUS DHW installation — quick-selection

- NOTICE** The information in this section is for usage of Ultra boilers with Weil-McLain AQUA PLUS indirect water heaters.
- NOTICE** For dedicated DHW applications, use the circulator supplied with the boiler to circulate to the water heater as shown in this section.
- NOTICE** By default, the U-Control Module turns off space heating during DHW heating (if DHW input is priority 1). The boiler circulator will turn off, preventing hot water from circulating to the system (optional timeout setting can be used to override).
- CAUTION** DO NOT use a closed-type expansion tank on a system with a Weil-McLain AQUA PLUS water heater. The water heater must use an automatic air vent. Operation of the automatic air vent will deplete air in the piping, causing the expansion tank to waterlog. Always use a diaphragm- or bladder-type expansion tank with AQUA PLUS water heaters.

1. Follow the guidelines on this page and page 15 to connect the water heater to the boiler. Use Figure 8 for dedicated water heating-only applications. Use Figure 10 and Figure 9, page 15 for combined space heating/water heating applications.

Figure 8 Ultra boiler with Ultra PLUS or AQUA PLUS water heater — dedicated water heating application, typical piping schematic

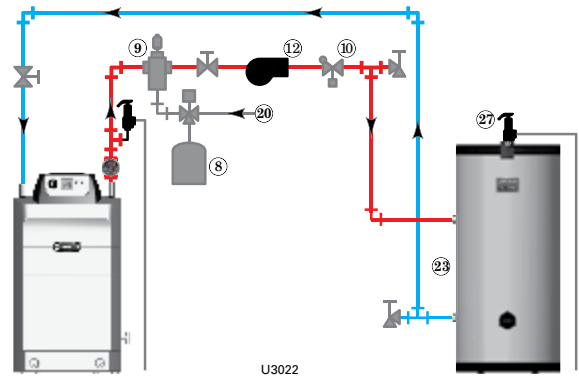

2. The AQUA PLUS water heater can also be installed as one of the zones in the system. This method, however, requires flow through the main system even during the summer (non-space heating) months. Piping as shown in Figure 10 and Figure 9, page 15 allows isolation of flow to just the water heater piping during non-heating periods.

Figure 7 Use the table below to size DHW loop piping and select a circulator (see **ADVANCED** section for other DHW tanks)

Boiler Ultra	Partial load (see Figure 10 and Figure 9, page 15) (combined space heating/water heating application)							Dedicated boiler (see Figure 8) (water heating only)						
	PLUS model	GPM	MBH 115/140	GPH 115/140	Head loss (ft)	DHW pipe size	CIRC	PLUS model	GPM	MBH 115/140	GPH 115/140	Head loss (ft)	DHW pipe size	CIRC
-80 (71 MBH)	40	6.5	71/71	160/124	8.5	1	007	40	6.5	71/71	160/124	8.5	1	007
	60	6.5	71/71	168/132	8.5	1	007	60	6.5	71/71	168/132	8.5	1	007
	80	6.5	71/71	176/140	8.5	1	007	80	6.5	71/71	176/140	8.5	1	007
-105 (94 MBH)	40	10.1	94/94	217/154	17.0	1¼	0014	40	6.4	94/86	203/141	8.6	1	007
	60	6.4	94/94	211/162	8.6	1	007	60	6.4	94/94	211/162	8.6	1	007
	80	6.4	94/94	219/170	8.6	1	007	80	6.4	94/94	219/170	8.6	1	007
-155 (139 MBH)	40	12.1	119/98	248/160	15.9	1¼	0014	40	12.1	119/98	248/160	15.9	1¼	0014
	60	12.1	139/120	295/220	15.9	1¼	0014	60	12.1	139/120	295/220	15.9	1¼	0014
	80	12.1	139/139	305/230	15.9	1¼	0014	80	12.1	139/139	305/230	15.9	1¼	0014
-230 (207 MBH)	40	13.5	120/100	251/162	15.2	1¼	0014	40	Not recommended — boiler capacity exceeds maximum output of water heater					
	60	18.4	169/128	350/207	23.7	1½	1400-20	60	Not recommended — boiler capacity exceeds maximum output of water heater					
	80	13.5	207/207	430/325	15.2	1¼	0014	80	13.5	207/207	430/325	15.2	1¼	0014
-299 (252 MBH)	40	13.1	120/100	250/162	9.7	1¼	0010	40	Not recommended — boiler capacity exceeds maximum output of water heater					
	60	19.3	170/129	351/208	11.7	1½	0014	60	Not recommended — boiler capacity exceeds maximum output of water heater					
	80	24.9	252/252	510/381	18.4	1½	1400-20	80	Not recommended — boiler capacity exceeds maximum output of water heater					
-399 (365 MBH)	40	13.1	120/100	250/162	9.7	1¼	0010	40	Not recommended — boiler capacity exceeds maximum output of water heater					
	60	19.3	170/129	351/208	11.7	1½	0014	60	Not recommended — boiler capacity exceeds maximum output of water heater					
	80	24.9	320/253	636/382	18.4	1½	1400-20	80	Not recommended — boiler capacity exceeds maximum output of water heater					



Using with Weil-McLain AQUA PLUS water heaters (cont.)

See **AQUA PLUS** - Product Manual for typical water piping.

Figure 10 Ultra boiler with Ultra PLUS or AQUA PLUS-40, -60 or -80 water heater, zone valve zoning, typical piping

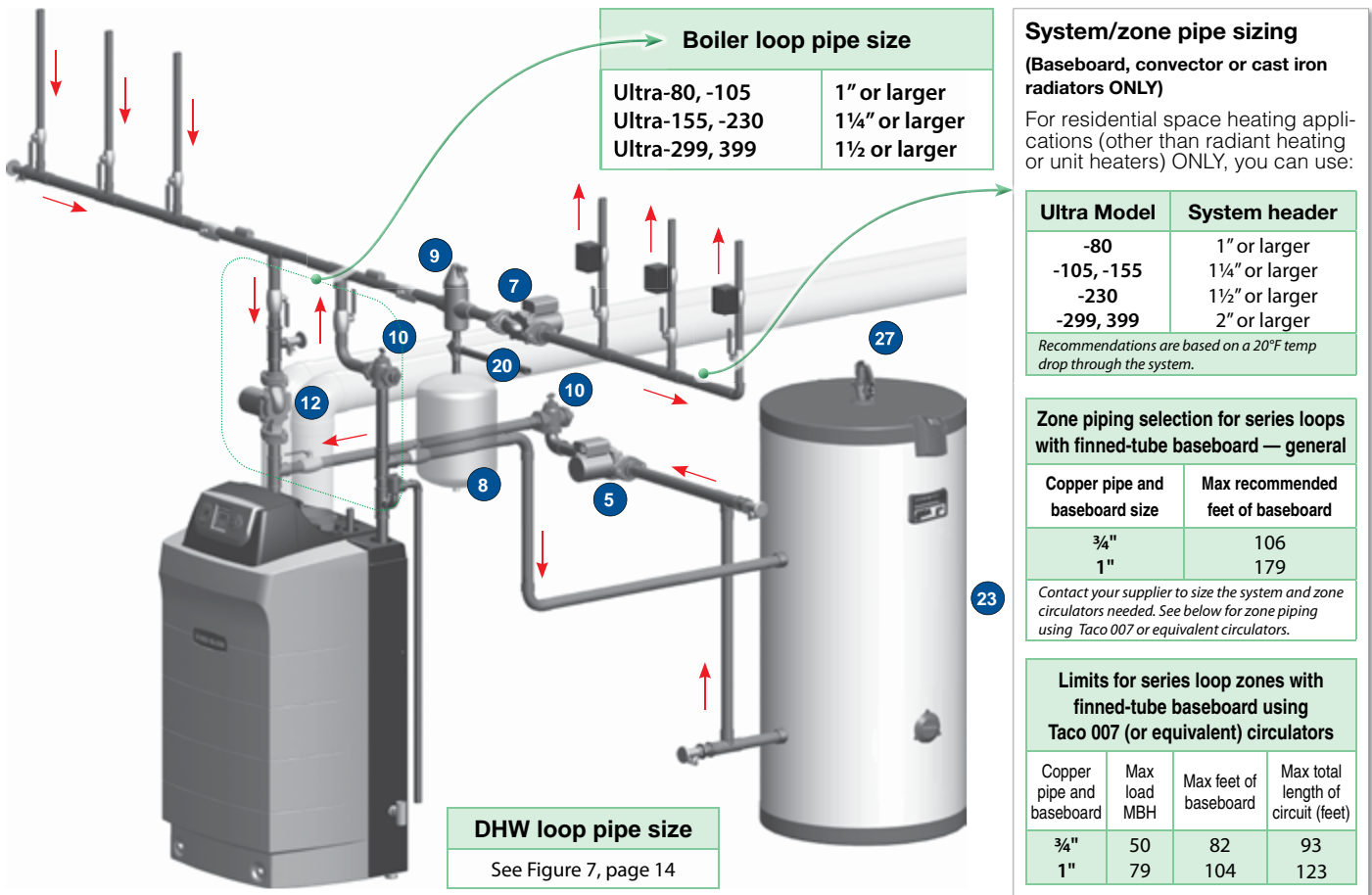
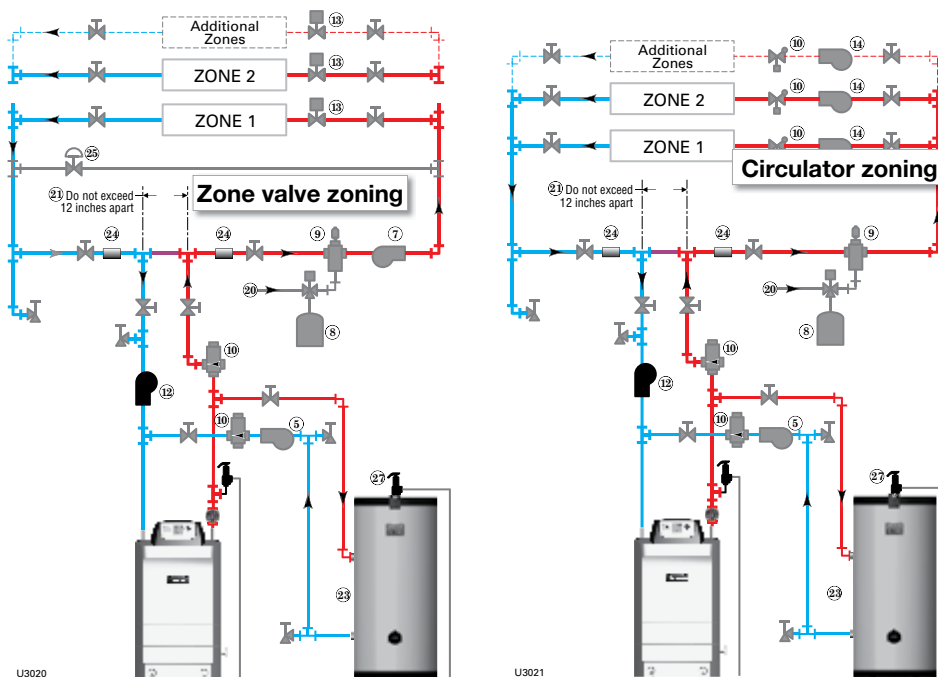

Figure 9 Ultra boiler with Ultra PLUS or AQUA PLUS water heater, typical piping schematics



Legend for Figure 10 and Figure 9

- 5 DHW circulator (see page 56 for suggested sizing)
 - 7 System circulator (provided by installer)
 - 8 Diaphragm type expansion tank ONLY — DO NOT use a closed-type tank with AQUA PLUS water heaters, because the automatic air vent will deplete the air from the system, causing the expansion tank to waterlog.
 - 9 Air separator with automatic air vent
 - 10 Flow/check valves
 - 12 Boiler circulator — provided with boiler
 - 13 Zone valves, typical
 - 20 Make-up water supply
 - 21 Primary/secondary connection
 - 23 DHW connections — see water heater manual for piping
 - 24 Strap system supply and return sensors to lines as shown, at least 6 pipe diameters (but no more than 3 feet) from boiler connection tees.
 - 25 Systems using high-head pumps may require a bypass pressure regulator to prevent damage to control valves.
 - 27 DHW relief valve must be installed in the tapping on top of the AQUA PLUS water heater.
- Items supplied with boiler
■ Items supplied by others



Venting/air piping — general

⚠ DANGER Do not install the Ultra boiler into a common vent with any other appliance. This will cause flue gas spillage or appliance malfunction, resulting in possible severe personal injury, death or substantial property damage.

⚠ WARNING Existing common vent systems may be too large for the appliances remaining connected after the existing boiler is removed.

⚠ WARNING Failure to follow all instructions can result in flue gas spillage and carbon monoxide emissions, causing severe personal injury or death.

When removing a boiler from an existing common vent system

The Ultra boiler cannot be common vented with any other appliance. When an existing boiler is replaced with an Ultra boiler, the Ultra boiler CANNOT use the existing common vent. The Ultra boiler requires its own vent and air piping, as specified in this manual. This may cause a problem for the appliances that remain on the old common vent, because the vent may be too large. The following test is intended to check for proper operation of the appliances remaining on the old common vent system.

Vent system verification

At the time of removal of an existing boiler, the following steps shall be followed with each appliance remaining connected to the common venting system placed in operation, while the other appliances remaining connected to the common venting system are not in operation. Seal any unused openings in the common venting system.

Existing vent test procedure

(The following is intended to test whether the appliances remaining on an existing vent system will operate satisfactorily.)

1. Visually inspect the venting system for proper size and horizontal pitch and determine there is no blockage or restriction, leakage, corrosion or other deficiencies which could cause an unsafe condition.
2. Test vent system — Insofar as is practical, close all building doors and windows and all doors between the space in which the appliances remaining connected to the common venting system are located and other spaces of the building. Turn on clothes dryers and any appliance not connected to the common venting system. Turn on any exhaust fans, such as range hoods and bathroom exhausts, so they will operate at maximum speed. Do not operate a summer exhaust fan. Close fireplace dampers.
3. Place in operation the appliance being inspected. Follow the lighting instructions. Adjust thermostat so appliance will operate continuously.
4. Test for spillage at draft hood relief opening after 5 minutes of main burner operation. Use the flame of a match or candle, or smoke from a cigarette, cigar, or pipe.
5. After it has been determined that each appliance remaining connected to the common venting system properly vents when tested as outlined herein, return doors, windows, exhaust fans, fireplace dampers, and any other gas-burning appliance to their previous conditions of use.

Any improper operation of common venting system should be corrected so the installation conforms with the National Fuel Gas Code, ANSI Z223.1 — latest edition. Correct by re-sizing to approach the minimum size as determined using the appropriate tables in Part 13 of that code. Canadian installations must comply with B149.1 or B149.2 Installation Code.

⚠ WARNING You must provide combustion air.

Direct vent — Install air inlet piping for the Ultra boiler as described in the Boiler manual and this addendum. The air termination fitting must be installed with the clearances and geometry relative to the vent outlet depicted in this manual to ensure that flue products do not enter the air intake.

Direct exhaust — Provide combustion air openings to boiler room/building as specified in this addendum and as required by all applicable codes.

Ensure that the combustion air will not contain any of the contaminants in Figure 11. DO NOT place combustion air supply opening or intake near a swimming pool, for example. Avoid areas subject to exhaust fumes from laundry facilities. These areas will always contain contaminants.

Contaminated combustion air will damage the boiler, resulting in possible severe personal injury, death or substantial property damage.

Figure 11 Corrosive contaminants and sources

Products to avoid
Spray cans containing chloro/fluorocarbons
Permanent wave solutions
Chlorinated waxes/cleaners
Chlorine-based swimming pool chemicals
Calcium chloride used for thawing
Sodium chloride used for water softening
Refrigerant leaks
Paint or varnish removers
Hydrochloric acid/muriatic acid
Cements and glues
Antistatic fabric softeners used in clothes dryers
Chlorine-type bleaches, detergents, and cleaning solvents found in household laundry rooms
Adhesives used to fasten building products and other similar products
Excessive dust and dirt
Areas likely to have contaminants
Dry cleaning/laundry areas and establishments
Swimming pools
Metal fabrication plants
Beauty shops
Refrigeration repair shops
Photo processing plants
Auto body shops
Plastic manufacturing plants
Furniture refinishing areas and establishments
New building construction
Remodeling areas
Garages with workshops
Buildings under construction (where air is contaminated with particulates)

Venting/air piping — general *(continued)*

⚠ DANGER Ultra Boilers must be vented and supplied with combustion and ventilation air using piping and methods described in this manual.

Every boiler must have its own vent. DO NOT common vent with any other appliance. See page 16.

Inspect finished vent and air piping thoroughly to ensure all are airtight and comply with the instructions provided and with all requirements of applicable codes.

Failure to provide a properly-installed vent and air system will cause severe personal injury or death.

⚠ WARNING Venting/combustion air piping - Installations must provide provisions for combustion and ventilation air in accordance with the section “Air for Combustion and Ventilation,” of the National Fuel Gas Code - ANSI Z223.1/NFPA54 – latest edition, or Sections 8.2, 8.3, or 8.4 of Natural Gas and Propane Installation Code - CAN/CSA B149.1, or applicable provisions of the local building codes.

⚠ WARNING Use only the materials listed in this manual for vent and air pipe and fittings. Failure to comply could result in severe personal injury, death or substantial property damage.

⚠ WARNING If used, a masonry chimney can ONLY be used as a PIPE CHASE for vent and air pipes — The vent and air piping must be installed as instructed in this manual and all joints must be sealed. The chimney must be used only for Ultra boilers. NO OTHER appliance or fire-place can be connected to the chimney.

The chimney must be straight, with no offsets, and the vent and air piping materials must comply with this instruction manual.

The chimney must be fitted with a sealed access opening, through which the interior of the chimney can be inspected.

The chimney and liner must be inspected at least once annually to verify condition.

Failure to comply could result in severe personal injury, death or substantial property damage.

Combustion air piping

1. Combustion air must be piped from outside to the boiler, following the instructions in this manual, and compliant with all applicable codes. Read the warning in Figure 11, page 16, and ensure the air intake will not be likely to draw in contaminated air.
2. Combustion air can be piped individually for each boiler, or it can be manifolded as shown in Figure 59, page 59. Air piping must always terminate on the same side (or roof) of the building as the vent.

Vent piping

1. Boiler flue gases must be piped from the boiler to outside, following the instructions in this manual, and compliant with all applicable codes. The vent pipe must terminate either through the sidewall or through the roof, located with the correct separation from the air termination. See Figure 14, page 18, and the associated instructions referenced.
2. Each Ultra boiler requires a separate vent. Do not common vent.

Vent and air piping materials

1. See Figure 13, page 19 for approved vent and air piping materials.



Venting & air — general *(cont.)*

Figure 12 Vent and air pipe options and maximum allowable piping lengths

Ultra model	Vent or air pipe size	• Maximum equivalent feet of piping • Number of elbows allowed at these lengths <i>(All applications include allowance for the terminations.)</i>											
		Direct vent Sidewall with Weil-McLain vent/air cap		Direct vent Sidewall with separate pipes — or — Direct exhaust (sidewall or vertical)		3" Concentric Sidewall or Vertical DO NOT use CPVC or ABS [Note 1]		4" Concentric Sidewall or Vertical DO NOT use CPVC or ABS [Note 1]		Direct vent Vertical with separate pipes		Direct vent Vertical exhaust Sidewall air	
		Direct vent only		Direct vent or Direct exhaust		Direct vent only		Direct vent only		Direct vent only		Direct vent only	
		Length	Ells	Length	Ells	Length	Ells	Length	Ells	Length	Ells	Length	Ells
-80/105	2"*	100 (ab)	2	100 (a)	2	100 (ab)	1	NA		100 (a)	1	100 (a)	1
	3"	100	2	100	2	100	1	NA		100	1	100	1
-155	3"	100	2	100	2	100	1	NA		100	1	100	1
-230	3"	30 (c)	2	30 (c)	2	30 (c)	1	30 (c)(d)	1	30 (c)	1	30 (c)	1
	4"	100 (d)	2	100	2	70 (d)	1	100	1	100	1	100	1
-299	4"	100	2	100	2	70 (d)	1	100	1	100	1	100	1
-399	4"	100	2	100	2	NA		100	1	100	1	100	1
Note 1:	IPEX 3" and 4" PVC concentric vent kits can be used with standard PVC pipe, fittings and cement (ANSI/ASTM D1785) except where ULC S636 compliance is required. For ULC S636 compliance, all pipe, fittings and cement must be IPEX System 636. When using IPEX kits, use only IPEX product code 196006 for 3" venting or IPEX product code 196021 for 4" venting. Contact Weil-McLain for ordering information and availability of Weil-McLain venting kits.												
	Polypropylene - Separate pipe and concentric termination by respective manufacturers.												
Additional notes	a — Use 3"x2" reducer at boiler b — Use 3"x2" reducers at termination						c — Use 4"x3" reducer at boiler d — Use 4"x3" reducers at termination						
	* Ultra-80 and 105 boilers installed with 2-inch vent piping automatically derate due to the pressure loss in the vent and air piping. The derate ranges up to 10% for the Ultra-80 at 100 feet or 15% for the Ultra-105 at 100 feet.												
Equivalent feet for elbows — deduct from maximum equivalent length of piping: PVC • 7 feet per for each 4-inch elbow & 2 or 3-inch 90° long-radius or 45° elbow • 16 feet for each 2- or 3-inch short-radius elbow PP • Centrotherm 3" = 6' 4" = 20' Duravent 3" = 17' 4" = 22'							Stainless steel (AL29-4C) vent pipe install an adapter at the boiler for all applications. Also install an adapter at the termination unless using separate-pipe termination.						



Venting & air — general *(cont.)*

Figure 13 Vent and air piping materials — Use only the materials listed below, ensuring that all materials meet local codes

Item	Material	Standards for installations in:	
		United States	Canada
Plastic piping materials			
Vent or air pipe & fittings	PVC schedule 40	ANSI/ASTM D1785	Plastic vent pipe must be certified to ULC S636 when required. (Note 2)
	PVC-DWV (Note 1)	ANSI/ASTM D2665	
	CPVC schedule 40 (Note 1)	ANSI/ASTM F441	
	ABS-DWV schedule 40 (Note 1)	ANSI/ASTM D2661	
PVC & ABS pipe cement & primer	PVC	ANSI/ASTM D2564	Air pipe can be any of those listed at left if acceptable for local codes.
	CPVC (Note 1)	ANSI/ASTM F493	
	ABS (Note 1)	ANSI/ASTM D2235	
Polypropylene vent pipe, fittings, terminations	Simpson-Duravent — Obtain all materials from M&G Simpson-Duravent Centrotherm Eco Systems InnoFlue® Single-wall — Obtain all materials from Centrotherm	See manufacturer's literature for detailed information MUST USE LOCKING COLLAR ON EVERY JOINT	ULC S636
AL29-4C piping materials			
Vent pipe AL29-4C stainless steel	Heat Fab, Inc. — Saf-T-Vent® Z-Flex, Inc. — Z-Vent II Simpson Dura-Vent — FasNSeal™	Certified for Category IV and direct vent appliance venting	Certified for Category IV and direct vent appliance venting
Weil-McLain bird screens <i>(purchase separately)</i>			
Weil-McLain bird screens	For 2" or 3" vent or air termination (cut to size if necessary) 3" vent screen: W-M part number 383-500-105	For 3" or 4" vent or air termination (cut to size if necessary) 4" vent screen: W-M part number 383-500-110	
Note 1:	DO NOT use DWV, CPVC or ABS when using concentric vent termination. Use ONLY PVC schedule 40.		
Note 2:	IPEX PVC concentric terminations utilize PVC pipe/fittings certified to ULC S636. Where ULC S636 compliance is required, use only IPEX System 636 pipe, fittings and cement.		
⚠WARNING	AL29-4C vent piping — Install a PVC-to-stainless adapter supplied by the vent pipe manufacturer at the boiler vent connection and at the termination (when using Weil-McLain plate or concentric PVC termination). DO NOT mix piping from different vent pipe manufacturers unless using adapters specifically designed for the purpose by the manufacturer.		
⚠WARNING	Plastic piping — Do not attempt to connect different types of plastic piping together.		
⚠WARNING	DO NOT use cellular core pipe.		
⚠WARNING	All vent and air pipes require a bird screen at each termination where specified in the manual or vent supplement. Purchase bird screens separately from Weil-McLain or vent kit supplier. Note that most kits do not include the screens.		



Sidewall vent/air termination: *Separate pipes*

Allowable vent/air pipe materials

1. Use only the materials listed in Figure 13, page 19.
2. The Weil-McLain vent termination kit includes inside and outside wall plates, bird screens, and mounting hardware to secure the plates (kit included with boiler).

Maximum piping length

1. Locate the terminations such that the total air piping and vent piping from the boiler to the termination will not exceed the maximum length given in Figure 14.
2. Maximum lengths listed in Figure 14 allow for 2 elbows. Additional elbows required a reduction in maximum length as explained in the table notes.

Connecting from termination to boiler

1. Install the terminations as instructed in the following. Then proceed to page 82 to complete the air and vent piping between the termination and the boiler.

Determine location — separate elbows

⚠WARNING A gas vent extending through an exterior wall shall not terminate adjacent to the wall or below building extensions such as eaves, parapets, balconies or decks. Failure to comply could result in severe personal injury, death or substantial property damage.

1. Locate the vent/air terminations using the following guidelines.
2. The air piping must terminate in a down-turned elbow as shown in Figure 15. This arrangement avoids recirculation of flue products into the combustion air stream.
 - a. Apply the configuration on the left side of Figure 15 unless the terminations would fail to meet minimum clearance to grade or snow line.
 - b. Apply the configuration on the right side of Figure 15 when the terminations need to be raised higher to meet clearance to grade or snow line.
 - c. The vent and air pipes may run up as high as 4 feet, as shown in Figure 15 right side with no enclosure. The vent and air pipes must be secured with braces, and all clearances and lengths must be maintained. Space braces no further than 24 inches apart. (See WARNING below for extremely cold climates.)
 - d. External venting greater than 4 feet requires an insulated enclosure around the vent and air pipes. The vent and air terminations must exit through the enclosure as shown in Figure 15, maintaining all required clearances.
3. The vent piping must terminate in an elbow pointed outward or away from the air inlet, as shown in Figure 15.

⚠WARNING Do not exceed the maximum lengths of the outside vent piping shown in Figure 15. Excessive length exposed to the outside could cause freezing of condensate in the vent pipe, resulting in potential boiler shutdown. In extremely cold climates, install an insulated chase around the vent piping, particularly when using longer lengths. The chase must allow for inspection of the vent pipe, and insulation must be protected from water.

Figure 14 Maximum piping lengths for separate vent and air pipe sidewall termination

Boiler Ultra	Maximum Piping, 2" *		Maximum Piping, 3" *		Maximum Piping, 4" *	
	Feet	Elbows	Feet	Elbows	Feet	Elbows
-80 **	100	2	100	2	Not allowed	
-105 **	100	2	100	2		
-155	Not allowed		100	2		
-230	Not allowed		30	2	100	2
-299	Not allowed		Not allowed		100	2
-399	Not allowed		Not allowed		100	2

* Install pipe reducers to adapt from pipe size used to the outside diameter required at the boiler. You do not have to reduce allowable pipe length for the reducers.

** Ultra-80 and 105 boilers installed with 2-inch vent piping automatically derate due to the pressure loss in the vent and air piping. The derate ranges up to 10% for the Ultra-80 at 100 feet or 15% for the Ultra-105 at 100 feet.

For piping using more than 2 elbows, reduce maximum allowable length:

- 7 feet for each additional 4-inch elbow (90° or 45°)
- 7 feet for each additional 2 or 3-inch long radius elbow
- 16 feet for each 2 or 3-inch short radius elbow
- 7 feet for each 2 or 3-inch 45-degree elbow.

Figure 15 Sidewall termination — separate pipes — configuration options and minimum clearances from vent to air terminations

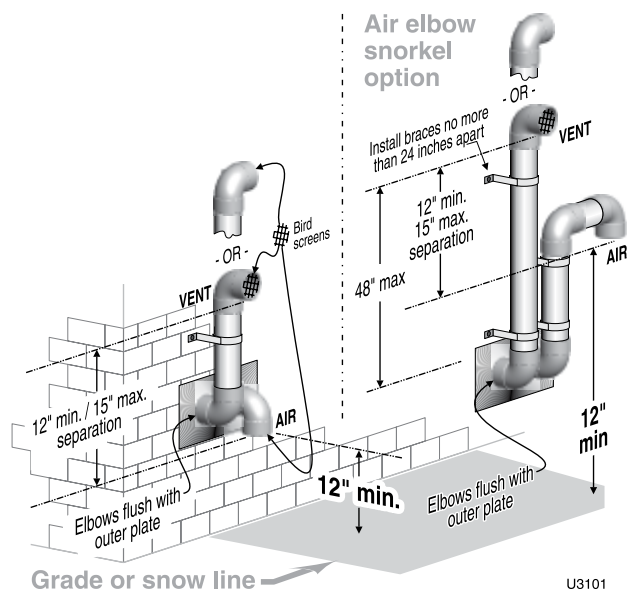

U3101

Sidewall vent/air termination: *Separate pipes* (continued)

4. You must consider the surroundings when terminating the vent and air:
 - a. Position the vent termination where vapors will not damage nearby shrubs, plants or air conditioning equipment or be objectionable.
 - b. The flue products will form a noticeable plume as they condense in cold air. Avoid areas where the plume could obstruct window views.
 - c. Prevailing winds could cause freezing of condensate and water/ice buildup where flue products impinge on building surfaces or plants.
 - d. Avoid possibility of accidental contact of flue products with people or pets.
 - e. Do not locate the terminations where wind eddies could affect performance or cause recirculation, such as inside building corners, near adjacent buildings or surfaces, window wells, stairwells, alcoves, courtyards or other recessed areas.
 - f. Do not terminate above any door or window or under a deck. Condensate can freeze, causing ice formations.
 - g. Locate or guard vent to prevent condensate damage to exterior finishes.
5. Maintain clearances as shown in the illustrations in this manual section. Also maintain the following:
 - a. Vent must terminate:
 - At least 6 feet from adjacent walls.
 - No closer than 5 feet below roof overhang.
 - At least 7 feet above any public walkway.
 - At least 3 feet above any forced air intake within 10 feet.
 - No closer than 12 inches below or horizontally from any door or window or any other gravity air inlet.
 - b. Do not terminate closer to 4 feet horizontally from any electric meter, gas meter, regulator, relief valve or other equipment. Never terminate above or below any of these within 4 feet horizontally.
6. Locate terminations so they are not likely to be damaged by foreign objects, such as stones or balls, or subject to buildup of leaves or sediment.
7. Do not connect any other appliance to the vent pipe or multiple boilers to a common vent pipe.

Completing the vent/air piping

1. Install vent/air penetrations as explained in the following pages before installing vent and air piping from the boiler to the terminations. Insert piping from boiler air and vent connections, then attach exterior termination piping.
2. Follow instructions beginning on page 71 to complete piping from boiler to termination.

Figure 16 Sidewall termination with separate pipes — clearances to openings

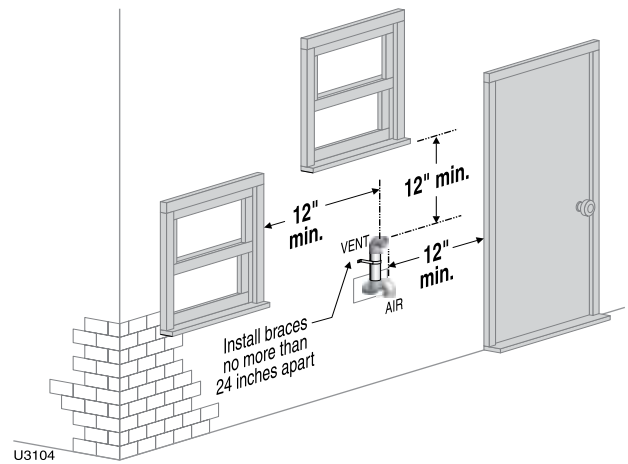

Figure 17 Sidewall termination with separate pipes — clearances to public walkway or forced air intake

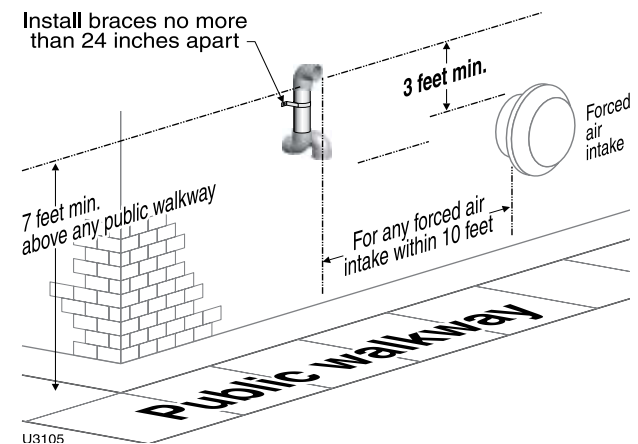
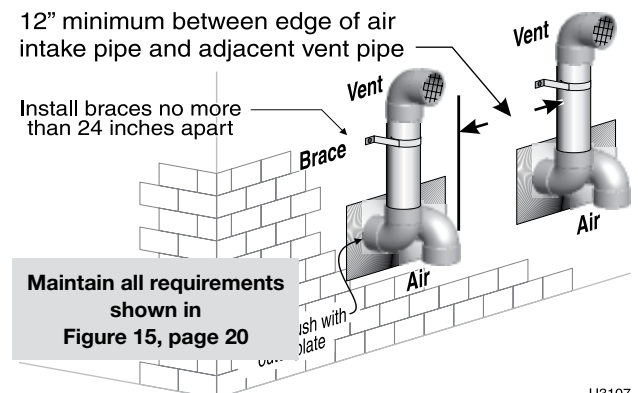

Figure 18 Multiple terminations — separate pipes — clearance from vent of one to air intake of the next





Sidewall vent/air termination: *Separate pipes* (continued)

Multiple vent/air terminations

1. When terminating multiple Ultra boilers, terminate each vent/air connection as described in this manual.

▲WARNING All vent pipes and air inlets must terminate at the same height to avoid possibility of severe personal injury, death or substantial property damage.

2. Place wall penetrations to obtain minimum clearance of 12 inches between vent pipe and adjacent air inlet elbow, as shown in Figure 18, page 21 for U. S. installations.
3. For Canadian installations, provide clearances required by Natural Gas and Propane Installation CAN/CSA B149.1 or B149.2 Installation Code.
4. The air inlet of an Ultra boiler is part of a direct vent connection. It is not classified as a forced air intake with regard to spacing from adjacent boiler vents.
5. Combustion air (NOT vent piping) can be manifolded as shown in Figure 59, page 59.

Prepare wall penetrations

1. Air pipe penetration:
 - a. Cut a hole for the air pipe. Size the air pipe hole as close as desired to the air pipe outside diameter.
2. Vent pipe penetration:
 - a. Cut a hole for the vent pipe. For either combustible or noncombustible construction, size the vent pipe hole at least 0.4" larger than the vent pipe diameter:
 - 2¾" hole for 2"
 - 4" hole for 3"
 - 5" hole for 4"
 - b. Insert a galvanized metal thimble in the vent pipe hole as shown in Figure 20.
3. Use a sidewall termination plate as a template for correct location of hole centers. Sidewall termination plates must be purchased separately. See the parts list at the end of this manual for part numbers.
4. Follow all local codes for isolation of vent pipe when passing through floors or walls.
5. Seal exterior openings thoroughly with exterior caulk.

Termination and fittings

1. Prepare the vent termination elbow and the air termination elbow (Figure 20) by inserting bird screens. Bird screens must be purchased separately. See the parts list at the end of this manual for part numbers.
2. When completed, the air termination coupling must be oriented at least 12 inches below the vent termination and at least 12 inches above grade or snow line as shown in Figure 15, page 20.
3. You can orient the vent termination elbow either directly outward or 90 degrees away from the air inlet elbow as shown in Figure 15, page 20.
4. Maintain the required dimensions of the finished termination piping as shown in Figure 15, page 20.
5. Do not extend exposed vent pipe outside of building more than shown in this document. Condensate could freeze and block vent pipe.

NOTICE If extending the vent and air pipes out from the wall, install a coupling on each pipe. Mount the piping with the coupling flush with the outer plate.

Figure 19 Multiple terminations — separate pipes — clearance from vent of one to air intake of the next — alternate configuration of air and vent terminations

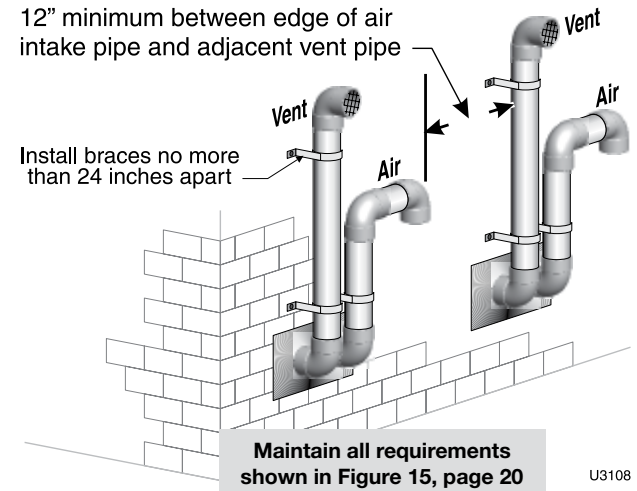
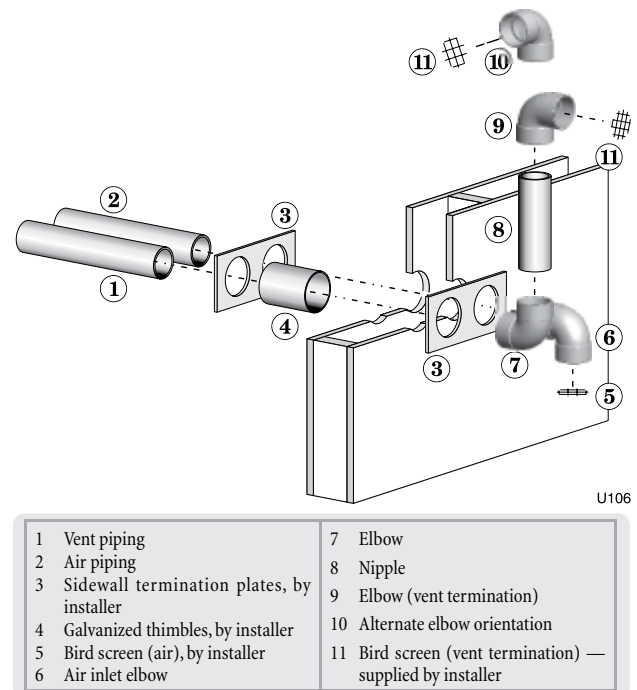

Figure 20 Sidewall termination assembly — using separate pipes





Vertical vent/air termination: *Separate pipes*

Allowable vent/air pipe materials

1. Use only the materials listed in Figure 13, page 19.
2. Purchase bird screens for vent and air terminations separately. See the parts list at the end of this manual.

Maximum piping length

1. Locate the terminations such that the total air piping and vent piping from the boiler to the termination will not exceed the maximum length given in Figure 21.
2. Maximum lengths listed in Figure 21 allow for 1 elbow. Additional elbows required a reduction in maximum length as explained in the table notes.

Connecting from termination to boiler

1. Install the termination penetrations as instructed in the following. Then proceed to page 82 to complete the piping between the termination and the boiler.

Determine location

1. Locate the vent/air terminations using the following guidelines:
2. The air piping must terminate in a down-turned 180-degree return bend as shown in Figure 22. The edge of the air inlet elbow must be at least 12 inches above the roof or snow line.
3. The vent piping must terminate in an up-turned coupling as shown in Figure 22. The top of the coupling must be at least 12 inches above the air intake in order to avoid recirculation of flue products into the combustion air stream.
4. You must consider the surroundings when terminating the vent and air:
 - a. Position the vent termination where vapors will not damage nearby shrubs, plants or air conditioning equipment or be objectionable.
 - b. The flue products will form a noticeable plume as they condense in cold air. Avoid areas where the plume could obstruct window views.
 - c. Prevailing winds could cause freezing of condensate and water/ice buildup where flue products impinge on building surfaces or plants.
 - d. Avoid possibility of accidental contact of flue products with people or pets.
 - e. Do not locate the terminations where wind eddies could affect performance or cause recirculation, such as inside building corners, near adjacent buildings or surfaces, window wells, stairwells, alcoves, courtyards or other recessed areas.
 - f. Do not terminate above any door or window. Condensate can freeze, causing ice formations.
 - g. Locate or guard vent to prevent condensate damage to exterior finishes.

Figure 21 Maximum piping lengths for separate vent and air pipe vertical termination

Boiler Ultra	Maximum Piping, 2" *		Maximum Piping, 3" *		Maximum Piping, 4" *	
	Feet	Elbows	Feet	Elbows	Feet	Elbows
-80	30	1	100	1	Not allowed	
-105	30	1	100	1		
-155	Not allowed		100	1		
-230	Not allowed		30	1	100	1
-299	Not allowed		Not allowed		100	1
-399	Not allowed		Not allowed		100	1

* Install reducers as necessary where connecting to the boiler vent and air connections.

For piping using more than 1 elbow, reduce maximum allowable length:

- 7 feet for each additional 4-inch elbow (90° or 45°)
- 7 feet for each additional 2 or 3-inch long radius elbow
- 16 feet for each 2 or 3-inch short radius elbow
- 7 feet for each 2 or 3-inch 45-degree elbow.

NOTE: The 180-degree return bend is included in the allowed fittings. No deduction is required.

Figure 22 Vertical termination — separate pipes

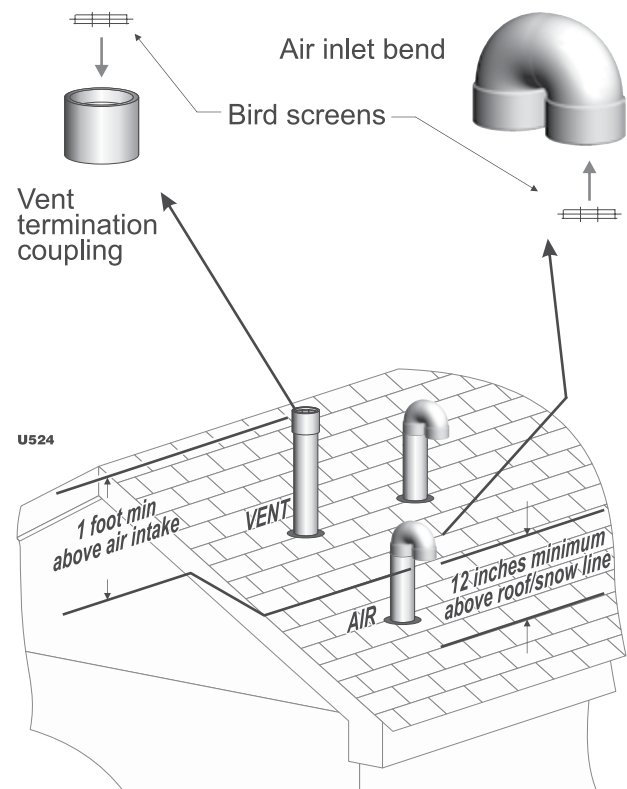

Vertical vent/air termination: *Separate pipes* (continued)

5. Maintain clearances to vent termination as given below:
 - a. Vent must terminate:
 - At least 6 feet from adjacent walls.
 - No closer than 5 feet below roof overhang.
 - At least 7 feet above any public walkway.
 - At least 3 feet above any forced air intake within 10 feet.
 - No closer than 12 inches below or horizontally from any door or window or any other gravity air inlet.
 - b. Air inlet must terminate at least 12 inches above the roof or snow line and at least 12 inches below the vent termination as shown in Figure 22, page 23.
 - c. Do not terminate closer to 4 feet horizontally from any electric meter, gas meter, regulator, relief valve or other equipment. Never terminate above or below any of these within 4 feet horizontally.
6. Locate terminations so they are not likely to be damaged by foreign objects, such as stones or balls, or subject to buildup of leaves or sediment.
7. Do not connect any other appliance to the vent pipe or multiple boilers to a common vent pipe.

Prepare roof penetrations

1. Air pipe penetration:
 - a. Cut a hole for the air pipe. Size the air pipe hole as close as desired to the air pipe outside diameter.
2. Vent pipe penetration:
 - a. Cut a hole for the vent pipe. For either combustible or noncombustible construction, size the vent pipe hole at least 0.4" larger than the vent pipe diameter:
 - 2¾" hole for 2"
 - 4" hole for 3"
 - 5" hole for 4"
 - b. Insert a galvanized metal thimble in the vent pipe hole.
3. Space the air and vent holes to provide the minimum spacings shown in Figure 22, page 23.
4. Follow all local codes for isolation of vent pipe when passing through floors, ceilings and roofs.
5. Provide flashing and sealing boots sized for the vent pipe and air pipe.

Termination and fittings

1. Prepare the vent termination elbow and the air termination elbow (Figure 22, page 23) by inserting bird screens. Bird screens must be purchased separately. See the parts list at the end of this manual for part numbers.
 - a. If using 3-inch piping for an Ultra-230, cut a 4-inch bird screen by placing 3-inch fitting on screen and cutting around it as a template.
2. The air piping must terminate in a down-turned 180-degree return bend as shown in Figure 22, page 23. The edge of the air intake elbow must be at least 12 inches above the roof or snow line.

Figure 23 Termination location — separate pipes — terminations for multiple boilers

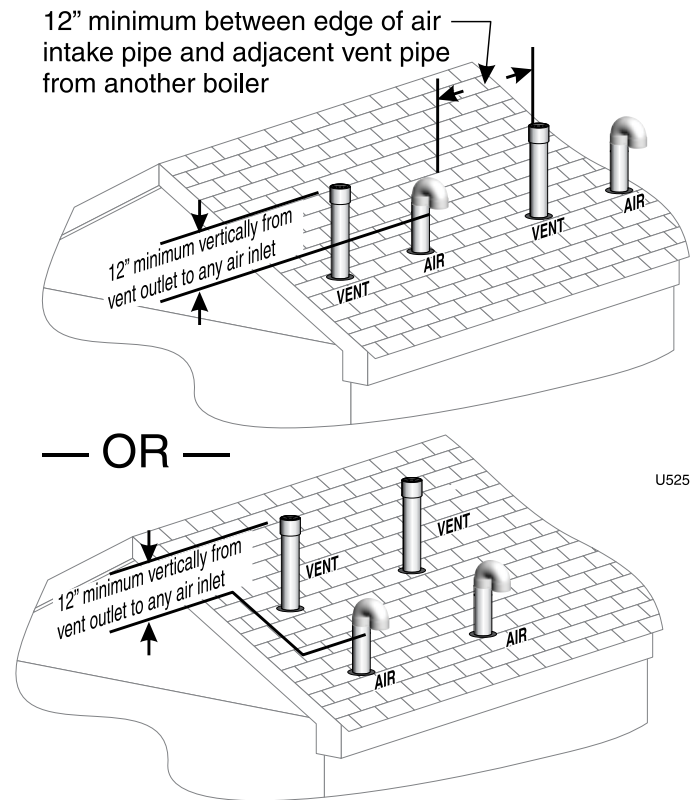

3. The vent piping must terminate in an up-turned coupling as shown in Figure 22, page 23 in order to avoid recirculation of flue products into the combustion air stream.
4. Maintain the required dimensions of the finished termination piping as shown in Figure 22, page 23.
5. Do not extend exposed vent pipe outside of building more than shown in this document. Condensate could freeze and block vent pipe.

Multiple vent/air terminations (Figure 23)

1. When terminating multiple Ultra boilers, terminate each vent/air connection as described in this section.

WARNING Terminate all vent pipes at the same height and all air pipes at the same height to avoid possibility of severe personal injury, death or substantial property damage.

2. Place roof penetrations to obtain minimum clearance of 12 inches between edge of air intake elbow and adjacent vent pipe of another boiler for U. S. installations (see Figure 2). For Canadian installations, provide clearances required by Natural Gas and Propane Installation CAN/CSA B149.1 or B149.2 Installation Code.
3. The air inlet of an Ultra boiler is part of a direct vent connection. It is not classified as a forced air intake with regard to spacing from adjacent boiler vents.



DIRECT VENT

Figure 24 **DIRECT VENT APPLICATIONS** — Vent and air termination options

DIRECT VENT SIDEWALL termination		DIRECT VENT VERTICAL termination		DIRECT VENT VERTICAL vent and SIDEWALL air	
<p>Weil-McLain sidewall termination plate</p> <p>(See Boiler manual page 67)</p>		<p>3" or 4" concentric termination</p> <p>(See Boiler manual page 72)</p>		<p>Vertical vent termination and Sidewall air termination</p> <p>(See Boiler manual page 79)</p>	
<p>3" or 4" concentric termination</p> <p>(See Boiler manual page 72)</p>			<p>Vertical termination with separate vent and air pipes</p> <p>(See Boiler manual page 73)</p>		
<p>Sidewall termination with separate vent and air pipes</p> <p>(See Boiler manual page 66)</p>					

<p>Direct vent installation sequence</p>	<p>Step 1 Install the boiler.</p> <p>Step 2 Determine the termination method — sidewall or vertical, concentric or separate pipes, etc.</p> <p>Step 3 Determine proper location for wall or roof penetration for each termination.</p> <p>Step 4 Install termination assembly as described in this manual.</p> <p>Step 5 Install air and vent piping from boiler to termination.</p> <p>Step 6 Install pipe supports and brackets as required.</p>
---	--

BASIC INSTALLATION

DIRECT EXHAUST

Figure 25 **DIRECT EXHAUST APPLICATIONS** — Vent termination options (combustion air from room)

DIRECT EXHAUST Sidewall termination		DIRECT EXHAUST Vertical termination	
<p>Sidewall vent termination</p> <p>(See Boiler manual page 83)</p>	<p style="text-align: right; font-size: small;">U5509E-4w</p>	<p>Vertical vent termination</p> <p>(See Boiler manual page 83)</p>	<p style="text-align: right; font-size: small;">U5509E-4w</p>
<p>Direct exhaust installation sequence</p>	<p>Step 1 Install the boiler.</p> <p>Step 2 Determine the proper location for roof or wall penetration for each termination.</p> <ul style="list-style-type: none"> • Prepare roof penetrations before installing vent piping. • Finish by attaching external pipe and fittings as shown in the termination instructions. • Vertical terminations only — Install terminations as described in this addendum. • Support vertical runs on the outside of the building with brackets as shown in the termination instructions. <p>Step 3 Install vent piping from boiler to termination.</p> <ul style="list-style-type: none"> • Install a hanger support within 6 inches of any upturn in the piping. • Slope horizontal piping downward toward the boiler at least 1/4 inch per foot. <p>Step 4 Connect the vent piping at the boiler per manual instructions.</p>		

Install condensate line

Prepare condensate fittings

1. Remove PVC fittings and gasket from the accessories bag.
2. Deburr and chamfer outside and inside of ½" x 1¼" PVC nipple to ensure even cement distribution when joining.
3. Clean nipple ends and all fittings. Dry thoroughly.
4. For each joint in the condensate line, apply the following. Assemble parts ONLY in the order given.
 - a. Apply primer liberally to both joint surfaces — pipe end and fitting socket.
 - b. While primer is still damp, lightly apply approved cement to both surfaces in a uniform coating.
 - c. Apply a second coat of cement to both surfaces. Avoid using too much cement on sockets to prevent cement buildup inside.
 - d. With cement still wet, insert pipe into fitting, twisting ¼ turn. Make sure pipe is fully inserted.
 - e. Wipe excess cement from joint. Check joint to be sure a smooth bead of cement shows around the entire joint.
5. See Figure 26.
6. Assemble the ½" PVC nipple to the PVC reducing elbow as shown.
7. Allow joint to dry completely.
8. Then slide gasket over nipple as shown in Figure 27.
9. Slide nipple through jacket condensate line hole to position as shown in Figure 27.
10. Cement the ½" tee to the protruding ½" nipple. Be sure both nipple and reducing elbow finish upright.

CAUTION Firmly press the reducing elbow and the tee together while the cement sets to ensure the gasket is securely compressed. The gasket ensures the jacket enclosure is airtight at this location.

Connect condensate trap line and fittings

1. Remove condensate trap line from bag.
2. Ultra-80 & -105 only — Figure 28
 - a. Guide the condensate trap line through the bracket hole as shown.
 - b. Place a hose clamp over the end of the condensate line.
 - c. Then slide the end of the trap line over the heat exchanger condensate connection.
 - d. Tighten the hose clamp to secure the trap line.
 - e. Place a hose clamp over the other end of the condensate trap line.
 - f. Slide the trap line over the reducing elbow and secure with the hose clamp.
3. Ultra-155 and larger — Figure 30, page 28 or Figure 31, page 28
 - a. Slide a hose clamp over each end of the condensate trap line.
 - b. Slide the trap line onto the heat exchanger condensate connection and PVC reducing elbow as shown.
 - c. Tighten the hose clamps to secure the trap line.

Figure 26 Condensate trap assembly

PVC reducing elbow

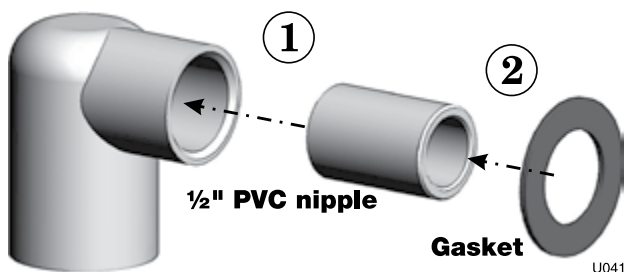

Figure 27 Condensate trap assembly into jacket

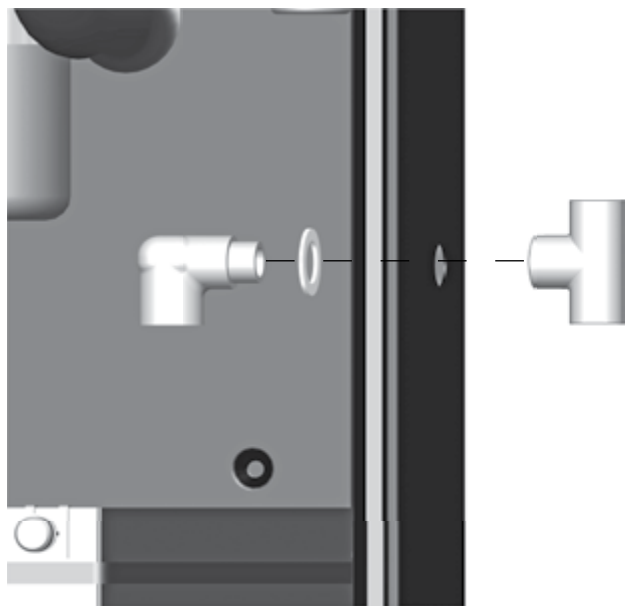
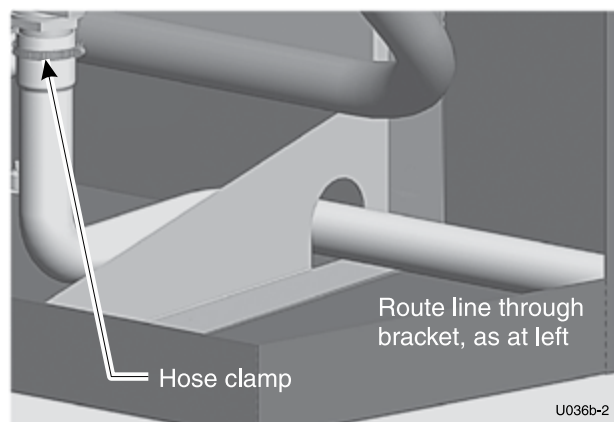

Figure 28 Condensate drain — Ultra-80 & -105





Install condensate line *(continued)*

Condensate drain tubing

1. Connect condensate drain tubing to the 1/2" PVC tee and run to floor drain or condensate pump (see Figure 32). Use 1/2" PVC or CPVC pipe; or 5/8" I. D. tubing.

NOTICE Use materials approved by the authority having jurisdiction. In the absence of other authority, PVC and CPVC pipe must comply with ASTM D1785, F441 or D2665. Cement and primer must comply with ASTM D2564, F656, or F493. For Canada, use CSA or ULC certified PVC or CPVC pipe, fittings and cement.

2. Leave the top of the 1/2" tee OPEN. This is needed as a vacuum break.
3. When installing a condensate pump, select one approved for use with condensing boilers and furnaces. The pump should have an overflow switch to prevent property damage from condensate spillage. See Figure 29 for required flow capacity.
4. When sizing condensate pumps, make sure to include the total load of all Ultra boilers connected to it.

CAUTION The condensate line must remain unobstructed, allowing free flow of condensate. If condensate is allowed to freeze in the line or if the line is obstructed in any other manor, condensate can exit from the boiler tee, resulting in potential water damage to property.

NOTICE Condensate from the Ultra boiler will be slightly acidic (typically with a pH from 3.2 to 4.5). Install a neutralizing filter if required by local codes. See Replacement parts section at the end of this manual for the Weil-McLain kit.

Figure 29 Suggested condensate pump capacity, GPH

Boiler	Minimum recommended condensate pump capacity, per boiler, GPH		
Ultra-80	2	Ultra-230	6
Ultra-105	3	Ultra-299	8
Ultra-155	4	Ultra-399	8

Figure 30 Condensate drain — Ultra-155 & -230 (PVC tee installation shown applies to all models)

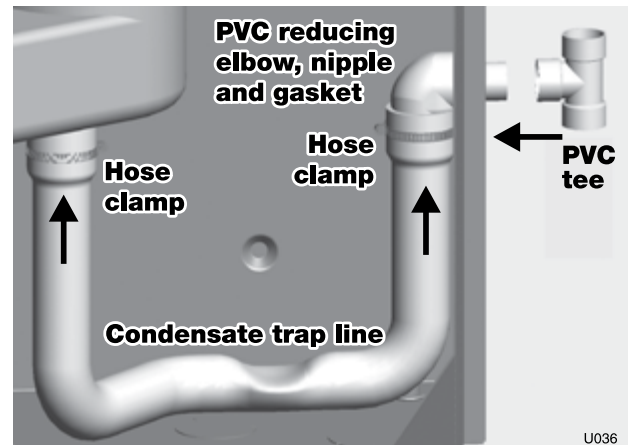

Figure 31 Condensate drain — Ultra-299 & -399

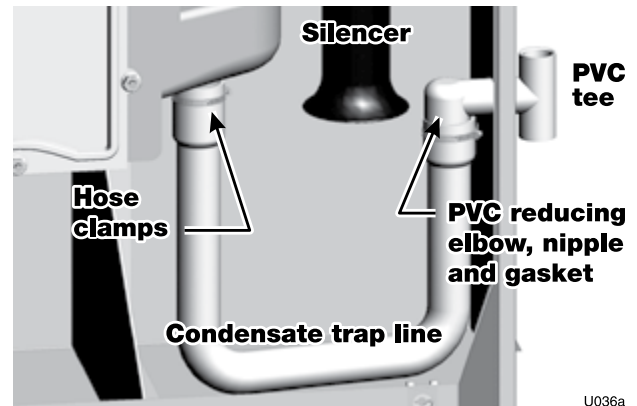
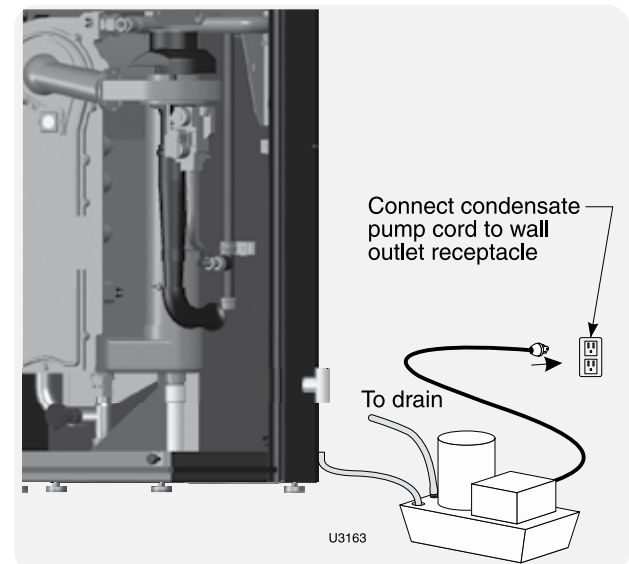

Figure 32 Condensate pump (by others), typical



Gas piping

Connecting gas supply piping

- Remove jacket front panel and refer to Figure 33 to pipe gas to boiler.
 - Install ground joint union for servicing, when required.
 - Install manual shutoff valve in gas supply piping outside boiler jacket when required by local codes or utility requirements.
 - In Canada — When using manual main shutoff valve, it must be identified by the installer.
- Wall-mounted boilers
 - Refer to separate Ultra Boiler Wall-mounting instructions.
 - Gas connection may enter from the bottom of boiler as explained in the Wall-mounting instructions.
- Support piping with hangers, not by boiler or its accessories.
- Purge all air from gas supply piping.
- Before placing boiler in operation, check boiler and its gas connection for leaks.
 - Close manual main shutoff valve during any pressure testing at less than 13" w.c.
 - Disconnect boiler and gas valve from gas supply piping during any pressure testing greater than 13" w.c.

▲WARNING Do not check for gas leaks with an open flame — use bubble test. Failure to use bubble test or check for gas leaks can cause severe personal injury, death or substantial property damage.

- Use pipe dope compatible with propane gases. Apply sparingly only to male threads of pipe joints so that pipe dope does not block gas flow.

▲WARNING Failure to apply pipe dope as detailed above can result in severe personal injury, death or substantial property damage.

▲WARNING DO NOT adjust or attempt to measure gas valve outlet pressure. The gas valve is factory-set for the correct outlet pressure. This setting is suitable for natural gas and propane, requiring no field adjustment. Attempting to alter or measure the gas valve outlet pressure could result in damage to the valve, causing potential severe personal injury, death or substantial property damage.

▲WARNING Ultra boilers are shipped ready to fire natural gas ONLY. (Exception: Ultra-80LP is propane-ready.) You must install the propane orifice if the boiler will be connected to propane. See page 48. Failure to comply could result in severe personal injury, death or substantial property damage.

Gas pipe sizing

- See page 93 for gas line sizing information.

Check gas pressure at inlet to boiler

- See Figure 39, page 40, Figure 40, page 40, or Figure 41, page 41 for location of the gas inlet pressure test port.

▲WARNING

Use two wrenches when tightening gas piping at boiler, using one wrench to prevent the boiler gas line connection from turning. Failure to support the boiler gas connection pipe to prevent it from turning could damage gas line components.

Figure 33 Connect gas supply piping

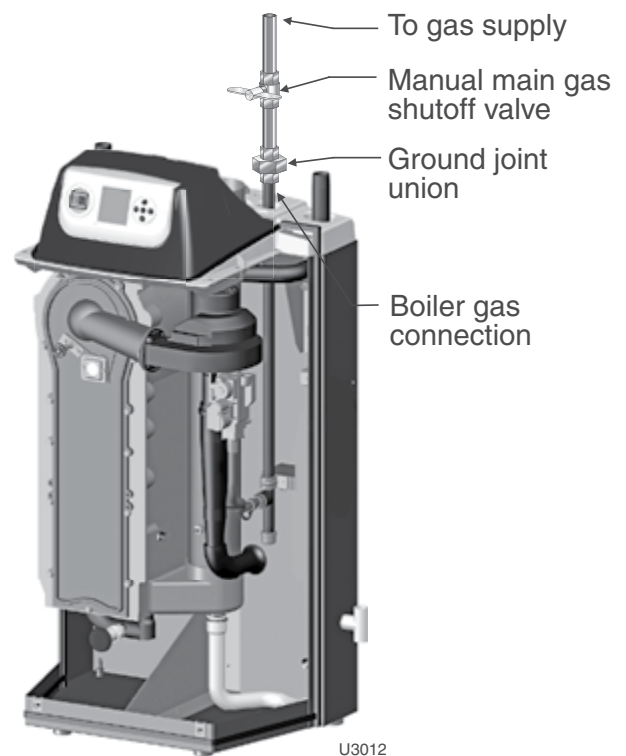

Natural gas supply pressure

- Pressure required at gas valve inlet pressure port:
 - Maximum: 13" w.c. with no flow (lockup) or with boiler on
 - Minimum: 4" w.c. (for all except 5" for -299) with gas flowing (verify during boiler startup, while boiler is at high fire)
- Install 100% lockup gas pressure regulator in supply line if inlet pressure can exceed 13" w.c. at any time. Adjust lockup regulator for 13" w.c. maximum.

Propane supply pressure

- Adjust propane supply regulator provided by gas supplier for 13" w.c. maximum pressure.
- Pressure required at gas valve inlet pressure port:
 - Maximum: 13" w.c. with no flow (lockup) or with boiler on
 - Minimum: 4" w.c. with gas flowing (verify during boiler startup, while boiler is at high fire).



Field wiring — basic system

⚠ WARNING **ELECTRICAL SHOCK HAZARD** — For your safety, turn off electrical power supply at service entrance panel before making any electrical connections to avoid possible electric shock hazard. Failure to do so can cause severe personal injury or death.

NOTICE The installation must comply with: National Electrical Code and any other national, state, provincial or local codes or regulations. In Canada, CSA C22.1 Canadian Electrical Code Part 1, and any local codes.

NOTICE Wiring must be N.E.C. Class 1. If original wiring as supplied with boiler must be replaced, use only type 105 °C wire or equivalent. Boiler must be electrically grounded as required by National Electrical Code ANSI/NFPA 70 – latest edition, and/or the Canadian Electrical Code Part I, CSA C22.1, Electrical Code.

NOTICE The boiler when installed, must be electrically bonded to ground in accordance with the requirements of the authority having jurisdiction or, in the absence of such requirements, with the National Electrical Code, ANSI/NFPA 70 – latest edition, and/or the Canadian Electrical Code Part I, CSA C22.1, Electrical Code.

Wiring — general

1. The U-Control provides plug-in, color-coded, non-interchangeable terminal strips for all field wiring. See the schematic diagram (Figure 111, page 96) & ladder diagram (Figure 112, page 97).
2. The U-Control provides programmable flexibility in system operation, allowing control of heat supply for up to three different heating systems. Read this manual thoroughly before connecting the wiring to ensure trouble-free start-up and operation.

Wiring — overview

See this and following pages for wiring information. Also see the Advanced section of this manual for additional wiring connections and options.

Make the following connections, some of which depend on your system and how the U-Control will be programmed.

- Connect 120VAC power (minimum 15-amp source)**
- Connect wiring for up to three circulators**
- Connect thermostats and/or heat demand contacts**
 - The U-Control can regulate the boiler for up to three different heating systems.
- Install system & outdoor sensors, when used**
 - The boiler is shipped with an outdoor sensor, a system supply sensor and a system return sensor. The system supply sensor will be required for most space heating applications. The system return sensor must also be installed when using the system supply sensor. Use of the outdoor sensor is optional.
 - Locate the sensors on the system piping as shown in Figure 4, page 11 and other piping drawings throughout this manual.

Line voltage power input

1. Provide and install a fused disconnect or service switch (15-ampere rated recommended) as required by applicable codes.
2. Connect minimum 15-ampere, 120 VAC power wiring to Ultra boiler line voltage terminal strip as shown in Figure 34, page 31, and Figure 111, page 96.

Wiring circulators

1. The U-Control provides for connection of up to three circulators, one of which must be the boiler circulator. In addition, you can connect a system circulator and a DHW circulator, for examples.

⚠ WARNING **The maximum allowable current for each circulator is 2.2 amps at 120 VAC.** For circulators with higher amp ratings, you must install a circulator relay or starter to provide line voltage to the circulator. For circulators rated over 2.2 amps, connect only the circulator relay or starter coil to the Ultra circulator terminals.

See page 94 (Advanced section) for other wiring options

Field wiring — basic system *(continued)*

Figure 34 Simplified wiring — basic system with DHW and space heating (see ADVANCED section for more information)

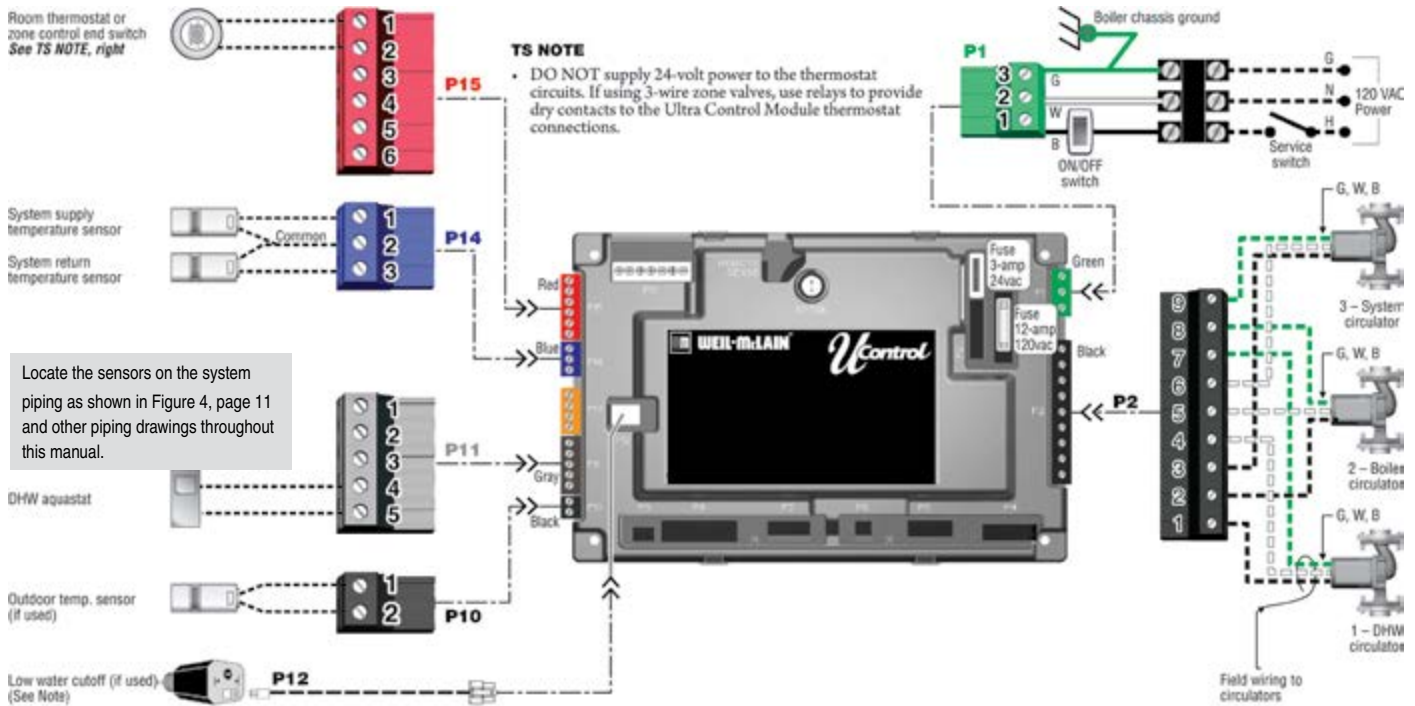

Wire the DHW tank aquastat to the U-Control “heat demand 1” input, terminals P11 #4 and #5.

Wire the space heating thermostat (or zone controller or zone valve end switches) across the U-Control “heat demand 2” input, terminals P15 #1 and #2.

Attach a sensor (supplied with boiler) to the system supply pipe and wire to terminals P14 #1 and #2.
 [Locate sensor in the position shown in piping diagrams on page 11 through page 15.]

Attach a sensor (supplied with boiler) to the system return pipe and wire to terminals P14 #2 and #3.
 [Locate sensor in the position shown in piping diagrams on page 11 through page 15.]

Install the outdoor temperature sensor (supplied with boiler) and wire to terminals P10 #1 and #2.

The outdoor sensor must be installed unless specifically exempted in the Energy Act statement on page 137.

Wire the DHW circulator (supplied by installer) as circulator 1, following instructions on Connect the boiler circulator (supplied with boiler) as circulator 2, following instructions on page 30.

Wire the boiler circulator (supplied with boiler) as circulator 2, following instructions on page 30.

Wire the system circulator (supplied by installer) as circulator 3, following the instructions on page 30.

NOTICE

Detailed control information and additional wiring — see the ADVANCED INSTALLATION section of this manual.



U-Control operation and setup

⚠️ WARNING **Temperature settings** — You must ensure that the U-Control is set for the proper water temperatures for the system. Excessive water temperature can cause significant property damage in some applications.

Multi-temperature systems — If the heating system includes circuits that require lower temperature water (radiant slab circuits, for example) as well as higher temperature circuits (DHW, finned tube baseboard, etc.), it is recommended to protect low-temperature circuits with limit controls that are wired to a U-Control external limit circuit. Failure to provide regulation can result in substantial property damage.

U-Control overview

The U-Control is fully programmable to meet system requirements, allowing supply water regulation for up to three different systems.

U-Control features include:

- Blower speed modulation to control the Ultra boiler’s firing rate.
- Advanced PID response to anticipate system needs based on response to heat input.
- Graphic and robust text display for ease of operation monitoring and troubleshooting.
- Preset operating parameters for typical heating systems (finned tube baseboard, radiant floor, DHW, and others), including target temperatures, reset curves and circulator assignments.
- Control of up to three circulators (boiler circulator plus two others), assignable for each of the three possible inputs.
- Programmable priority assignments for the heat inputs.
- Integral outdoor reset option, with reset curves matched to the system type selected.
- Multiple boiler/heat source sequencing or modulation.
- Built-in 0–10 VDC signal generator to allow parallel modulation of multiple boilers; also capable of accepting 0–10 VDC input.
- Dual sensors for boiler outlet temperature and flue temperature, providing redundant protection.
- Integral low water protection (by monitoring boiler heat exchanger temperature).
- Boiler is shipped with an outdoor sensor and strap-on system supply and return sensors.

Sequence of operation

1. Figure 35 is a summary of the operating sequence for the U-Control.
2. The symbols shown appear in the display as the U-Control cycles the boiler.
3. The wrench symbol appears when a scheduled maintenance date arrives. This informs the homeowner to call the contractor for service.
4. The exclamation mark symbol appears when a problem has been detected.

Figure 35 U-Control sequence of operation

Display	Control action <i>(also see Figure 36, page 33)</i>
POWER UP	<ul style="list-style-type: none"> • Check the boiler model listed on the power-up screen. If it is not correct, turn off the boiler. See Figure 115, page 102 to change setting. • When power is turned on, the screen lists sensors that are detected. If any sensor is not listed, make sure it is connected correctly. Turn off power and restart.
Standby	<ul style="list-style-type: none"> • Standby — no calls for heat • Toggles through no dots, 1 dot, 2 dots, then 3 dots while in standby (wrench symbol will show instead if maintenance is needed)
Blower on	<ul style="list-style-type: none"> • Call for heat detected • Display on with BLUE light (space heating) or PURPLE light (DHW) • Start min/max on timers if more than one system is calling — highest priority starts first • Start circulators for this priority setup • Calculate target temp — If sensor temp is below target temp, begin firing sequence • Blower to ignition speed for prepurge • Multiple boilers/heat sources only — Start additional-heat timer — type 1 boiler starts immediately; type 2 activates other heat source immediately, but doesn’t start unless the timer times out; type 3 (LEAD boiler) starts immediately and sends 0–10 VDC signal to others after timer times out; type 4 receives signal from LEAD boiler and starts immediately (and starts timer for the next boiler, if programmed)
Ignition on	<ul style="list-style-type: none"> • After prepurge times out, begin ignition cycle • Activate gas valve and ignition spark • Continue ignition spark for ignition period • Turn off spark and use electrode to check for flame signal
Space heating	<ul style="list-style-type: none"> • Flame detected • Hold boiler at low fire for 1 minute • Release boiler to modulation • NOTE: If flame is not detected, the gas valve is turned off, blower turns on (postpurge), and control starts cycle again. After 5 failures, the control waits 60 minutes, then tries again. • If priority timer times out, switch to next priority and start priority timer • If demand satisfied, go to postpurge
DHW heating	<ul style="list-style-type: none"> • Flame detected • Release boiler to modulation immediately • NOTE: If flame is not detected, the gas valve is turned off, blower turns on (postpurge), and control starts cycle again. After 5 failures, the control waits 60 minutes, then tries again. • If priority timer times out, switch to next priority and start priority timer • If demand satisfied, go to postpurge
Blower on	<ul style="list-style-type: none"> • Demand satisfied (temperature reaches target temperature or limit setting) • Gas valve off • Blower to ignition speed for postpurge • Return to standby after purge
Maintenance	<ul style="list-style-type: none"> • Display turns RED, toggling between graphic screen and maintenance screen (occurs when maintenance schedule timer times out) • Will show during standby only • Boiler operates as normal
Error/fault	<ul style="list-style-type: none"> • Display turns RED due to error or limit event • Flashing display means lockout condition — display toggles between three screens as in Figure 124, page 117.
WWSD	<ul style="list-style-type: none"> • Warm weather shutdown — the boiler will not be allowed to fire if the outside temperature is greater than the WWSD setting.



U-Control operation and setup *(continued)*

Figure 36 U-Control display and navigation

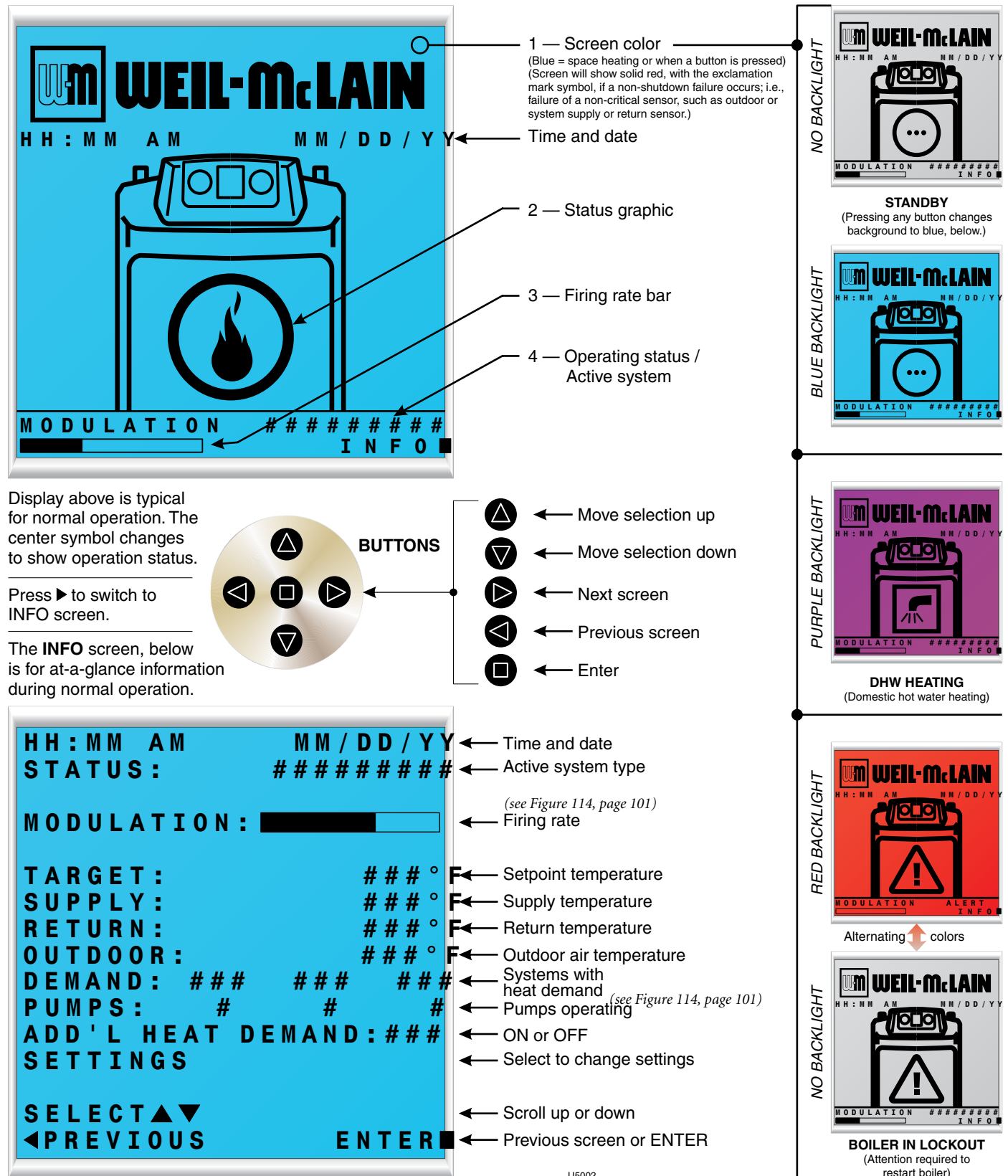

BASIC INSTALLATION



U-Control operation and setup *(continued)*

NOTICE For detailed control information and additional wiring, see the ADVANCED INSTALLATION section of this manual.

WARNING Low-temperature systems (radiant slab, etc.) — **DO NOT** use the Ultra boiler control as the only means of water temperature regulation for low-temperature systems if higher-temperature systems are also supplied.

EXPRESS SETUP — using default settings

1. The U-Control is factory programmed to supply a DHW circuit (control priority 1) and finned tube baseboard space heating (control priority 2).
2. Control priority 3 is also available, and preset to run all three circulators if desired, but requires settings to be configured.

Figure 37 Factory default settings

Priority	Type	Target temperature	Circulators enabled
1	DHW Direct	190°F	#1 Only
2	Finned tube BB	180°F fixed (if no outdoor sensor) or 180°F at 0°F outside / 130°F at 70°F outside	#2 and #3
3	Custom	180°F fixed (if no outdoor sensor) or 180°F at 0°F outside / 130°F at 70°F outside	None

3. You can use the factory default settings for most systems supplying space heating with finned-tube baseboard with or without a DHW tank, provided:
 - a. A DHW tank, if used, must be piped directly to the boiler, as in the piping shown in Figure 5, page 12 or Figure 6, page 13.
 - b. If the DHW tank is a separate zone off of the system main, or if it is piped as in Figure 48, page 52, you will need to enable additional circulators for DHW operation. The U-Control is factory programmed to operate only the DHW circulator during DHW heating.
 - c. The heat emitters in the system must be finned tube baseboard only. Other heat emitters require changes in the U-Control setup. See ADVANCED INSTALLATION section for information.
4. Wiring to use the factory default settings — see information in Figure 34, page 31 for wiring instructions.

Startup — fill the system

Clean system to remove sediment

1. You must thoroughly flush the system (without boiler connected) to remove sediment. The high-efficiency heat exchanger can be damaged by buildup or corrosion due to sediment.
2. For zoned systems, flush each zone separately through a purge valve. (If purge valves and isolation valves are not already installed, install them to properly clean the system.)
3. Flush system until water runs clean and you are sure piping is free of sediment.

⚠ WARNING

Do not use petroleum-based cleaning or sealing compounds in boiler system. Damage to elastomer seals and gaskets in system could occur, resulting in substantial property damage.

Before filling the boiler and system with water, verify the following. **DO NOT fill with softened water.** Boiler corrosion can occur.

Failure to comply could result in boiler failure or unreliable operation.

Water chemistry

Water pH between 7.0 and 8.5

1. Maintain boiler water pH between 7.0 and 8.5. Check with litmus paper or have chemically analyzed by water treatment company.
2. If pH differs from above, consult local water treatment company for treatment needed.
3. DO NOT use softened water. Softened water can cause corrosion.

Hardness less than 7 grains

1. Consult local water treatment companies for unusually hard water areas (above 7 grains hardness).

Chlorine concentration must be LESS THAN 200 ppm

1. Filling with chlorinated fresh water should be acceptable since drinking water chlorine levels are typically less than 5 ppm.
2. Do not use the boiler to directly heat swimming pool or spa water.
3. Do not fill boiler or operate with water containing chlorine in excess of 200 ppm.

Antifreeze

1. Use only antifreeze listed by Weil-McLain as suitable for use with Ultra Gas Boilers. A list of approved antifreeze products is available at www.Weil-McLain.com.
2. See Replacement parts at the end of this manual for Weil-McLain part numbers to obtain antifreeze through a Weil-McLain distributor.

Use the correct amount of antifreeze

1. Determine the freezing temperature needed (to protect against lowest likely temperature the system water will encounter).
2. Find the antifreeze concentration by volume needed for this temperature from the antifreeze manufacturer's data on the antifreeze container.
3. Add up the volume (gallons) of all system piping and components, including the expansion tank and boiler.
 - a. Boiler water content is listed on page 137.
 - b. Remember to include expansion tank water content.
4. Multiply this volume by the (percent) antifreeze needed to find the number of gallons of antifreeze to add.

Fill and test water system

1. Fill system only after ensuring the water meets the requirements of this manual.
2. Close manual and automatic air vents and boiler drain valve.
3. Fill to correct system pressure. Correct pressure will vary with each application.
 - a. Typical cold water fill pressure for a residential system is 12 psi.
 - b. Pressure will rise when boiler is turned on and system water temperature increases. Operating pressure must never exceed 25 psig.
4. At initial fill and during boiler startup and testing, check system thoroughly for any leaks. Repair all leaks before proceeding further.

⚠ WARNING

Eliminate all system leaks. Continual fresh make-up water will reduce boiler life. Minerals can build up in sections, reducing heat transfer, overheating heat exchanger, and causing heat exchanger failure.

⚠ WARNING

X100 inhibitor is required

1. It is required that the Ultra boiler have Sentinel X100 added to the system to prevent damage to the boilers' heat exchanger. Replacement Parts section at the end of this manual for re-ordering information.
2. After filling the system as directed in these instructions, use a caulking gun to inject the X100 inhibitor concentrate into the system, or fill with the X100 in its liquid form, following the instructions on the tube or container.
3. After adding the inhibitor to the system, allow time for the water to circulate and mix. Then check the inhibitor level. Add additional inhibitor if necessary.
4. See separate instructions or Weil-McLain website for suggested guidelines to determine how much inhibitor to use.

Startup — fill the system *(continued)*

Freeze protection (when used)

⚠ WARNING Follow these guidelines to prevent possibility of severe personal injury, death or substantial property damage:

NEVER use automotive or standard glycol antifreeze, even glycol made for hydronic systems. Use only freeze-prevention fluids recommended by Weil-McLain for application in Ultra Boiler systems.

Thoroughly flush any system that has used glycol before installing the new Ultra boiler.

Review the material safety data sheet (MSDS) for the fluid used with the boiler owner and leave a copy for reference. The MSDS contains information on potential hazards and first aid procedures for exposure or ingestion.

Check antifreeze inhibitor level at least annually. Glycol concentration and inhibitor levels may change over time. Add antifreeze to increase concentration if necessary. Add inhibitor as needed to bring to acceptable level, using inhibitor test kit to verify.

When using freeze protection fluid with automatic fill, **install a water meter to monitor water make-up.** Freeze protection fluid may leak before the water begins to leak, causing concentration to drop, reducing the freeze protection level.

DO NOT exceed 50% antifreeze by volume. Antifreeze moves more sluggishly than water and can interfere with heat transfer. At antifreeze concentrations higher than 50%, sludge can develop in the boiler, potentially causing damage to the heat exchanger.

Clean the system before filling. Always drain and flush the system thoroughly before filling with antifreeze. Sludge, iron oxide deposits and other sediment in the system inhibit flow and can cause rapid breakdown of inhibitors.

Use only antifreeze recommended by Weil-McLain.

NOTICE Weil-McLain provides information for application of the antifreeze products listed in this document only for use in Weil-McLain Ultra boilers. Do not apply these products or instructions for other applications. Local codes may require a backflow preventer or actual disconnection from city water supply.

Check/verify water chemistry

1. The system may have residual substances that could affect water chemistry.
2. After the system has been filled and leak tested, verify water pH and chlorine concentrations are acceptable.
3. Verify antifreeze concentration, when used.
4. Follow the instructions on the Sentinel test kit to sample the system water and verify inhibitor concentration.

Check inhibitor concentration annually

1. Test the pH of a sample of system water at least annually. The pH of the water mixture must be between 7.0 and 8.5. (Or use the Sentinel inhibitor test kit to check concentration.)
2. If pH is outside this range (or inhibitor test kit indicates low level), the inhibitor level may not be sufficient to prevent corrosion.
3. Test antifreeze concentration.

⚠ WARNING Test antifreeze concentration at least annually. If concentration is low, add antifreeze or drain system and refill with correct mixture.

4. Follow instructions on antifreeze container to determine the amount of antifreeze needed. **DO NOT** exceed 50% by volume concentration of antifreeze.
5. Check inhibitor level after adjustments are made.

Purge air from water system

1. Connect a hose to the purge valve (see purge/drain valves, item 11, in piping diagrams beginning on page 12 and page 52. Route hose to an area where water can drain and be seen.
2. Close the boiler or system isolation valve between the purge valve and fill connection to the system.
3. Close zone isolation valves.
4. Open quick-fill valve on cold water make-up line.
5. Open purge valve.
6. One zone at a time, open the isolation valves. Allow water to run through the zone, pushing out the air. Run until no noticeable air flow is present. Close the zone isolation valves and proceed with the next zone. Follow this procedure until all zones are purged.
7. Close the quick-fill water valve and purge valve and remove the hose. Open all isolation valves. Watch that system pressure rises to correct cold-fill pressure.
8. After the system has operated for a while, eliminate any residual air by using the manual air vents located throughout the system.
9. If purge valves are not installed in system, open manual air vents in system one at a time, beginning with lowest floor. Close vent when water squirts out. Repeat with remaining vents.
10. Open automatic air vent (diaphragm-type or bladder-type expansion tank systems only) one turn.
11. Starting on the lowest floor, open air vents one at a time until water squirts out.
12. Repeat with remaining vents.
13. Refill to correct pressure.

Startup — final checks

Check for gas leaks

▲WARNING

Before starting the boiler, and during initial operation, use a leak detector or smell near the floor and around the boiler for gas odorant or any unusual odor. Remove boiler front door and smell interior of boiler enclosure. Do not proceed with startup if there is any indication of a gas leak. Repair any leak at once.

DO NOT adjust or attempt to measure gas valve outlet pressure. The gas valve is factory-set for the correct outlet pressure. This setting is suitable for natural gas and propane, requiring no field adjustment. Attempting to alter or measure the gas valve outlet pressure could result in damage to the valve, causing potential severe personal injury, death or substantial property damage.

Propane boilers only — Your propane supplier mixes an odorant with the propane to make its presence detectable. In some instances, the odorant can fade, and the gas may no longer have an odor. Before startup (and periodically thereafter), have the propane supplier verify the correct odorant level in the gas.

Check thermostat circuit(s)

1. Disconnect the two external wires connected to the boiler thermostat terminals (see Field wiring, beginning on page 30 for terminal locations).
2. Connect a voltmeter across these two incoming wires. Close each thermostat, zone valve and relay in the external circuit one at a time and check the voltmeter reading across the incoming wires.
3. There should NEVER be a voltage reading.
4. If a voltage does occur under any condition, check and correct the external wiring. (This is a common problem when using 3-wire zone valves.)
5. Once the external thermostat circuit wiring is checked and corrected if necessary, reconnect the external thermostat circuit wires. Allow the boiler to cycle.

Inspect/fill condensate system

Inspect/check condensate lines and fittings

1. Inspect the condensate drain line, condensate PVC fittings and condensate trap. (See page 27 for component locations.)
2. Pour water into the top of the boiler's ½" PVC condensate tee and check for any leaks in the condensate drain line or fittings. Repair any leaks.

Fill condensate trap with water

1. Loosen the hose clamp securing the right end of the condensate trap to the PVC reducing elbow (see page 27 for details).
2. Slide the trap hose end off of the elbow.
3. Fill the trap with fresh water to within an inch of the end of the hose.
4. Replace trap hose on PVC reducing elbow and tighten the hose clamp.

▲WARNING

The condensate trap must be filled with water during all times of boiler operation to avoid flue gas emission from the condensate drain line. [Prime the condensate trap (by pouring water into the outlet tee while restricting flow in drain tube) if boiler has been out of service for an extended period.] Failure to fill the trap could result in severe personal injury or death.

Final checks before starting boiler

- Read the instructions to adjust and set up the U-Control module.
- Verify that the boiler model is set correctly in the U-Control, and that it displays correctly.
- Verify that the boiler and system are full of water and all system components are correctly set for operation.
- Fill vent condensate trap with water (by removing hose clamp and hose at PVC reducing elbow). Replace hose on PVC reducing elbow and tighten clamp.
- Verify electrical connections are correct and securely attached.
- Inspect vent piping and air piping for signs of deterioration from corrosion, physical damage or sagging. Verify air piping and vent piping are intact and correctly installed per this manual.



Startup — final checks *(continued)*

To start the boiler

1. Turn OFF the boiler ON/OFF switch.
2. Read and follow the Operating Instructions, Figure 38, page 39.
3. The U-Control display will show installed sensors when first powered. Make sure the right sensors are detected. If not, determine the cause and correct before proceeding.

If boiler does not start correctly

1. Check for loose connections, blown fuse or service switch off?
2. Is external limit control (if used) open? Is boiler water temperature above 200 °F?
3. Is thermostat set below room temperature?
4. Is gas turned on at meter or boiler?
5. Is incoming gas pressure less than 5" w.c. for natural gas or 4" w.c. for propane?
6. Are parameters set correctly in this manual?
7. Is the warm weather shutdown activated?
8. If none of the above corrects the problem, refer to Troubleshooting, beginning on page 115.

☐ Check system and boiler

☐ Check water piping

9. Check system piping for leaks. If found, shut down boiler and repair immediately. (See WARNING on page 35 regarding failure to repair leaks.)
10. Vent any remaining air from system using manual vents. Air in the system will interfere with circulation and cause heat distribution problems and noise.

☐ Check vent piping and air piping

1. Check for gas-tight seal at every connection and seam of air piping and vent piping.

▲WARNING Venting system must be sealed gas-tight to prevent flue gas spillage and carbon monoxide emissions which will result in severe personal injury or death.

☐ Check gas piping

1. Check around the boiler for gas odor following the procedure of page 29 of this manual.

▲WARNING If you discover evidence of any gas leak, shut down the boiler at once. Find the leak source with bubble test and repair immediately. Do not start boiler again until corrected. Failure to comply could result in severe personal injury, death or substantial property damage.

☐ Propane boilers — verify conversion

1. Verify propane orifice has been installed per Propane Conversion instructions.

▲WARNING DO NOT adjust or attempt to measure gas valve outlet pressure. The gas valve is factory-set for the correct outlet pressure. This setting is suitable for natural gas and propane, requiring no field adjustment.

Attempting to alter or measure the gas valve outlet pressure could result in damage to the valve, causing potential severe personal injury, death or substantial property damage.

Ultra boilers are shipped ready to fire natural gas ONLY. Exception: The Ultra-80LP is factory-equipped to fire propane. You must install the propane orifice if the boiler will be connected to propane. See page 48.

Failure to comply could result in severe personal injury, death or substantial property damage.

Startup — final checks *(continued)*

Figure 38 Operating instructions (WARNING — Verify that the U-Control is set for the correct boiler model before proceeding.)

**FOR YOUR SAFETY
READ BEFORE OPERATING**

WARNING

If you do not follow these instructions exactly, a fire or explosion may result causing property damage, personal injury or loss of life.

A. This appliance does not have a pilot. It is equipped with an ignition device which automatically lights the burner. Do not try to light the burner by hand.

B. Before OPERATING, smell all around the appliance area for gas. Be sure to smell next to the floor because some gas is heavier than air and will settle on the floor. See below.

C. Use only your hand to toggle the power switch and/or turn the manual gas valve. If the switch or valve will not turn by hand, don't try to repair it, call a qualified service technician. Force or attempted repair may result in a fire or explosion.

D. Do not use this appliance if any part has been under water. Immediately call a qualified service technician to inspect the appliance and to replace any part of the control system and any gas control, which has been under water.

WHAT TO DO IF YOU SMELL GAS

- Do not try to light any appliance.
- Do not touch any electric switch; do not use any phone in your building.

- Immediately call your gas supplier from a neighbor's phone. Follow the gas supplier's instructions.
- If you cannot reach your gas supplier, call the fire department.

OPERATING INSTRUCTIONS

1. **STOP!** Read the safety information at left on this label. This appliance is equipped with an ignition device which automatically lights the burner. Do not try to light the burner by hand.
2. Set room thermostat(s) to lowest setting.
3. Turn OFF all electrical power to the appliance.
4. Toggle the power switch located on Boiler to "off" position.
5. Locate boiler manual gas valve (in the gas piping connected to the boiler).
6. Turn boiler manual gas valve knob counterclockwise ↺ to open gas supply.
7. Wait five (5) minutes to clear out any gas. Then smell for gas, including near the floor.
8. If you smell gas, **STOP!** Turn the boiler manual gas valve to OFF. Then follow **WHAT TO DO IF YOU SMELL GAS**. If you don't smell gas, go to step 9, below.
9. Turn ON all electrical power to the appliance including the power switch located on Boiler.
10. Set thermostat(s) to desired setting.
11. The boiler display will show symbols and/or text describing the status of the boiler as it proceeds through its operating sequence. "Standby" status means the burner is off.
12. If the appliance will not operate when there is a call for heat and piping is not hot, follow the instructions "To Turn Off Gas To Appliance" below and call your service technician or gas supplier.



(ON Position Shown)

Gas valve CLOSED



to OPEN

Gas valve OPEN

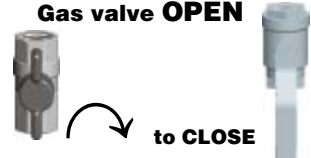

to CLOSE
(Typical gas valve shown; Actual valve may vary)

TO TURN OFF GAS TO THE APPLIANCE

1. Set room thermostats to lowest setting.
2. Turn OFF all electrical power to the appliance including the power switch located on Boiler.

3. Close external manual gas cock (valve handle perpendicular to gas piping). Turn gas valve knob clockwise ↻ to close gas supply.
4. Replace boiler access door.



550-101-272 (0617)



Startup — final checks *(continued)*

☐ Check flame & combustion with instruments

▲WARNING For Ultra-399 propane boilers, special start-up is required. See page 41 for procedure. See DANGER on page 49 before proceeding.

1. Initiate a call for heat on one of the heat demand inputs.
2. Access the U-Control installer menus by pressing and holding the UP and DOWN arrow keys for five seconds.
3. Use the U-Control display to navigate to Manual test mode (see Figure 115, page 102) and force the firing rate to MAX (high fire).
4. Look at the flame through the flame inspection window. The high fire flame should be blue and should be stable. The burner surface should be covered with orange dots.
5. Remove the flue temperature sensor from the flue pipe and insert a combustion test probe., using a calibrated combustion test instrument.
6. Test for CO₂ (or O₂) and for CO. The CO₂ values must be within 1.0% of the values listed in Figure 42, page 41. If results are acceptable, proceed to step 7. IF NOT, follow the instructions under “Throttle screw adjustment procedure” to set the throttle screw position. See WARNING below.

▲WARNING If combustion at either high or low fire is outside the range given in Figure 42, follow the procedure given on page 41 for adjusting the throttle screw on the venturi. If throttle screw adjustment does not correct the problem, then shut down the boiler and contact your local Weil-McLain representative. Throttle screw adjustment must be done only by a qualified technician, using calibrated test instruments. Failure to comply could result in severe personal injury, death or substantial property damage.

7. Measure natural gas input:
 - a. Operate boiler 10 minutes.
 - b. Turn off other appliances.
 - c. At natural gas meter, measure time (in seconds) required to use one cubic foot of gas.
 - d. Calculate gas input:

$$\frac{3600 \times 1000}{\text{number of seconds from step c}} = \text{Btuh}$$
 - e. Btuh calculated should approximate input rating on boiler rating label.
8. Use the U-Control display to navigate to Manual test mode (see Figure 115, page 102) and force the firing rate to MIN (low fire).
9. Look at the flame through the flame inspection window. The low fire flame should be stable and evenly distributed over burner surface with a uniform orange color.
10. Repeat the combustion test of steps 4 and 5 above.
11. Use the U-Control display to navigate to Manual test mode (see Figure 115, page 102) and force the firing rate to AUTO (normal operation).
12. Replace the flue gas temperature sensor. When replacing the sensor, remove the rubber grommet from the probe. Insert the rubber grommet into the flue pipe, then insert the probe into the rubber grommet.

Figure 39 Models 80 & 105 — Throttle screw location (ONLY for use by a qualified technician, using calibrated combustion test instruments)

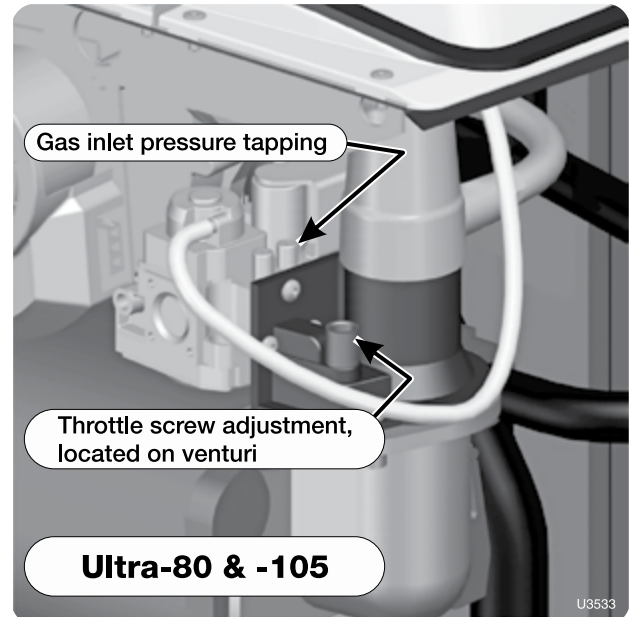
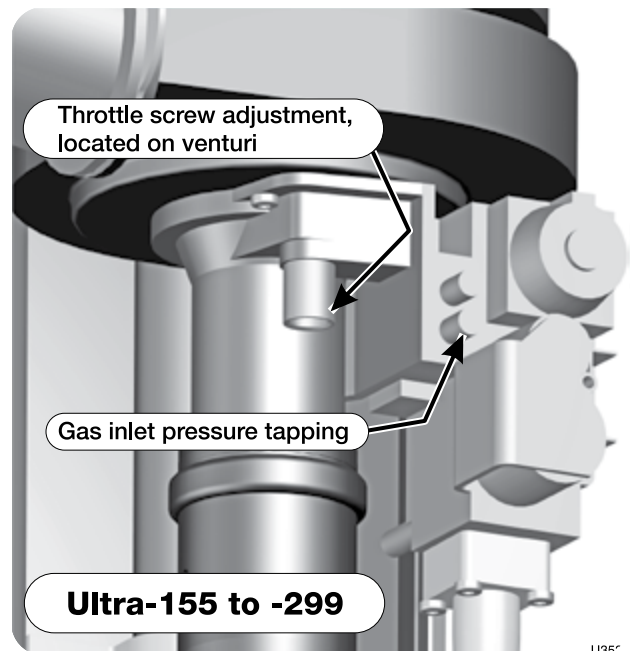

Figure 40 Models 155, 230 & 299 — Throttle screw location (ONLY for use by a qualified technician, using calibrated combustion test instruments)





Startup — final checks *(continued)*

⚠WARNING You must replace the flue gas temperature sensor to prevent flue gas spillage into the boiler enclosure. Failure to comply could result in severe personal injury, death or substantial property damage.

Ultra-399 propane conversion & start-up

Ultra-399 boilers are converted for propane by adjustment of the gas valve throttle screw (no orifice change) — Figure 41. This must only be done while using a combustion analyzer.

1. Turn the gas valve throttle screw clockwise 5 turns before starting the boiler. Then follow the start-up procedure on page 40.
2. Once the boiler is started, make slight adjustments to the throttle screw to obtain a CO₂ of 10.2% with CO less than 100 ppm air free. (Allow the combustion analyzer's reading to stabilize before making adjustments.)
3. After the boiler has been set up correctly, the conversion is complete. Fill in the information on the propane conversion label and attach the label to the boiler rating plate.

Throttle screw adjustment procedure

See Figure 39, page 40, Figure 40, page 40, or Figure 41 for location of the throttle screw.

⚠WARNING DO NOT attempt to adjust the throttle screw unless by a qualified technician, and with the use of calibrated combustion test instruments. Adjust the throttle screw only as needed to meet the combustion values given in Figure 42.

1. This procedure is only necessary when specified elsewhere in this manual or when combustion tests indicate the need, as explained under "☐ **Check flame & combustion with instruments**, page 40."
2. Boiler behavior that might indicate a need to check combustion values at high fire (as per page 40) to verify boiler is in adjustment include: difficulty igniting, poor flame stability at low fire, combustion noise or high carbon monoxide values.
3. Combustion readings must be taken at both high fire and low fire. DO NOT attempt an adjustment of the throttle screw at low fire. Just check the combustion values.
4. Use the U-Control display to navigate to Manual test mode (see Figure 115, page I02) and force the firing rate to MAX (high fire). After the boiler has had time to stabilize, take a CO₂ reading.
 - a. If the CO₂ is HIGH, turn the throttle screw CLOCKWISE to lower the input. Allow the boiler to stabilize and take another reading. Continue until the desired CO₂ value is achieved.
 - b. If the CO₂ is LOW, turn the throttle screw COUNTER-CLOCKWISE to increase the input. Allow the boiler to stabilize and take another reading. Continue until the desired CO₂ value is achieved.
5. Lock the boiler into low fire. Check the combustion readings. If results are acceptable at low fire, verify high fire readings again. Restore firing rate to AUTO.
6. Consult your local Weil-McLain representative if acceptable results cannot be obtained for both high and low fire.

Figure 41 Model 399 — Throttle screw location (ONLY for use by a qualified technician, using calibrated combustion test instruments)

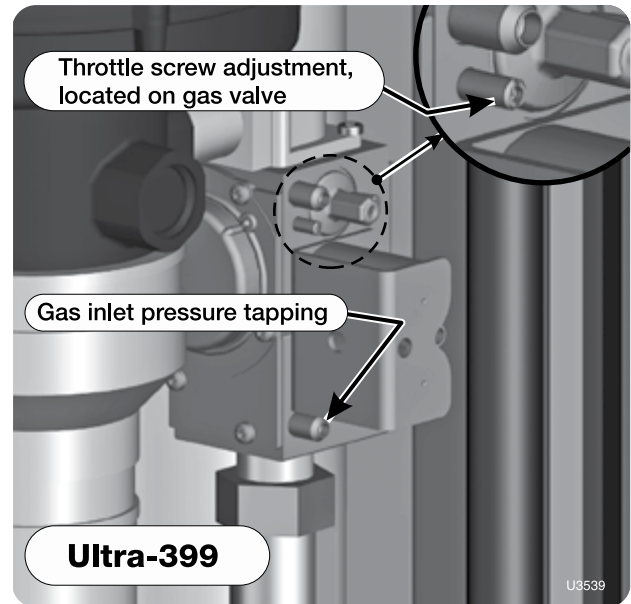

☐ Adjust and test boiler controls

1. Follow instructions in this manual to set and verify operation of the boiler controls.

Figure 42 Acceptable CO₂ and CO values (CO₂ values must be within 1.0% of the values listed)

Boiler Ultra	Fuel	High fire		Low fire	
		%CO ₂	CO ppm	%CO ₂	CO ppm
-80	NG	8.6	< 60	7.8	< 60
	LP	9.6	< 60	8.6	< 60
-105	NG	9.0	< 60	8.4	< 60
	LP	10.1	< 60	9.2	< 60
-155	NG	9.0	< 60	8.0	< 60
	LP	10.0	< 60	8.5	< 60
-230	NG	9.0	< 60	8.0	< 60
	LP	10.0	< 60	9.0	< 60
-299	NG	9.0	< 60	8.0	< 60
	LP	10.0	< 60	9.0	< 60
-399	NG	9.2	< 100	8.4	< 60
	LP	10.2	< 100	10.0	< 60

The values above are with the boiler front door removed. Values will typically increase about 0.2% once the door is reinstalled.
The values above are for altitudes up to 5,500 feet. For higher altitudes, CO₂ may be slightly lower and CO slightly higher.



Check-out/startup verification

- Verified that the U-Control is set for the correct boiler model?
 - Entered installation date and installer contact information into U-Control?
 - Boiler and heat distribution units filled with water?
 - Water chemistry verified per page 35?
 - Sentinel X100 corrosion inhibitor added and water tested to be within range?
 - Automatic air vents, if used, open one full turn?
 - Air purged from system?
 - Air purged from gas piping? Piping checked for leaks?
 - Primed condensate trap?
 - Propane orifice installed for propane firing and propane conversion label affixed to jacket?
- ▲WARNING** Ultra boilers are shipped ready to fire natural gas ONLY. Exception: The Ultra-80LP is factory-equipped to fire propane. To fire on propane, for all other models, you must follow the instructions in this manual to install the propane orifice or conversion kit, or make adjustments required, if the boiler will be connected to propane. See page 9. Failure to comply could result in severe personal injury, death or substantial property damage.
- Thermostat circuit wiring checked to ensure there are no stray voltages?
 - Followed Operating Instructions, Figure 38, page 39?
 - Burner flame and combustion verified per page 40?
 - Verified control operation for space heating and DHW (if used) per this manual?
 - Tested additional field-installed controls? — If boiler has a low water cutoff, additional high limit or other controls, tested for operation as outlined by manufacturer? (Boiler should be operating and should go off when controls are tested. Verify controls cause automatic reset lockout or manual reset lockout as desired.)
 - Set additional field-installed limit control(s) to system temperature requirements? Adjusted balancing valves and controls to provide design temperature to system?
 - For multiple zones, adjusted for correct flow in each zone?
 - Verified thermostat heat anticipator (if available) set properly?
 - Cycled boiler with thermostat (and with DHW aquastat, if installed) — Raised to highest setting and verified boiler goes through normal startup cycle? Lowered to lowest setting and verified boiler goes off?
 - Measured natural gas input? (page 40)
 - Checked incoming gas pressure by connecting manometer to gas valve ahead of boiler? (Gas pressure must be at least 5 inches w.c. for natural gas, and 4 inches w.c. for propane, with boiler operating at high fire, and no more than 13 inches w.c. with boiler operating or boiler off.)
 - Observed several operating cycles for proper operation?
 - Set room thermostat to desired room temperature (and DHW aquastat, if installed, to desired DHW storage temperature)?
 - Reviewed all instructions shipped with this boiler with owner or maintenance person?
 - Fill in **Installation certificate**, page 140.
 - Fill out the warranty registration card and send to Weil-McLain.
 - Return instructions to envelope and give to owner or place inside boiler housing.

NOTICE Fill out start-up data on the Installation and Service Certificate, page 140.



ADVANCED INSTALLATION

(Pages 44–107)

READ AND FOLLOW INSTRUCTIONS IN THE BASIC INSTALLATION SECTION FIRST. This section is supplemental information only.

This section covers multiple boiler systems and system types not covered under the BASIC section. It also includes alternative vent/air piping methods, water and gas pipe sizing guidelines and advanced, detailed information on the U-Control and boiler wiring.

ADVANCED INSTALLATION Quick view . . .

Pages	Procedure
44–47	Identify and locate boiler components <ul style="list-style-type: none"> • Read about boiler features and functions.
48–49	Modify boilers for propane operation, if required <ul style="list-style-type: none"> • All boilers except the Ultra-399 require an orifice change to operate on propane — follow instructions.
50–51	Wall mounting option <ul style="list-style-type: none"> • Wall mounting Ultra boilers requires a special kit. • Follow instructions in this section to wall mount the boiler.
52–55	Additional system piping applications <ul style="list-style-type: none"> • This section provides additional piping suggestions not covered in the BASIC section. • It includes an application with an existing indirect water heater piped as a zone.
56–57	Sizing DHW piping and circulators <ul style="list-style-type: none"> • This section provides information on boiler head loss vs flow and other information needed for sizing DHW piping.
58–64	Installing multiple Ultra boilers <ul style="list-style-type: none"> • This section provides application information and suggested piping for multiple boiler systems.
66–92	Vent / air piping alternatives <ul style="list-style-type: none"> • This section provides installation instructions for four additional vent / air piping methods not covered in the BASIC section (two sidewall configurations and two vertical configurations).
93	Gas piping <ul style="list-style-type: none"> • Size or verify sizing of gas supply lines with the information in this section.
94–98	Field wiring <ul style="list-style-type: none"> • This section includes wiring diagrams and additional wiring options available with the U-Control module.
99–107	U-Control operation and setup — advanced <ul style="list-style-type: none"> • This section provides a complete description of U-Control setting options and diagnostics.



The *Ultra* Gas-fired water boiler, Featuring *UControl* Flexibility

Ultra Models -80, -105, -155 and -230

1. Cast aluminum Nanogate coated heat exchanger

2. Heat exchanger access cover

3. Blower

The advanced blower design and air inlet silencer on Ultra boilers result in very quiet operation.

Models Ultra-80 & 105 — Air enters the boiler enclosure through the air intake adapter (18), flows through the enclosure, enters the air inlet silencer (5), then enters the blower. The blower pulls air through the silencer and pushes it into the venturi (6), where it mixes with gas before entering the burner.

Models Ultra-155 & 230 — Air enters the boiler enclosure through the air intake adapter (18), flows through the enclosure, enters the air inlet silencer (5), then enters the venturi (6). The blower pulls air and gas through the venturi and pushes the mixture into the burner.

4. Gas valves and sense lines

The automatic gas valve (4a) senses the vacuum in the venturi caused by flowing air, and allows gas to flow when power is applied. Models 80 and 105 use a sensing line (4c) from the gas valve to the blower outlet so the gas valve references the same pressure as the venturi inlet.

5. Air inlet silencer

The horn-shaped air inlet silencer significantly reduces fan noise, providing exceptionally quiet operation.

6. Venturi

When air flows through the venturi, it creates a vacuum. This vacuum pulls gas from the gas valve. So gas will only flow if air is flowing. On model 80 and 105, the gas/air mixture enters the burner after the venturi. On models 155 and 230, the gas/air mixture enters the blower before passing on to the burner.

7. Outlet water temperature dual sensor

This sensor monitors boiler outlet water temperature. The control module adjusts boiler firing rate so the outlet temperature is correct, based on boiler outlet and system supply temperatures.

8. Boiler return water temperature sensor

This sensor monitors return water temperature. The control module reduces or increases boiler input, depending on how close the return water temperature is to the outlet water temperature.

9. Electronic display & buttons

The electronic display is used to configure boiler settings and monitor boiler operation.

The buttons allow changing display mode, entering setting values, and resetting after lockout.

10. Flue pipe adapter with internal drain

11. Burner (not shown)

Made with high-grade stainless steel construction, the burner uses pre-mixed air and gas. The burner and control provide modulating firing.

12. Water outlet pipe (system supply)

13. Water return pipe (system return)

14. Gas connection pipe

15. U-Control Module

The **U-Control** Module responds to signals from the room thermostats, DHW aquastats (when used), boiler sensors (boiler return, boiler supply, system return, system supply, flue temperature, and outdoor temperature, if used). The control module automatically adjusts blower speed (and gas flow rate) to match boiler output to space heating and/or DHW heating demand.

16. Swing-away control panel assembly

The Ultra control panel is mounted to a hinged sub panel, allowing the panel to be swung forward and down for easy access to the electrical connections.

17. Air intake adapter

The air intake adapter incorporates an internal drain on models 80 and 105.

18. Electrical entrance

Knockouts are provided in the jacket top panel, allowing conduit entry directly behind the control panel or near the wall.

19. Boiler drain valve

20. Flue gas condensate drain

Connect the boiler internal condensate trap line to the heat exchanger here (parts supplied with boiler, but field installed).

21. Flue gas condensate drain connection

The condensate trap PVC fittings are field-installed, connected to the condensate trap line as shown in this manual.

22. Front door

The front door is sealed to the boiler assembly around its entire perimeter.

23. Jacket door retainer screws

Two (2) screws secure the door in place.

24. Ignition electrode/flame sensor

The burner flame is ignited by applying a high voltage to the ignition electrode. This causes a spark (from electrode to ground). After ignition, the electrode measures flame signal.

25. Flame inspection window

The quartz glass window provides a view of the burner surface and flame.

26. Flue gas dual sensor

This dual sensor monitors the flue gas exit temperature. The control module will shut down the boiler if flue gas temperature gets too hot. This protects the flue pipe and the heat exchanger from overheating.

27. ON/OFF switch



The *Ultra* Gas-fired water boiler, Featuring *UControl* Flexibility

Front view
(all models)



Ultra-80 & 105 (front door removed)

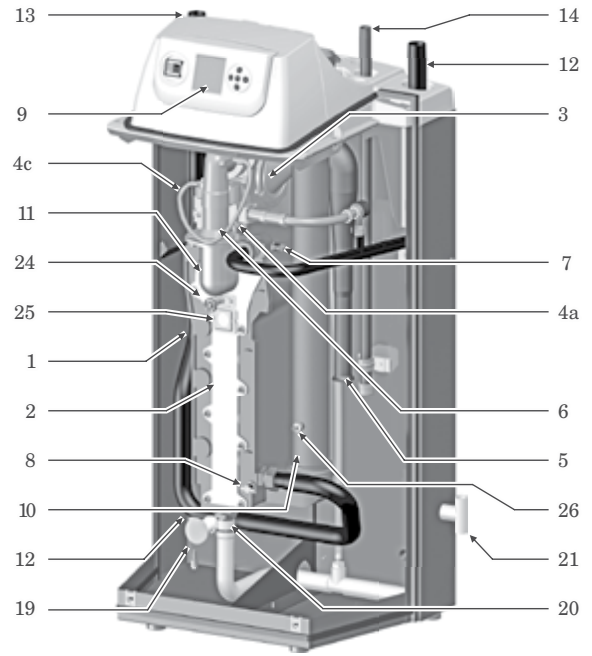

Top view
(all models)

Top is shown with top cover removed and control panel swung down for easy access to wiring terminals.

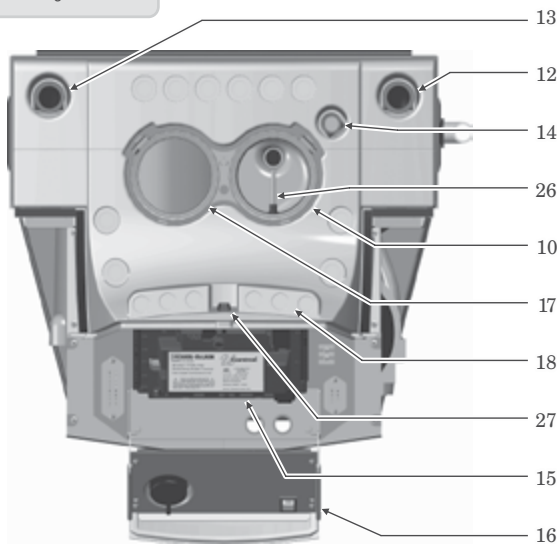

Ultra-155 & 230 (front door removed)

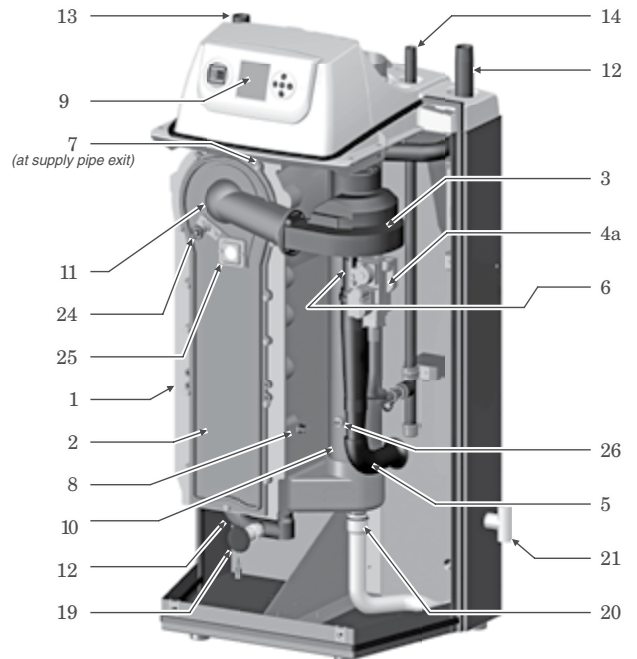

U3001

ADVANCED INSTALLATION



The *Ultra* Gas-fired water boiler, Featuring *UControl* Flexibility

Ultra Models -299 and -399

1. Cast aluminum Nanogate coated heat exchanger

2. Heat exchanger access cover

3. Blower

The advanced blower design and air inlet silencer on Ultra boilers result in very quiet operation.

Air enters the boiler enclosure through the air intake adapter (18), flows through the enclosure, enters the air inlet silencer (5), then enters the venturi (6). The blower pulls air and gas through the venturi and pushes the mixture into the burner.

4. Gas valves and sense lines

The automatic gas valve (4a) senses the vacuum in the venturi caused by flowing air, and allows gas to flow when power is applied. The manual gas valve (4b) allows shutting off the gas supply for servicing or shutdown.

5. Air inlet silencer

The horn-shaped air inlet silencer significantly reduces fan noise, providing exceptionally quiet operation.

6. Venturi

When air flows through the venturi, it creates a vacuum. This vacuum pulls gas from the gas valve. So gas will only flow if air is flowing. The gas/air mixture enters the blower before passing on to the burner.

7. Outlet water temperature dual sensor

This sensor monitors boiler outlet water temperature. The control module adjusts boiler firing rate so the outlet temperature is correct, based on boiler outlet and system supply temperatures.

8. Boiler return water temperature sensor

This sensor monitors return water temperature. The control module reduces or increases boiler input, depending on how close the return water temperature is to the outlet water temperature.

9. Electronic display & buttons

The electronic display is used to configure boiler settings and monitor boiler operation.

The buttons allow changing display mode, entering setting values, and resetting after lockout.

10. Flue pipe adapter with internal drain

11. Burner (not shown)

Made with high-grade stainless steel construction, the burner uses pre-mixed air and gas. The burner and control provide modulating firing.

12. Water outlet pipe (system supply)

13. Water return pipe (system return)

14. Gas connection pipe

15. U-Control Module

The *U-Control* Module responds to signals from the room thermostats, DHW aquastats (when used), boiler sensors (boiler return, boiler supply, system return, system supply, flue temperature, and outdoor temperature, if used). The control module automatically adjusts blower speed (and gas flow rate) to match boiler output to space heating and/or DHW heating demand.

16. Swing-away control panel assembly

The Ultra control panel is mounted to a hinged sub panel, allowing the panel to be swung forward and down for easy access to the electrical connections.

17. Air intake adapter

18. Electrical entrance

Knockouts are provided in the jacket top panel, allowing conduit entry directly behind the control panel or near the wall.

19. Boiler drain valve

20. Flue gas condensate drain

Connect the boiler internal condensate trap line to the heat exchanger here (parts supplied with boiler, but field installed).

21. Flue gas condensate drain connection

The condensate trap PVC fittings are field-installed, connected to the condensate trap line as shown in this manual.

22. Front door

The front door is sealed to the boiler assembly around its entire perimeter.

23. Jacket door retainer screws

Two (2) screws secure the door in place.

24. Ignition electrode/flame sensor

The burner flame is ignited by applying a high voltage to the ignition electrode. This causes a spark (from electrode to ground). After ignition, the electrode measures flame signal.

25. Flame inspection window

The quartz glass window provides a view of the burner surface and flame.

26. Flue gas dual sensor

This dual sensor monitors the flue gas exit temperature. The control module will shut down the boiler if flue gas temperature gets too hot. This protects the flue pipe and the heat exchanger from overheating.

27. ON/OFF switch



The *Ultra* Gas-fired water boiler, Featuring *UControl* Flexibility

Front view
(all models)



Ultra-299 (front door removed)

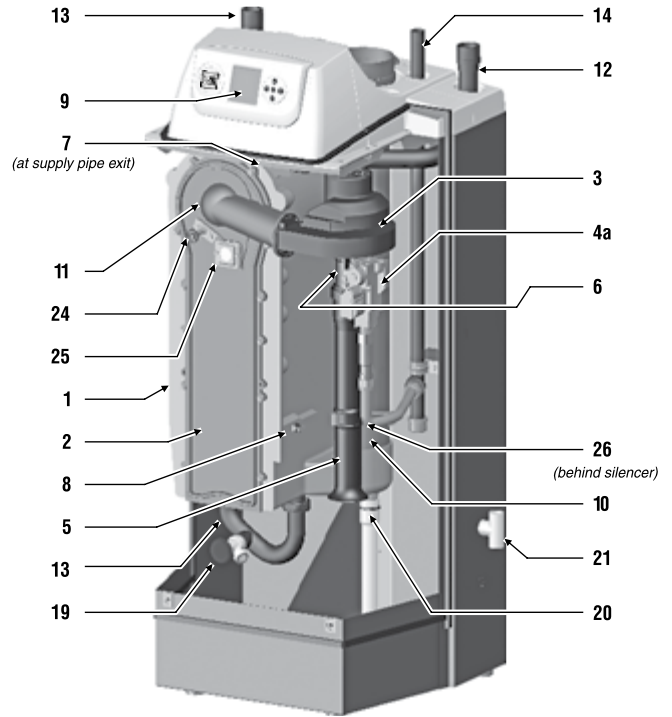

Top view
(all models)

Top is shown with top cover removed and control panel swung down for easy access to wiring terminals.

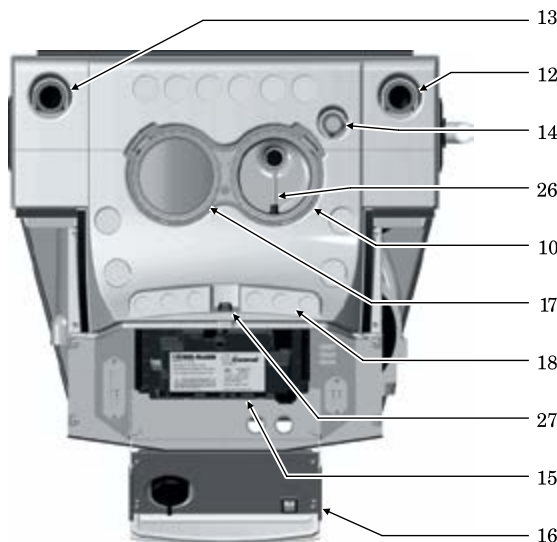

Ultra-399 (front door removed)

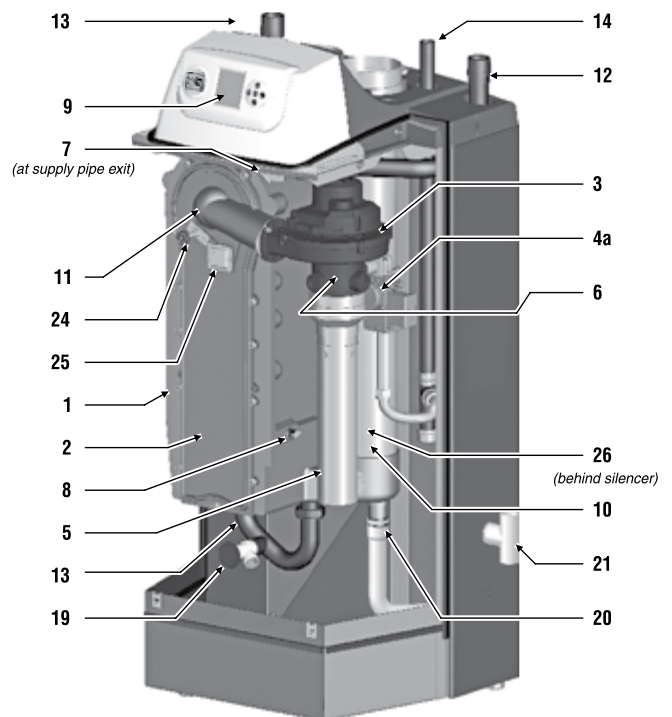

U3004

ADVANCED INSTALLATION



Prepare boiler — convert for propane

Prepare boiler for propane (when required)

Propane operation



Ultra boilers must be converted for propane operation unless specifically manufactured for propane. Propane-ready boilers have suffix “LP” after the model number. All other boilers require conversion for propane operation.

Ultra-80 natural gas boilers require installation of a burner in addition to an orifice change. **DO NOT** use the instructions in this manual for these boilers. Use only the instructions included in the special-order conversion kits.

Converting existing natural gas-fired boiler for propane — For a boiler already installed, you must turn off gas supply, turn off power and allow boiler to cool before proceeding. You must also completely test the boiler after conversion to verify performance and start up the boiler following instructions beginning on page 35 of this manual.

High altitude installations — For installations more than 5,500 feet above sea level, obtain the high altitude propane orifice kit.

Verify orifice size — See Figure 43. Verify when installing that the orifice size marking matches boiler size. Use only the special-order **high altitude** orifice for altitudes above 5,500 feet.

Failure to comply could result in severe personal injury, death or substantial property damage.

Installing propane orifice



If boiler is already installed — You must turn off electrical supply to the boiler and close the external manual gas shut-off valve to isolate the boiler during conversion. Allow the boiler to cool if it has been operating. Following conversion of an installed boiler, follow all instructions in this manual to start up the boiler and verify operation of the boiler and all system components.

1. Locate propane orifice disc from conversion kit bag.
2. Verify that the stamping on the orifice disk matches the model size (see Figure 43).
3. With the new boiler on its back, remove jacket front door by removing two (2) screws at lower front.

Figure 43 Orifice identification

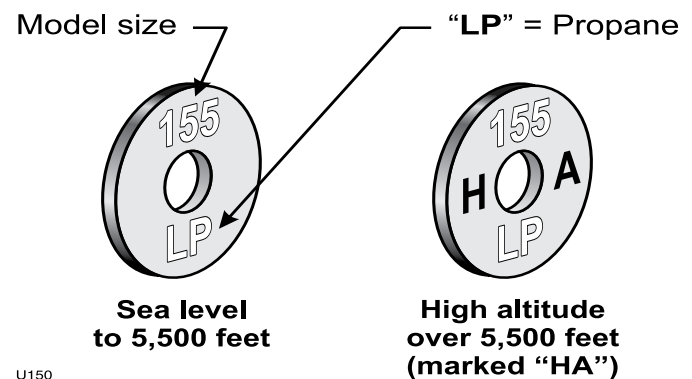

U150

Figure 44 Installing propane orifice (Ultra-105 or Ultra-80LP ONLY)

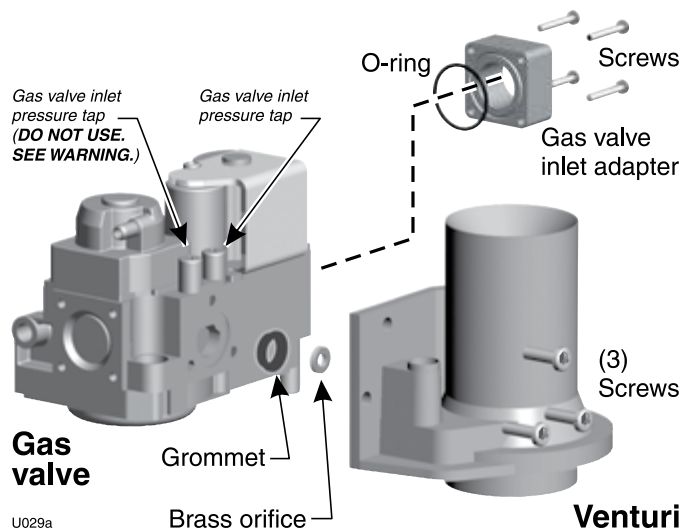

U029a

Prepare boiler — convert for propane *(continued)*

4. Lift the door away from boiler.
5. Remove the air inlet silencer from the adapter:
 - a. Models 80 and 105: See Figure 134, page 133.
 - b. Models 155 and 230: See Figure 135, page 134.
 - c. Models 299 and 399: See Figure 136, page 135.
6. Disconnect the gas valve electrical plug.
7. See Figure 43, page 48 or Figure 45. Remove the 4 screws securing gas valve inlet adapter to valve.
8. Use a 5mm wrench to remove the three Allen-head screws securing the gas valve to the venturi (Figure 43, page 48 or Figure 45).
9. Place orifice in the black rubber grommet in the side of the gas valve and secure in valve (Figure 43, page 48 or Figure 45).

⚠ DANGER See Figure 43, page 48 or Figure 45. Inspect the O-ring between the gas valve and gas valve inlet adapter whenever they are disassembled. The O-ring must be in good condition and must be installed. Failure to comply will cause a gas leak, resulting in severe personal injury or death.

10. Reposition gas valve against venturi and replace (3) Allen-head screws securing valve to venturi (Figure 43, page 48 or Figure 45).
11. See Figure 43, page 48 or Figure 45. Secure gas valve inlet adapter to gas valve with 4 screws. Make sure the plastic hose is connected from gas valve to inlet elbow on Ultra-80 and -105.

⚠ WARNING **DO NOT ATTEMPT TO MEASURE VALVE OUTLET PRESSURE.** The valve could be damaged by manometer fluid contamination. Failure to comply could result in severe personal injury, death or substantial property damage.

12. Connect gas valve electrical plug to valve terminals.
13. Re-attach the air inlet silencer.
14. After installation is complete, attach the propane conversion label (in conversion kit bag) next to the boiler rating plate.
15. Replace jacket front panel.

Figure 45 Installing propane orifice (Ultra-155, -230, & -299)

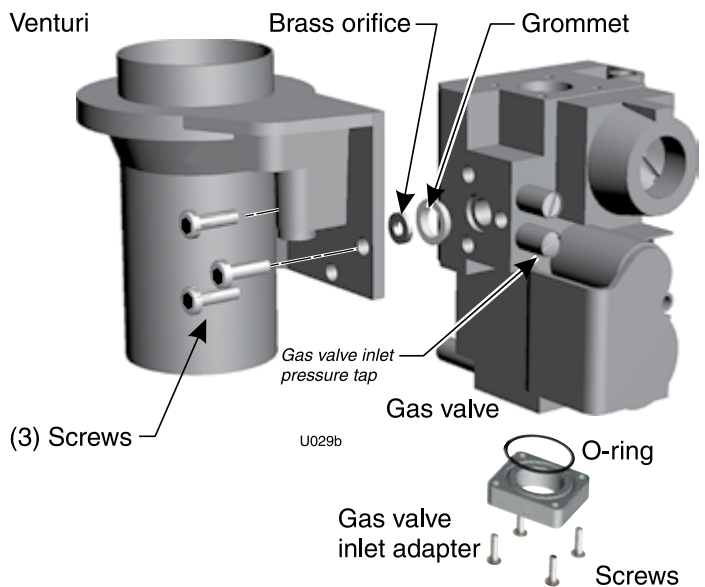

Ultra-399 boilers

⚠ DANGER Ultra-399 boilers are converted for propane by adjustment of the gas valve throttling screw. See instructions on page 41 of this manual.

Do not perform the propane conversion of an Ultra-399 boiler without using a flue gas analyzer. The proper use of a flue gas analyzer is required to determine proper gas valve settings. Improper gas valve settings can cause severe personal injury, death or substantial property damage.

Placing boiler — wall-mounting option

Wall-mounted boilers (Ultra-80 through -399)

1. The wall-mounting kit is NOT supplied as standard equipment with the boiler, and must be purchased separately. See **WARNING** below.

WARNING

Wall mount Ultra boilers only using the Weil-McLain Ultra boiler wall-mounting kit and accompanying instructions. (See Repair parts section for part number of wall mounting kit.) DO NOT use the shipping bracket to wall mount the boiler.

The wall must be vertically plumb and capable of carrying the weight of the boiler. The operating weights for wall-mountable boilers are:

Ultra-80: 139 pounds	Ultra-105: 145 pounds
Ultra-155: 181 pounds	Ultra-230: 192 pounds
Ultra-299: 229 pounds	Ultra-399: 229 pounds

Failure to comply with above and the procedure given below could result in severe personal injury, death or substantial property damage.

2. Verify kit contents:
 - a. Wall-mount bracket.
 - b. Black iron bushing, 1" x 1/8" NPT.
 - c. Lag screws, (2) 3/8" x 3" hex head.
 - d. Grommet, (1) 7/8" O. D. & grommets, (2) 1 3/8" O. D.
 - e. Automatic air vent, 1/8" NPT.
 - f. Items b through e are needed only if routing piping through bottom of enclosure (applies only for Ultra-80 through -230).
 - g. Verify all parts listed above are available before proceeding.
3. Stud spacing: Bracket holes are spaced for studs on 16-inch centers. For other stud spacing, provide secure, solid mounting surface on which to attach the boiler wall-mounting bracket.
4. Wood stud wall: Install bracket with lag screws (3/8" x 3") included in kit, only into the studs.
5. Metal stud wall: Secure bracket to studs with 3/16-inch toggle bolts and 3/16-inch flat washers (not included with kit).
6. **DO NOT** attempt to attach the wall mount bracket using anchors or any means other than directly securing to the wall studs (or equivalent wood structure if studs are not on 16-inch centers).
7. The boiler bracket must engage with the wall-mount bracket. Make sure the brackets are not just resting edge to edge.
8. Mount the boiler on the wall following these instructions. Perform all procedures given in the Boiler Manual on pages 1 through 9 before mounting the boiler.

WARNING

The boiler is heavy. Use caution not to drop the boiler or cause bodily injury while lifting and handling. Verify that the boiler is securely attached to prevent possibility of boiler falling after installation.

Figure 46 Install wall-mount bracket

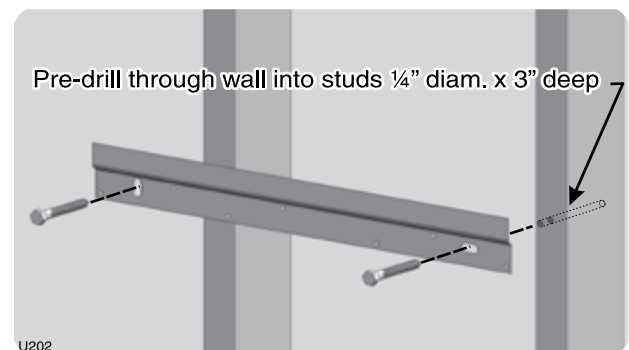
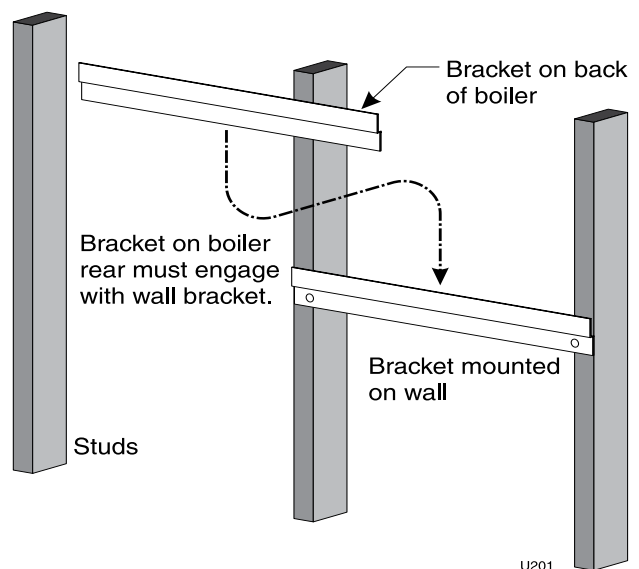

Figure 47 Place boiler on wall-mount bracket



Placing boiler — wall-mounting option *(continued)*

Prepare boiler for wall mounting

1. Remove the jacket front panel. This will simplify lifting and handling the boiler when mounting.
2. When piping will be routed out the top of the boiler, no special preparation is needed other than that given in this manual.

Install wall-mount bracket

1. Locate studs.
2. Place the wall-mount bracket on the wall, using a level to align correctly.
3. Place the bracket so the mounting slots are centered over the studs.
4. Level the bracket and trace the outline of the screw slots with a pencil.
5. Remove bracket and drill holes 1/4" diameter by 3 inches deep, centered on the screw slot outlines. (For metal stud walls, using 3/16" toggle bolts, drill required clearance holes.)
6. See Figure 47, page 50. Position bracket on wall. Insert and loosely tighten the two lag screws (or toggle bolts for metal studs).
7. Level the bracket. Then tighten screws securely. For drywall or plaster lathe installations, avoid tightening so much that brackets dig into wall surface.

Place boiler on bracket

1. Measure 30 3/4 inches below the bottom edge of the wall-mount bracket for Ultra-80 to -230 (35 5/8" for Ultra-299/399). Strike a line or place a piece of masking tape on the wall with its top edge even with the 30-inch mark. (This line, or tape, will indicate whether the boiler has been properly seated onto the wall-mount bracket.)
2. Obtain assistance to lift the boiler into position:
 - a. Lift the boiler high enough that its rear bracket will be above the wall-mount bracket.
 - b. Let the rear of the boiler slide against the lag screw heads as you lower the boiler into place.
 - c. When the brackets are engaged correctly, the bottom of the boiler enclosure will be at or near the pencil line, or tape, you applied in step 1.
 - d. If the boiler does not slide down close to the mark, or tape, adjust until the brackets properly engage.



Install water piping — advanced

Zoning with zone valves

(alternate to piping shown in Figure 5, page 12)

High-flow-rate/high-head-loss DHW circuits

1. For applications requiring DHW circuit flow rates higher than allowable for the boiler, or for high pressure-drop coil-type DHW tanks, connect the piping as in Figure 48. The DHW water only flows through the secondary circuit connector piping. NOTE: Make sure to size the connector piping (Figure 48, item 23) to handle the total flow it must handle.
2. Connect boiler to system as shown in Figure 48 when zone valve zoning. The primary/secondary piping shown ensures the boiler loop will have sufficient flow. It also avoids applying the high head of the boiler circulator to the zone valves.

CAUTION Use **at least the MINIMUM** pipe size shown in Figure 48 on all boiler loop piping (connecting boiler to and from the primary/secondary connection, item 21). Use **only primary/secondary piping as shown**. Failure to follow these guidelines could result in system problems.

3. When using a closed-type expansion tank, connect the expansion tank and make-up water piping as shown in Figure 4, page 11.
4. Connect DHW (domestic hot water) piping to indirect storage water heater as shown.

NOTICE By default, the U-Control Module turns off space heating during DHW heating (if DHW input is priority 1). The boiler circulator will turn off, preventing hot water from circulating to the system (optional timeout setting can be used to override). The flow/check valve shown on the boiler outlet piping prevents gravity circulation in the boiler loop during DHW heating.

NOTICE Overriding the Outdoor Reset function by setting control to DHW mode when system is intended for space heating may violate **Section 303 of the 2007 Energy Act**. See page 137 for compliance information and exemptions.

5. Controlling the system circulator and boiler circulator
 - a. You will have to set up the U-Control to operate both the boiler circulator and the DHW circulator during DHW operation. The system circulator should be off during DHW heating. Read the instructions on U-Control operation and setup, beginning on page 32.

Figure 48 Zone valve zoning plus optional DHW piping

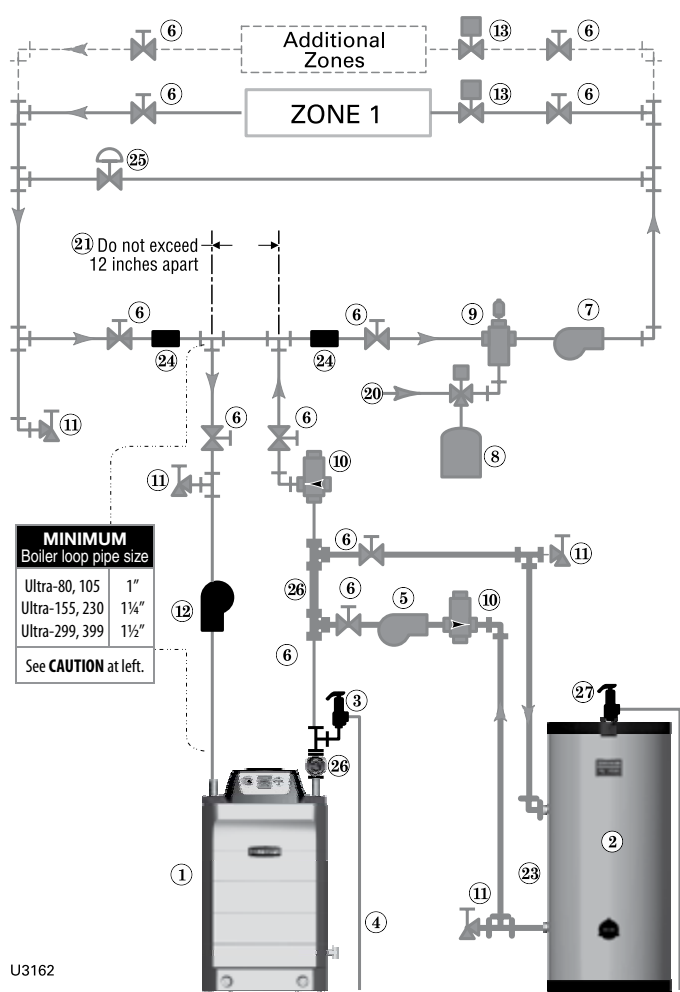

U3162

Legend — Figure 48

- | | |
|---|---|
| <ol style="list-style-type: none"> 1 Ultra boiler 2 Indirect water heater (DHW), if used 3 Boiler relief valve (see page 9 for piping details) 4 Relief valve discharge piping (see page 9 for details) 5 DHW circulator (see page 56 for suggested sizing) 6 Isolation valves 7 System circulator (see information above for wiring) 8 Diaphragm (or bladder) type expansion tank (see page 56 for piping of closed-type expansion tank, if used) 9 Air separator [with automatic air vent only on systems using diaphragm (or bladder) type expansion tank] 10 Flow/check valves 11 Purge/drain valves | <ol style="list-style-type: none"> 12 Boiler circulator 13 Zone valves, typical 20 Make-up water supply 21 Primary/secondary connection (tees no more than 12 inches apart) 23 DHW supply/return 24 Strap system supply and return sensors to lines as shown, at least 6 pipe diameters (but no more than 3 feet) from boiler connection tees. 25 Systems using high-head pumps may require a bypass pressure regulator to prevent damage to control valves. 26 Temperature/Pressure gauge 27 DHW relief valve, if used <p>■ Items supplied with boiler
■ Items supplied by others</p> |
|---|---|



Install water piping — advanced *(continued)*

Example system with DHW as a zone, zoning with circulators

1. Connect boiler to system as shown in Figure 49 when circulator zoning. The boiler circulator cannot be used for a zone. It must supply only the boiler loop. Also see the information on page 10 for suggested piping and sizing.

CAUTION Use **at least the MINIMUM** pipe size shown in Figure 49 on all boiler loop piping (connecting boiler to and from the primary/secondary connection, item 21). **Use only primary/secondary piping as shown.** Failure to follow these guidelines could result in system problems.

2. Install a separate circulator for each zone.
3. **DO NOT** use a closed-type tank with a AQUA PLUS water heater in the system. The automatic air vent required on the water heater will deplete air in the system, causing the expansion tank to waterlog. Use only a diaphragm- or bladder-type tank, suitable for automatic air vent applications.
4. In this example, the AQUA PLUS 60 DHW tank is piped as a zone in the system, with piping connections to the tank in accordance with the AQUA PLUS manual.
5. Wiring to the U-Control
 - a. Priority 1 = AQUA PLUS 60 (zone 1): wire AQUA PLUS 60 aquastat terminals to U-Control P11, pins 4 and 5. Wire DHW circulator, A, to U-Control P2, terminals 1, 4 and 7 (H, N, G).
 - b. Wire zone pumps B and C to a two-zone circulator relay.
 - c. Priority 2 = finned-tube baseboard (zones 2 and 3): wire circulator relay end switch 1 to U-Control P15, pins 1 and 2.
6. Make sure to set Priority 1 to DHW system, not DHW direct.

NOTICE Overriding the Outdoor Reset function by setting control to DHW mode when system is intended for space heating may violate **Section 303 of the 2007 Energy Act**. See page 137 for compliance information and exemptions.

7. Controlling the system circulator and boiler circulator
 - a. You will have to set up the U-Control to operate both the boiler circulator and the DHW circulator during DHW operation. Read the instructions on U-Control operation and setup, beginning on page 32.

Figure 49 Circulator zoning plus optional DHW piping

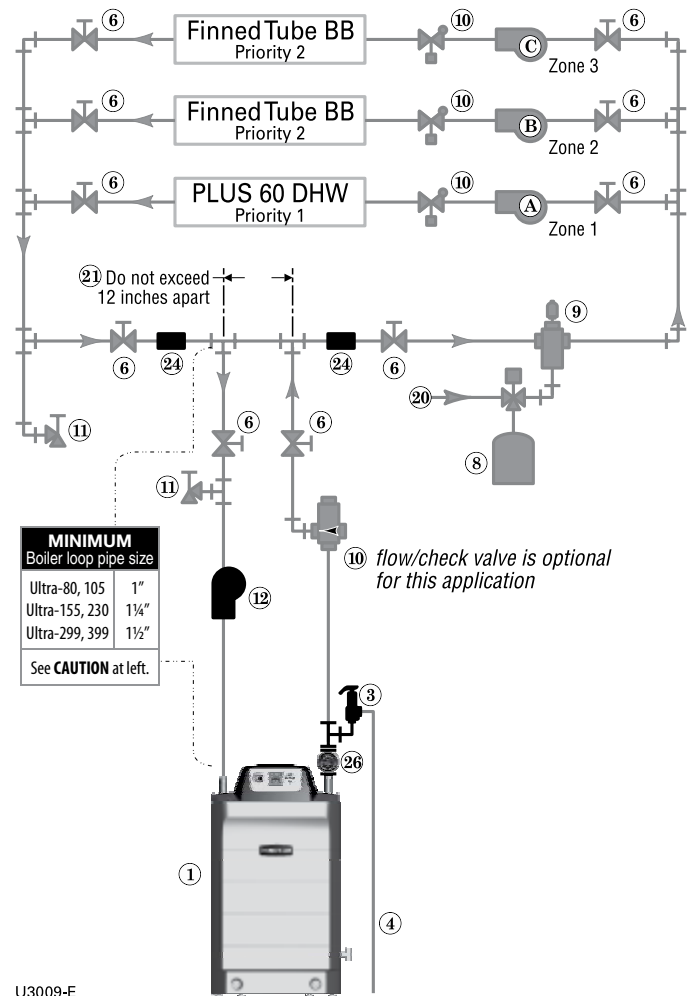

ADVANCED INSTALLATION

Legend — Figure 49

- | | |
|---|---|
| <ol style="list-style-type: none"> 1 Ultra boiler 2 Indirect water heater (DHW), if used 3 Boiler relief valve (see page 9 for piping details) 4 Relief valve discharge piping (see page 9 for details) 6 Isolation valves 8 Diaphragm (or bladder) type expansion tank (see page 56 for piping of closed-type expansion tank, if used) 9 Air separator [with automatic air vent only on systems using diaphragm (or bladder) type expansion tank] | <ol style="list-style-type: none"> 10 Flow/check valves 11 Purge/drain valves 12 Boiler circulator 20 Make-up water supply 21 Primary/secondary connection (tees no more than 12 inches apart) 24 Strap system supply and return sensors to lines as shown, at least 6 pipe diameters (but no more than 3 feet) from boiler connection tees. 26 Temperature/Pressure gauge <p>■ Items supplied with boiler</p> <p>■ Items supplied by others</p> |
|---|---|



Install water piping — advanced *(continued)*

Radiant heating applications

1. The Ultra boiler is ideal for use in radiant heating. The Ultra boiler's unique heat exchanger design allows it to work well even in condensing mode. So there is no need to regulate boiler return water temperature in radiant heating applications.
2. Connect boiler to system as shown in Figure 50 for typical radiant heating applications. The primary/secondary piping shown ensures the boiler loop will have sufficient flow. Size the system piping and circulator to provide the flow and pressure drop needed for the radiant system.

CAUTION Use **at least the MINIMUM** pipe size shown in Figure 50 on all boiler loop piping (connecting boiler to and from the primary/secondary connection, item 21). **Use only primary/secondary piping as shown.** Failure to follow these guidelines could result in system problems.

3. Adding the recommended high limit control (Figure 50, item 22) can help ensure supply water temperature will not exceed the maximum allowable for the radiant system. Wire this limit control in either the manual reset or automatic reset external limit circuit of the U-Control.
4. When using a closed-type expansion tank, connect the expansion tank and make-up water piping as shown in Figure 4, page 11.
5. Connect DHW (domestic hot water) piping to indirect storage water heater as shown.

NOTICE By default, the U-Control Module turns off space heating during DHW heating (if DHW input is priority 1). The boiler circulator will turn off, preventing hot water from circulating to the system (optional timeout setting can be used to override). The flow/check valve shown on the boiler outlet piping prevents gravity circulation in the boiler loop during DHW heating.

NOTICE Overriding the Outdoor Reset function by setting control to DHW mode when system is intended for space heating may violate **Section 303 of the 2007 Energy Act.** See page 137 for compliance information and exemptions.

6. Controlling the circulators
 - a. The U-Control can control up to three circulators (boiler circulator and two others). Refer to Field wiring, beginning on page 30, for instructions on wiring to circulators.

Figure 50 Typical radiant heating system piping plus optional DHW

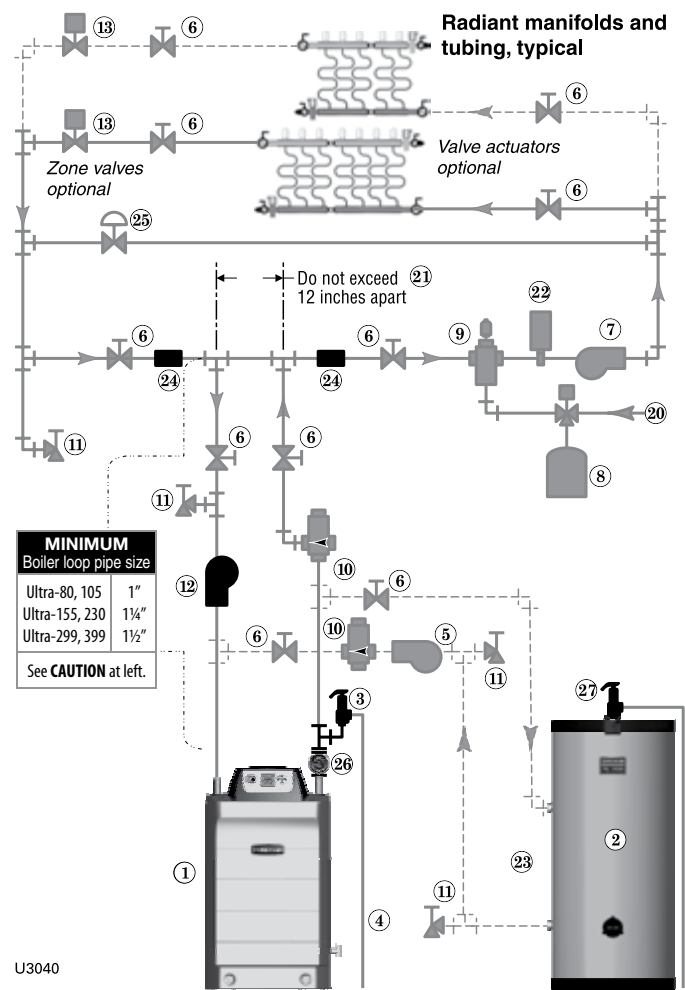

- b. The factory default settings are: DHW circulator as Circulator 1, boiler circulator as Circulator 2. See Field wiring instructions, beginning on page 30, for details.

Legend — Figure 50

1 Ultra boiler	13 Zone valves, when used (zoning may also be done using manifold-mounted valve actuators)
2 Indirect water heater (DHW), if used	20 Make-up water supply
3 Boiler relief valve (see page 9 for piping details)	21 Primary/secondary connection (tees no more than 12 inches apart)
4 Relief valve discharge piping (see page 9 for details)	22 Optional high limit temperature control, set to protect radiant tubing
5 DHW circulator (see page 56 for suggested sizing)	23 DHW supply/return
6 Isolation valves	24 Strap system supply and return sensors to lines as shown, at least 6 pipe diameters (but no more than 3 feet) from boiler connection tees.
7 System circulator (see information above for wiring)	25 Systems using high-head pumps may require a bypass pressure regulator to prevent damage to control valves.
8 Diaphragm (or bladder) type expansion tank (see page 56 for piping of closed-type expansion tank, if used)	26 Temperature/Pressure gauge
9 Air separator [with automatic air vent only on systems using diaphragm (or bladder) type expansion tank]	27 DHW relief valve, if used
10 Flow/check valves	■ Items supplied with boiler
11 Purge/drain valves	■ Items supplied by others
12 Boiler circulator	



Install water piping — advanced *(continued)*

Chilled water systems

1. Install boiler so that chilled medium is piped in parallel with the heating boiler. Use appropriate valves to prevent chilled medium from entering boiler. See Figure 51 for typical installation of balancing valve and check valve.

CAUTION Use **at least** the **MINIMUM** pipe size shown in Figure 51 on all boiler loop piping (connecting boiler to and from the primary/secondary connection, item 21). **Use only primary/secondary piping as shown.** Failure to follow these guidelines could result in system problems.

2. The space heating system may be zoned with circulators if a separate circulator is supplied for the chilled water loop.

NOTICE If antifreeze is used in the system, consider the effects of antifreeze on circulator sizing and DHW performance. Some local codes may require double-wall DHW heat exchanger design.

WARNING Chilled medium, if used, is piped in parallel with heating boiler as shown in Figure 51. Use appropriate valves to prevent chilled medium from entering boiler.

If boiler is connected to heating coils located in air handling units where they can be exposed to refrigerated air, use flow control valves or other automatic means to prevent gravity circulation during cooling cycle.

NOTICE By default, the U-Control Module turns off space heating during DHW heating (if DHW input is priority 1). The boiler circulator will turn off, preventing hot water from circulating to the system (optional timeout setting can be used to override). The flow/check valve shown on the boiler outlet piping prevents gravity circulation in the boiler loop during DHW heating.

NOTICE Overriding the Outdoor Reset function by setting control to DHW mode when system is intended for space heating may violate **Section 303 of the 2007 Energy Act**. See page 137 for compliance information and exemptions.

3. Controlling the circulators
 - a. The U-Control can control up to three circulators (boiler circulator and two others). Refer to Field wiring, beginning on page 30, for instructions on wiring to circulators.

Figure 51 Chilled water system plus optional DHW piping

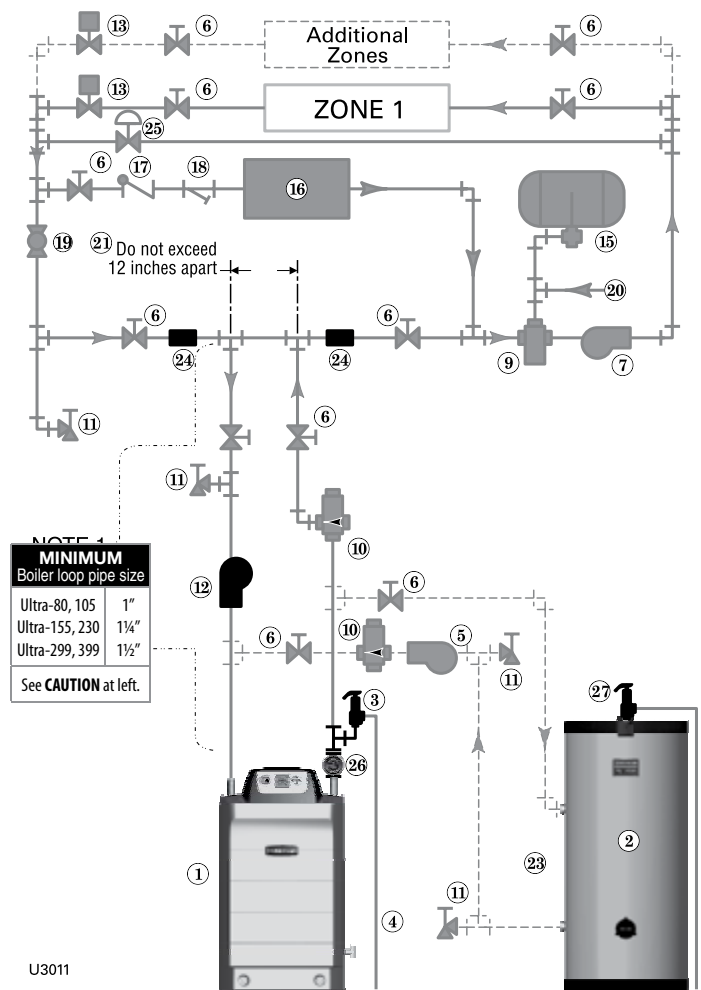

NOTE 1
MINIMUM
Boiler loop pipe size

Ultra-80, 105	1"
Ultra-155, 230	1 1/4"
Ultra-299, 399	1 1/2"

See CAUTION at left.

- b. The factory default settings are: DHW circulator as Circulator 1, boiler circulator as Circulator 2. See Field wiring instructions, beginning on page 30, for details.

Legend — Figure 51

1 Ultra boiler	16 Water chiller
2 Indirect water heater (DHW), if used	17 Check valve
3 Boiler relief valve (see page 9 for piping details)	18 Strainer
4 Relief valve discharge piping (see page 9 for details)	19 Balancing valve
5 DHW circulator (see page 56 for suggested sizing)	20 Make-up water supply
6 Isolation valves	21 Primary/secondary connection (tees no more than 12 inches apart)
7 System circulator (see information above for wiring)	23 DHW supply/return
8 Diaphragm (or bladder) type expansion tank (see page 56 for piping of closed-type expansion tank, if used)	24 Strap system supply and return sensors to lines as shown, at least 6 pipe diameters (but no more than 3 feet) from boiler connection tees.
9 Air separator [with automatic air vent only on systems using diaphragm (or bladder) type expansion tank]	25 Systems using high-head pumps may require a bypass pressure regulator to prevent damage to control valves.
10 Flow/check valves	26 Temperature/Pressure gauge
11 Purge/drain valves	27 DHW relief valve, if used
12 Boiler circulator	■ Items supplied with boiler
13 Zone valves, typical	■ Items supplied by others
15 Closed-type expansion tank	



Sizing direct-connected DHW piping

Direct-connected DHW piping

NOTICE For **Weil-McLain AQUA PLUS water heaters**, refer to the AQUA PLUS water heater manual for application information. Also see quick-select information on page 14. The information here is for other water heater designs.

NOTICE When using the Ultra boiler for dedicated DHW applications, use the circulator supplied with the boiler (007 for Ultra-80/105; 0014 for Ultra-155/230/299; 0013 for Ultra-399) to circulate to the water heater, except where higher flow rates may be required for the heater used. Use the following method to select a circulator for the water heater on combined space heating/DHW systems.

- To pipe the DHW tank and boiler, follow the suggested piping diagrams beginning on page 12.
- Figure 55, page 57 shows the pump curves for typical DHW circulators. Use these curves along with boiler pressure drop data from Figure 54, page 57 to size the DHW piping and circulator.
- Procedure to select a DHW circulator:

Step 1:

From the water heater manufacturer's data, find:

- Required boiler water flow rate, GPM, at 190°F.
- Pressure drop across the water heater at this flow rate, in feet water column (this is H3 in the formula below).

Step 2:

Find your boiler model in Figure 54, page 57. Select a flow rate in the Flow rate column just larger than the required boiler water flow rate from Step 1.

Step 3:

Read across the row selected to find the boiler pressure drop, H1, and the pressure drop in the piping, H2. Make sure to use the copper pipe size given in column 3 when piping the water heater.

Step 4:

Add the pressure drop across the water heater, from Step 1, to the values of H1 and H2 for total head loss.

$$H_{total} = H1 + H2 + H3$$

Step 5:

Select a circulator that can deliver the required flow rate, gpm, against the total head loss found in Step 4.

Example:

Consider an Ultra-155 used with a water heater that requires a flow of 12 gpm with boiler water at 190°F. The water heater is to be piped as in Figure 52.

From the example water heater manufacturer's data, the head loss across the water heater at 12 gpm is 5.5 feet water column.

Read down the first column of Figure 54, page 57 for the Ultra-155 until you find a flow rate just larger than the required 12 gpm. You'll find a value of 13 gpm in the third row. At 13 gpm, with an Ultra-155, the recommended pipe size is 1¼ inch. From the table, the head losses are:

H1 = 13.3 feet H2 = 3.9 feet
 H3 = 5.5 feet (from water heater manufacturer's data)
 H_{total} = 13.3 + 3.9 + 5.5 = 22.7 feet.

The closest circulator selection (from Figure 55, page 57) that can deliver 12 gpm at 22.7 feet head is either a Taco 1400 (top chart) or a Taco 0013 (bottom chart).

Note that, if the water heater were piped as in Figure 53, then H1 would be 0, so total head loss would be H2 + H3, or 9.4 feet (3.9 + 5.5). A Taco 0010 would handle the load if piped this way.

NOTICE

See previous pages in this manual for piping details not shown below. For DHW piping as shown below, use sizing information in Figure 54, page 57.

Figure 52 DHW piping direct-connected across the boiler

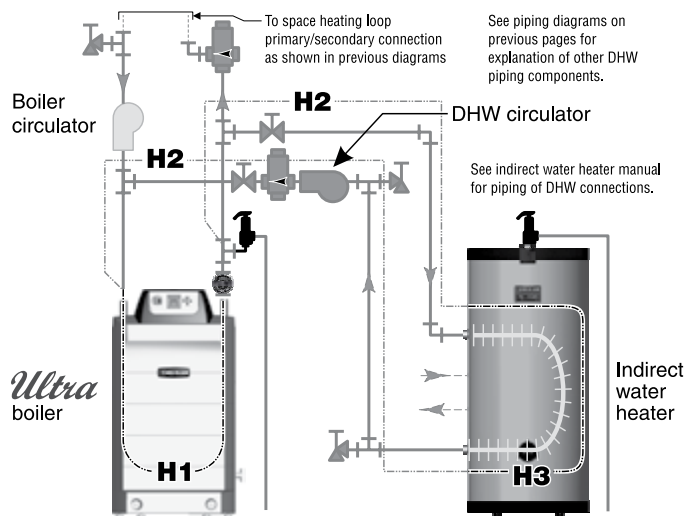

H1 = Head loss through boiler H3 = Head loss through water heater
 H2 = Head loss through DHW piping

U3046

Figure 53 DHW piping as a secondary circuit — for high-flow-rate applications

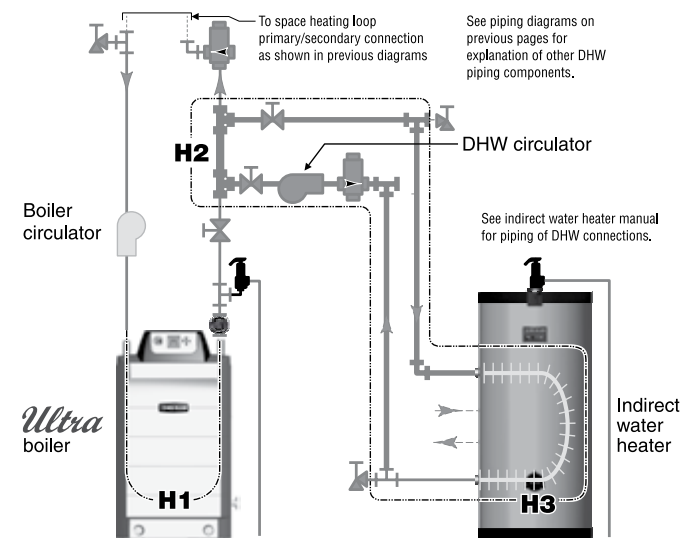

H1 = 0 (no DHW flow through boiler) H3 = Head loss through water heater
 H2 = Head loss through DHW piping

U3046a



Sizing direct-connected DHW piping *(continued)*

Figure 54 Pipe sizing and head losses for DHW applications (*H1=Ultra boiler head loss; H2= piping head loss*)

Flow rate	Temp rise	Pipe size	H1	H2
GPM	°F	Inches	Boiler head loss Feet w.c.	Piping head loss Feet w.c.
Ultra-80 (71,000 Btuh output)				
7	20	1	6.6	2.7
9	16	1	11.6	4.2
10	14	1¼	14.6	2.5
Ultra-105 (94,000 Btuh output)				
7	27	1	7.0	2.7
9	21	1	11.2	4.2
10	19	1¼	13.6	2.5
13	14	1¼	22.2	3.9
Ultra-155 (139,000 Btuh output)				
9	31	1¼	6.2	2.1
10.0	28	1¼	7.7	2.5
13	21	1¼	13.3	3.9
16	17	1¼	20.5	5.7
Ultra-230 (207,000 Btuh output)				
13	32	1¼	9.4	3.9
16	26	1¼	13.7	5.7
21	20	1½	22.0	2.9
Ultra-299 (279,000 Btuh output)				
18	31	1½	6.6	2.2
22	25	1½	9.5	3.1
29	19	2	17.4	2.9
Ultra-399 (365,000 Btuh output)				
22	34	1½	9.5	3.1
29	25	2	15.5	2.9
36	20	2	22.8	4.3

Figure 55 Pump curves for typical circulators suggested for DHW loop

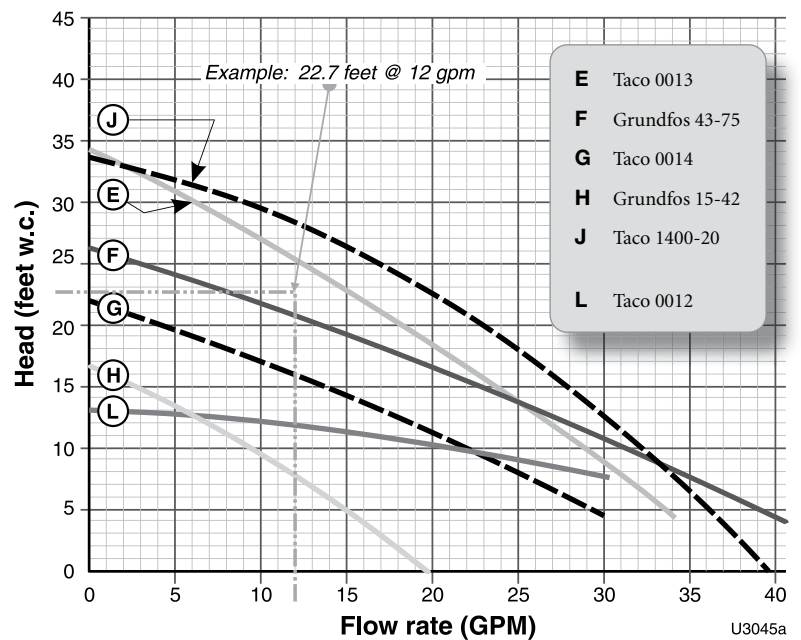
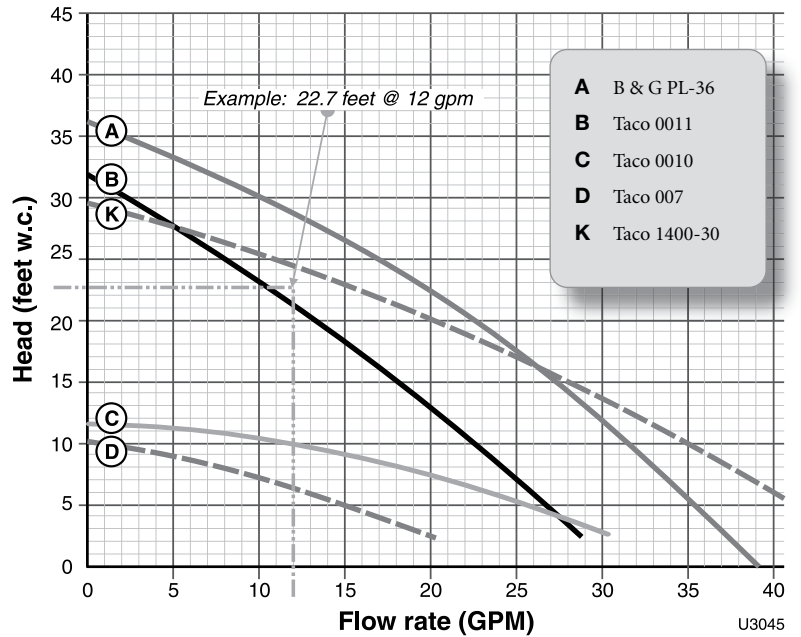

ADVANCED INSTALLATION

Multiple boiler installations

Placing multiple boilers

1. Locate multiple boilers in boiler room according to:
 - a. Figure 56 (side-to-side), or
 - b. Figure 57 (back-to-back).
 - c. Figure 58 (wall mounting).
2. Provide indicated clearances around boilers for access and servicing. If recommended dimensions are not possible, provide at least the minimum clearances given on page 5. Also follow local codes.
3. Construct boiler foundation if boiler room floor is uneven or if there is a danger of flooding. Size foundation to allow for clearance and spacing dimensions shown in the illustrations at right.
4. Chalk line boiler locations on foundation or boiler room floor.
5. Uncrate, assemble and mount boilers according to instructions in this manual.
6. Provide clearance for installation of venting, air piping, gas piping, expansion tank, primary circulator and other accessories.

Wall mounting (Ultra Models 80 - 399)

1. Ultra boilers may be wall mounted, following the instructions on page 50. (See Repair parts section for part number of wall mounting kit.)
2. When wall mounting boilers, provide approximately 6 inches between boilers for easy removal of boiler jacket door. See Figure 58.
3. Follow all applicable codes regarding piping, electrical connections and clearances.
4. When wall mounting boilers, verify the wall construction is suitable for the structural load. See page 50 for details.

Figure 56 Side-to-side mounting of multiple Ultra boilers

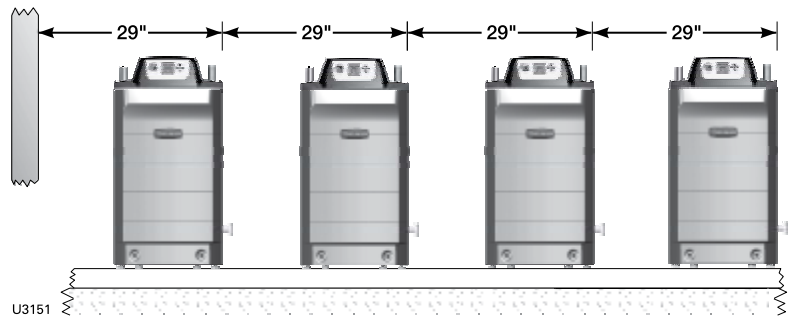

Figure 57 Back-to-back installation of multiple Ultra boilers

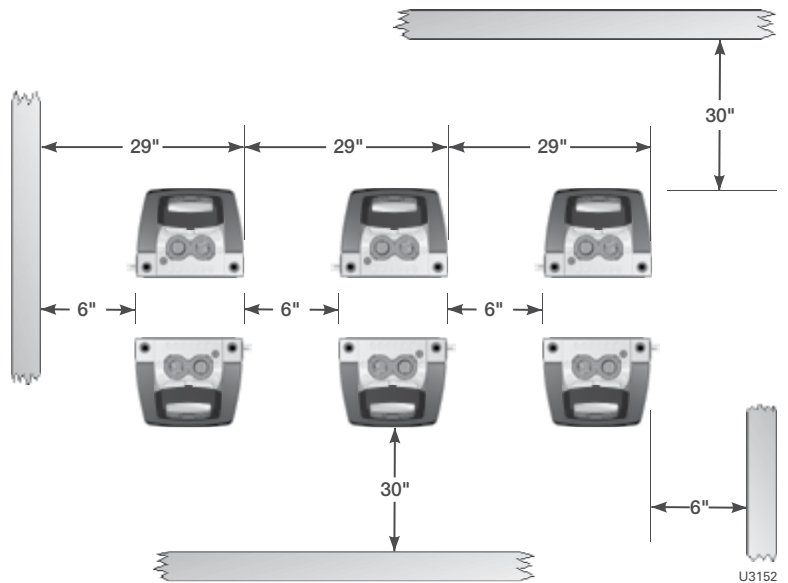
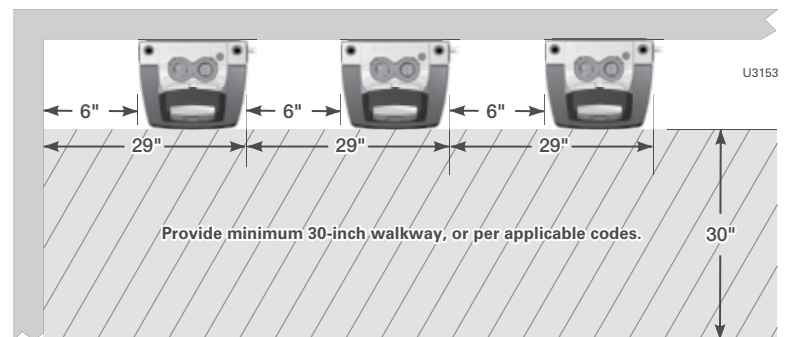

Figure 58 Wall mounting multiple Ultra boilers



Multiple boiler installations *(continued)*

Manifolded combustion air option

1. Multiple Ultra boilers can use a common combustion air manifold.
 - a. See Figure 139, page 138 for minimum cross sectional area of combined air ducts.
 - b. Provide minimum clearance to adjacent vents and grade/snow line as shown in Figure 59.
 - c. Provide minimum free area in duct (adjusted for louver restriction) of **1 square inch per 2,000 Btuh** total boiler input.
 - d. If combustion air damper is used, wire to boilers to prevent operation except after damper has opened.

WARNING ONLY air piping can be combined. DO NOT use combined vent piping. Flue gas leakage and boiler component damage can occur. Failure to comply could result in severe personal injury, death or substantial property damage.

Figure 59 Manifolded combustion air option

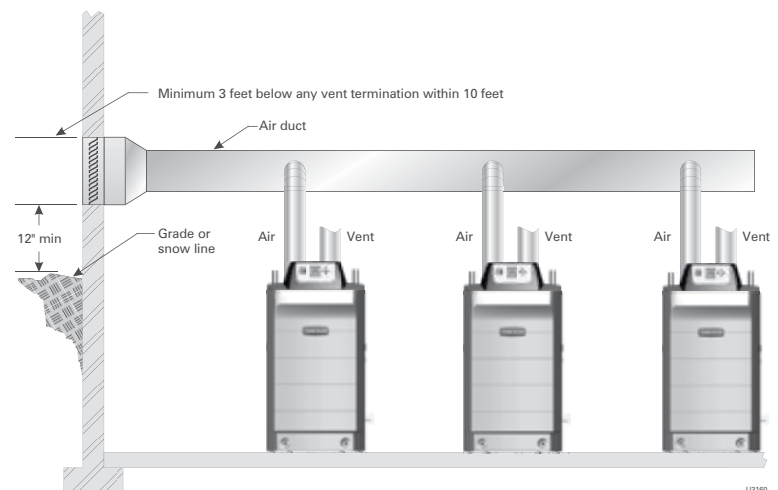

WARNING DO NOT use common venting — the manifold option is only for combustion air — all vent pipes must be routed and terminated individually as described in this manual.

See Figure 139, page 138 for minimum cross sectional area of combined air ducts.

OR

Calculate required cross section (for area in square inches):

$$\text{MIN. AREA} = \text{TOTAL MBH INPUT DIVIDED BY 2}$$

Example: A multiple boiler system with (6) Ultra-155 boilers has a total input of $6 \times 155 = 930$ MBH (930,000 Btuh). The required duct cross sectional area is:

$$\text{MIN. AREA} = 930 \text{ DIVIDED BY 2} = 465 \text{ sq. inches}$$



Multiple boiler installations *(continued)*

Easy-Fit® piping installation

1. Main header and Easy-Fit® Manifold pipe sizing.
 - a. New system — See page 10.
 - b. Replacing boilers in an existing system — Without reducing size, connect system supply and return lines. Install tees or crosses for Easy-Fit® manifolds as shown in Figure 60 or Figure 61. Size manifolds to handle total connected boiler output as shown.
2. Provide connections in main header for Easy-Fit® manifolds as close as possible to the midpoint of multiple boilers.
 - a. Use tees for four or less boilers, as in Figure 60.
 - b. Use either tees (Figure 60) or crosses (Figure 61) for five or more boilers.
3. Manifold placement:
 - a. To alternate spacing for supply and return lines to boilers, reverse the short-end and long-end of the manifolds as shown in Figure 60 and Figure 61.
 - b. Return manifold must be on the return side of the main and supply manifold must be on the supply side of the main. Drawings in this manual show flow in system main from right to left. For system flowing left to right, reverse the locations of the manifolds accordingly.
4. Connect from Easy-Fit® manifold branches to boiler supply and return connections using copper or steel pipe, sized for the required flow rate.
5. Provide a flow/check valve in the supply piping of each boiler as shown in piping diagrams in this manual. Install an isolation valve on the supply and return of each boiler as shown. Some local codes may require the use of individual water level controls and limits on each boiler when isolation valves are installed.
6. Install main system air eliminator and primary circulator in supply piping as shown in piping diagrams. Place expansion tank on suction side of system circulator as shown.
7. Install system accessories as shown in drawings.
8. Piping recommendation drawings:
 - a. Figure 60 and Figure 61 show details of Easy-Fit® manifolds.
 - b. Figure 62, page 61 is a schematic piping drawing showing the locations of typical boiler piping and system piping, including limits and other devices often required by local codes.
 - c. Figure 63, page 62 and Figure 64, page 63 are three-dimensional piping drawings of typical multiple boiler installation.
 - d. Figure 65, page 64 shows recommended piping when an isolating heat exchanger is needed.
9. If desired, other primary/secondary piping arrangements can be used.

NOTICE When using isolation valves on each boiler, some codes may require providing a low water control and additional limit for each boiler. Consult local codes to determine if omission of the individual boiler isolation valves may allow the use of a single water level control and additional limit for the entire multiple boiler system. **The U-Control module proves water level using a dual temperature sensor installed in the Ultra heat exchanger.** This will satisfy some code requirements for low water cutoff protection.

Maximum connected load per manifold:	
2-inch manifold	450 MBH
3-inch manifold	1400 MBH
4-inch manifold	2900 MBH

Figure 60 Single-sided EZ-Fit Header connection

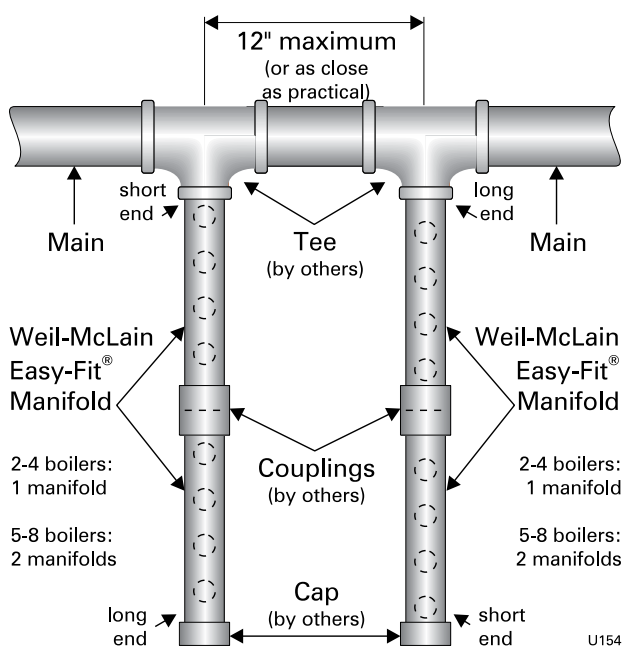
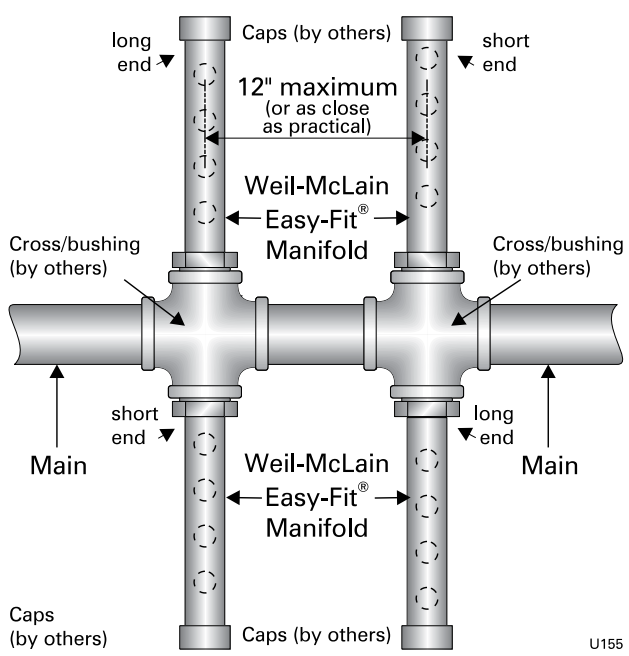
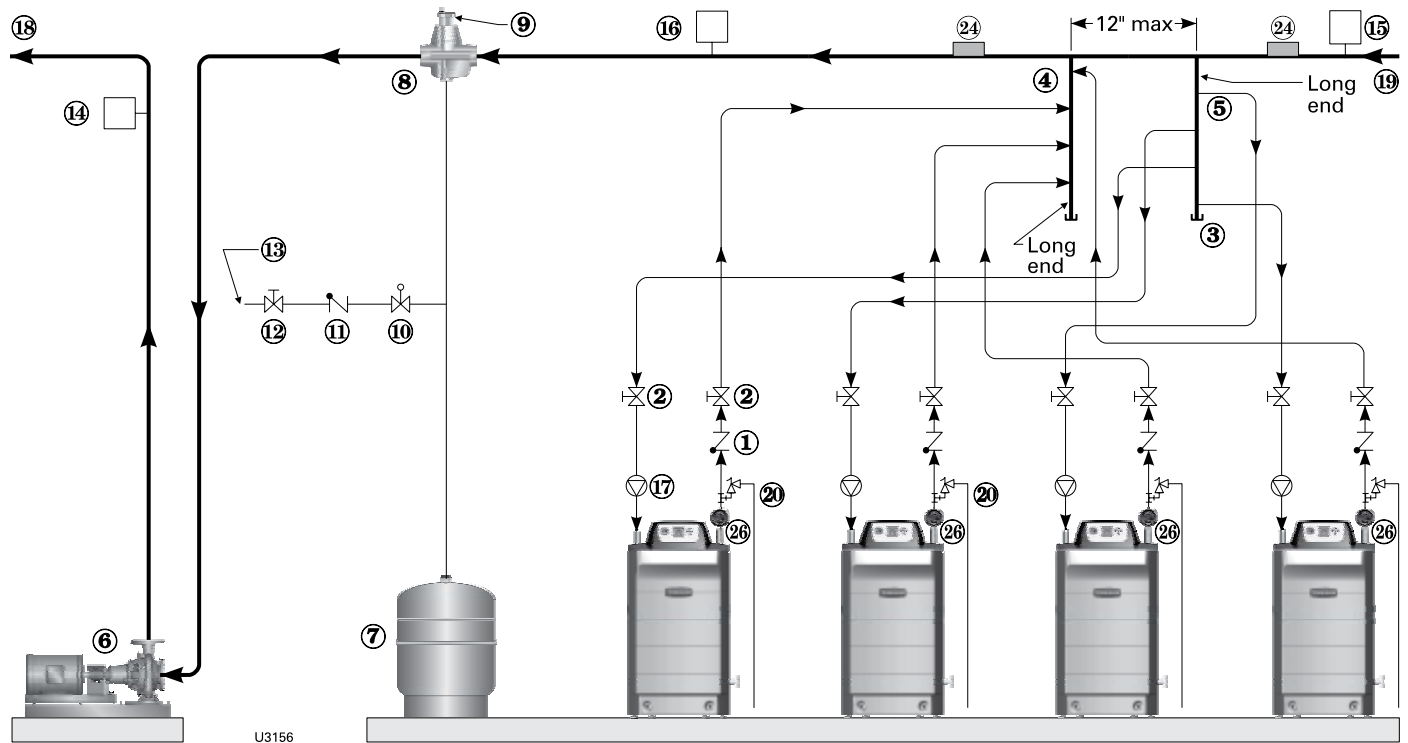

Figure 61 Double-sided EZ-Fit Header connection



Multiple boiler installations (continued)

Figure 62 Piping schematic — typical piping for multiple Ultra boilers, using Weil-McLain Easy-Fit manifolds



Legend — Figure 62

- | | |
|---|---|
| 1 Flow/check valve (each boiler) | 11 Check valve or backflow preventer, as required by applicable codes |
| 2 Isolation valves (when used) | 12 Isolation valve |
| 3 Cap | 13 Cold water supply |
| 4 Easy-Fit® Manifold (supply) — layout and size per page 60 | 14 Supply water temperature control (when used) |
| 5 Easy-Fit® Manifold (return) — layout and size per page 60 | 15 Low water cutoff (when used) (place above primary header) |
| 6 Primary circulator | 16 Water flow switch (when used) |
| 7 Expansion tank (diaphragm type) | 17 Boiler circulator (each boiler) |
| 8 System air eliminator | 18 System supply |
| 9 System automatic air vent | 19 System return |
| 10 Pressure reducing valve | 20 Boiler relief valve and discharge piping, installed per Ultra Boiler Manual |
| | 24 Strap system supply and return sensors to lines as shown, at least 6 pipe diameters (but no more than 3 feet) from boiler connection tees. |
| | 26 Temperature/pressure gauge |

Multiple boiler installations *(continued)*

Figure 63 Piping layout — typical piping for multiple Ultra boilers, using Weil-McLain Easy-Fit manifolds (2-boiler system)

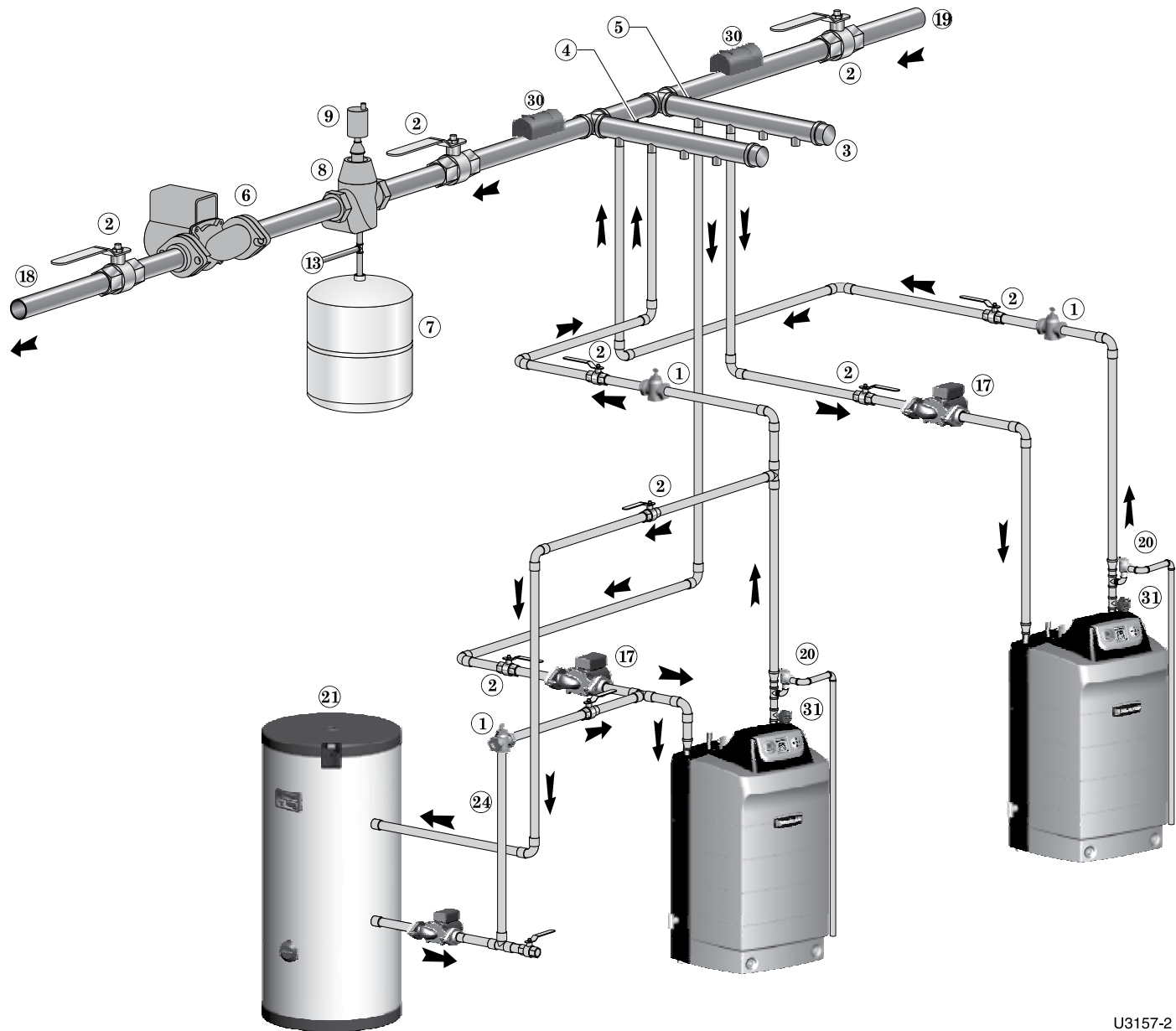

U3157-2

Legend — Figure 63

- | | |
|---|--|
| <ul style="list-style-type: none"> 1 Flow/check valve (each boiler) 2 Isolation valves (when used) 3 Caps 4 Easy-Fit® Manifold (supply) — layout and size per page 60 5 Easy-Fit® Manifold (return) — layout and size per page 60 6 Primary circulator 7 Expansion tank (diaphragm type) 8 System air eliminator 9 System automatic air vent 13 Cold water supply 17 Boiler circulator (each boiler) | <ul style="list-style-type: none"> 18 System supply 19 System return 20 Boiler relief valve and discharge piping, installed per Ultra Boiler Manual 21 Indirect-fired storage water heaters (Weil-McLain AQUA PLUS shown) — Example is shown connected to one boiler of the system. Preferably, use the last boiler in the lead/lag sequence and set its Priority to DHW Direct so it will switch to DHW firing and turn off its boiler circulator on a call for domestic water heating. 24 DHW boiler-side circulator 30 Strap system supply and return sensors to lines as shown, at least 6 pipe diameters (but no more than 3 feet) from boiler connection tees. 32 Temperature/pressure gauge |
|---|--|



Multiple boiler installations *(continued)*

Figure 64 Piping layout — typical piping for multiple Ultra boilers, with DHW storage heaters (4-boiler system)

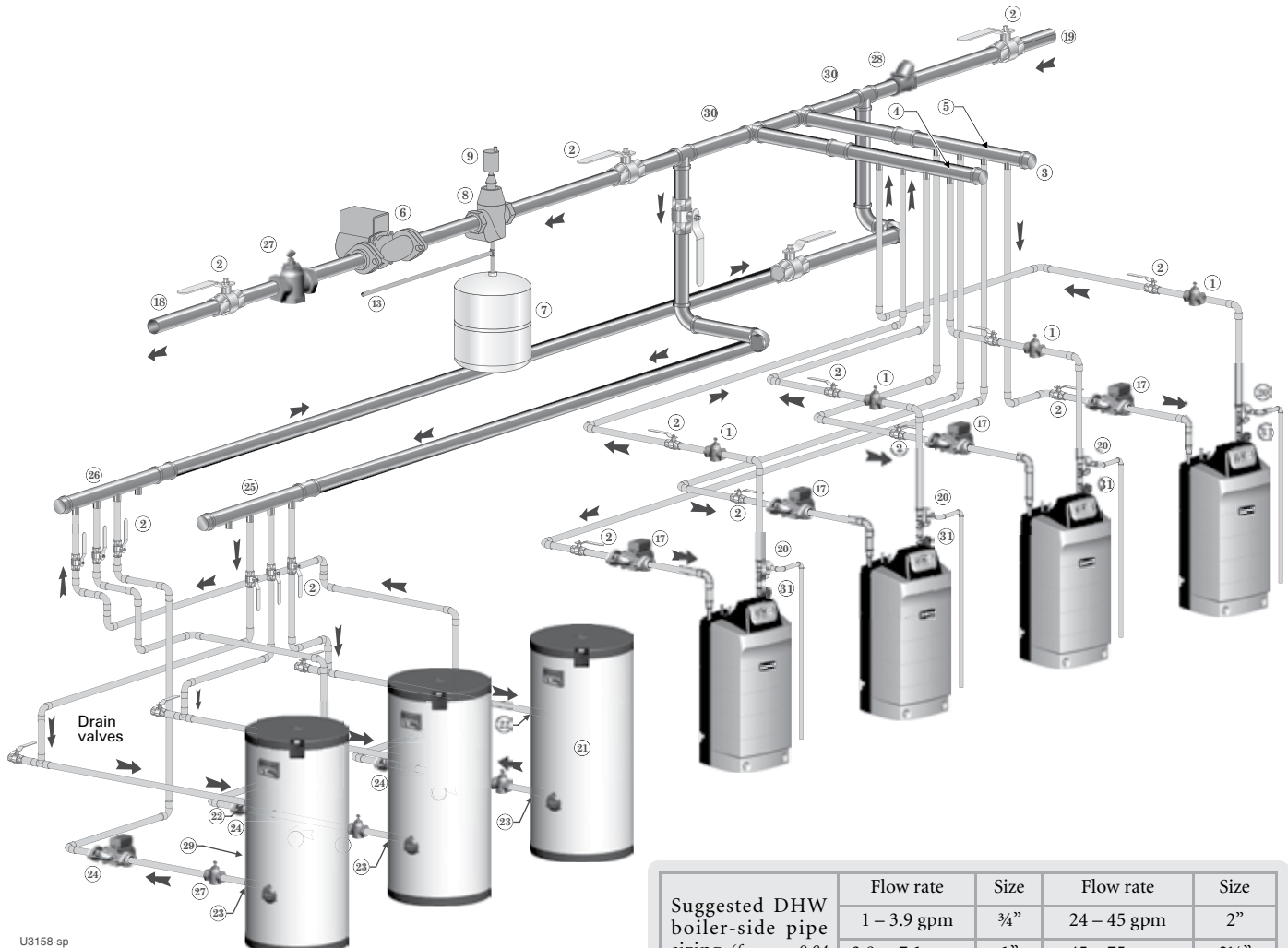

Suggested DHW boiler-side pipe sizing (for max 0.04 feet head loss per foot of total equivalent length, TEL)	Flow rate	Size	Flow rate	Size
	1 – 3.9 gpm	¾"	24 – 45 gpm	2"
	3.9 – 7.1 gpm	1"	45 – 75 gpm	2½"
	7.1 – 16 gpm	1¼"	75 – 140 gpm	3"
	16 – 24 gpm	1½"	140 – 290 gpm	4"

Legend — Figure 64

- | | |
|---|---|
| <ul style="list-style-type: none"> 1 Flow/check valve (each boiler) 2 Isolation valves (when used) 3 Caps 4 Easy-Fit® Manifold (supply) — layout and size per page 60 5 Easy-Fit® Manifold (return) — layout and size per page 60 6 Primary circulator 7 Expansion tank (diaphragm type) 8 System air eliminator 9 System automatic air vent 13 Cold water supply 17 Boiler circulator (each boiler) 18 System supply 19 System return 20 Boiler relief valve and discharge piping, installed per Ultra Boiler Manual | <ul style="list-style-type: none"> 21 Indirect-fired storage water heaters (Weil-McLain AQUA PLUS shown) — Example is shown with reverse-return boiler-side piping using a single circulator. Alternate: each water heater could have its own circulator. 22 Boiler water inlet 23 Boiler water outlet 24 DHW boiler-side circulators 25 DHW boiler-side supply Easy-Fit® Manifold 26 DHW boiler-side return Easy-Fit® Manifold 27 Flow/check valves (to prevent induced or gravity flow in heating system or DHW piping) 28 Check valve to prevent heat migration in heating system. 29 See water heater manual for DHW piping — The DHW piping must also be manifolded together since the boiler-side piping is manifolded. If DHW heaters supply separate DHW circuits, provide an individual circulator for each water heater, and control each circulator by its water heater's aquastat. 30 Strap system supply and return sensors to lines as shown, at least 6 pipe diameters (but no more than 3 feet) from boiler connection tees. 31 Temperature/pressure gauge |
|---|---|

NOTICE This piping is suggested only. The layout above should be controlled with a boiler sequencing panel that provides DHW operation as well. Wire the heating system circulator to operate only on call for heat. Alternatively, use the boiler sequencing panel to provide domestic priority by disabling the heating system circulator any time there is a DHW call for heat. The boiler circulators, item 17, must operate on any call for heat, whether heating system or DHW. Offset the DHW boiler-side supply and return manifolds as shown so the total run of pipe and fittings to each of the water heaters is approximately equal.

ADVANCED INSTALLATION



Multiple boiler installations (continued)

Figure 65 Piping layout — typical piping for multiple Ultra boilers, using isolation exchanger

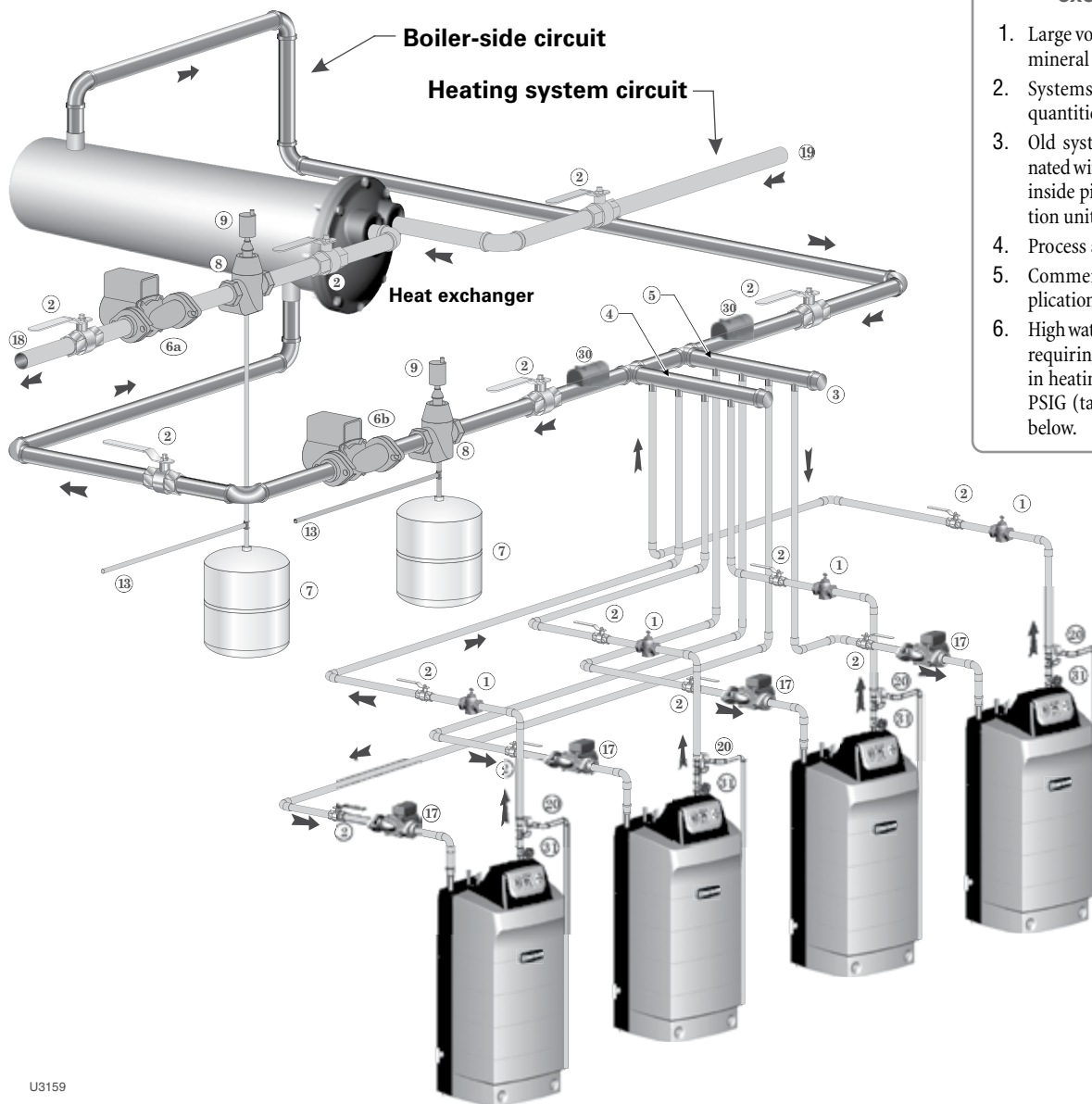

Use isolation heat exchanger for:

1. Large volume systems with high mineral content in water.
2. Systems exposed to untreated quantities of makeup water.
3. Old systems severely contaminated with scale and rust buildup inside piping and heat distribution units.
4. Process applications.
5. Commercial service water applications.
6. High water pressure applications, requiring pressure relief setting in heating system more than 30 PSIG (tall buildings). See notes below.

U3159

Legend — Figure 65

1 Flow/check valve (each boiler)	9 System automatic air vent
2 Isolation valves (when used)	13 Cold water supply connections
3 Cap	17 Boiler circulator (each boiler)
4 Easy-Fit® Manifold (supply) — layout and size per page 60	18 Heating system supply
5 Easy-Fit® Manifold (return) — layout and size per page 60	19 Heating system return
6a Heating system circulator (exchanger tube-side)	20 Boiler relief valve and discharge piping, installed per Ultra Boiler Manual
6b Heat exchanger shell-side circulator	30 Strap system supply and return sensors to lines as shown, at least 6 pipe diameters (but no more than 3 feet) from boiler connection tees.
7 Expansion tanks (diaphragm type)	31 Temperature/pressure gauge
8 System air eliminator	

Notes:

1. Contact heat exchanger manufacturer for heat exchanger shell-side and tube-side piping and circulator requirements. Tube-side flow and temperatures must meet heating system requirements.
2. Contact heat exchanger manufacturer for sizing heat exchanger.
3. Heat exchanger shell-side circuit requires its own expansion tank as shown.
4. Heating system circuit requires its own expansion tank, as shown, plus its own relief valve set to protect heating system and heat exchanger piping and components.
5. When individual isolation valves are used, individual boiler and level controls may be required.

Venting/air piping — Massachusetts installations

Instructions for the Commonwealth of Massachusetts

- (a) For all sidewall horizontally-vented gas-fueled equipment installed in every dwelling, building or structure used in whole or in part for residential purposes, including those owned or operated by the Commonwealth and where the side wall exhaust vent termination is less than seven (7) feet above finished grade in the area of the venting, including but not limited to decks and porches, the following requirements shall be satisfied:
- 1. INSTALLATION OF CARBON MONOXIDE DETECTORS.** At the time of installation of the side wall horizontally-vented gas-fueled equipment, the installing plumber or gas fitter shall observe that a hard-wired carbon monoxide detector with an alarm and battery back-up is installed on the floor level where the gas equipment is to be installed. In addition, the installing plumber or gas fitter shall observe that a battery-operated or hard-wired carbon monoxide detector with an alarm is installed on each additional level of the dwelling, building or structure served by the side wall horizontally-vented gas-fueled equipment. It shall be the responsibility of the property owner to secure the services of qualified licensed professionals for the installation of hard-wired carbon monoxide detectors
 - a. In the event that the side wall horizontally-vented gas-fueled equipment is installed in a crawl space or an attic, the hard-wired carbon monoxide detector with alarm and battery back-up may be installed on the next adjacent floor level.
 - b. In the event that the requirements of this subdivision can not be met at the time of completion of installation, the owner shall have a period of thirty (30) days to comply with the above requirements; provided, however, that during said thirty (30) day period, a battery-operated carbon monoxide detector with an alarm shall be installed.
 - 2. APPROVED CARBON MONOXIDE DETECTORS.** Each carbon monoxide detector as required in accordance with the above provisions shall comply with NFPA 720 and be ANSI/UL 2034 listed and IAS certified.
 - 3. SIGNAGE.** A metal or plastic identification plate shall be permanently mounted to the exterior of the building at a minimum height of eight (8) feet above grade directly in line with the exhaust vent terminal for the horizontally-vented gas-fueled heating appliance or equipment. The sign shall read, in print size no less than one-half (1/2) inch in size, "GAS VENT DIRECTLY BELOW. KEEP CLEAR OF ALL OBSTRUCTIONS."
 - 4. INSPECTION.** The state or local gas inspector of the side wall horizontally-vented gas-fueled equipment shall not approve the installation unless, upon inspection, the inspector observes carbon monoxide detectors and signage installed in accordance with the provisions of 248 CMR 5.08(2)(a) 1 through 4.
- (b) **EXEMPTIONS:** The following equipment is exempt from 248 CMR 5.08(2)(a)1 through 4:
1. The equipment listed in Chapter 10 entitled "Equipment Not Required To Be Vented" in the most current edition of NFPA 54 as adopted by the Board; and
 2. Product Approved side wall horizontally-vented gas-fueled equipment installed in a room or structure separate from the dwelling, building or structure used in whole or in part for residential purposes.
- (c) **MANUFACTURER REQUIREMENTS — GAS EQUIPMENT VENTING SYSTEM PROVIDED.** When the manufacturer of Product Approved side wall horizontally-vented gas equipment provides a venting system design or venting system components with the equipment, the instructions provided by the manufacturer for installation of the equipment and the venting system shall include:
1. Detailed instructions for the installation of the venting system design or the venting system components; and
 2. A complete parts list for the venting system design or venting system.
- (d) **MANUFACTURER REQUIREMENTS — GAS EQUIPMENT VENTING SYSTEM NOT PROVIDED.** When the manufacturer of a Product Approved side wall horizontally-vented gas-fueled equipment does not provide the parts for venting the flue gases, but identifies "special venting systems", the following requirements shall be satisfied by the manufacturer:
1. The referenced "special venting system" instructions shall be included with the appliance or equipment installation instructions; and
 2. The "special venting systems" shall be Product Approved by the Board, and the instructions for that system shall include a parts list and detailed installation instructions.
- (e) A copy of all installation instructions for all Product Approved side wall horizontally-vented gas-fueled equipment, all venting instructions, all parts lists for venting instructions, and/or all venting design instructions shall remain with the appliance or equipment at the completion of the installation.



Vent/air piping — options

Vent and air pipe termination options

1. Vent and air piping must terminate out the sidewall or through the roof of the building, using only one of the methods described in this manual.
2. Sidewall options (see Figure 12, page 18, left side):
 - a. TOP: Weil-McLain termination cap (kit included with boiler) — see page 67 for instructions.
 - b. MIDDLE: Concentric PVC pipe (requires special kit, page 129).
 - c. BOTTOM: Separate air pipe and vent pipe.
3. Vertical options (Figure 12, page 18, right side):
 - a. TOP: Concentric PVC pipe (requires special kit, page 129).
 - b. BOTTOM: Separate air pipe and vent pipe.

Vent and air pipe diameters

1. Vent and air pipe diameters can be as specified in Figure 12, page 18.

Vent and air pipe minimum length

1. Vent pipe and air pipe must each be **at least 2 feet long**, with 2 elbows if sidewall venting or 1 elbow if vertical venting.

Vent and air pipe installation sequence

- Step 1** Install the boiler.
- Step 2** Determine the termination method — sidewall or vertical, concentric or separate pipes, etc.
- Step 3** Determine proper location for wall or roof penetration for each termination.
- Step 4** Install termination assembly as described in this manual.
- Step 5** Install air and vent piping from boiler to termination.
- Step 6** Install pipe supports and brackets as required.

Figure 66 Sidewall and vertical termination options

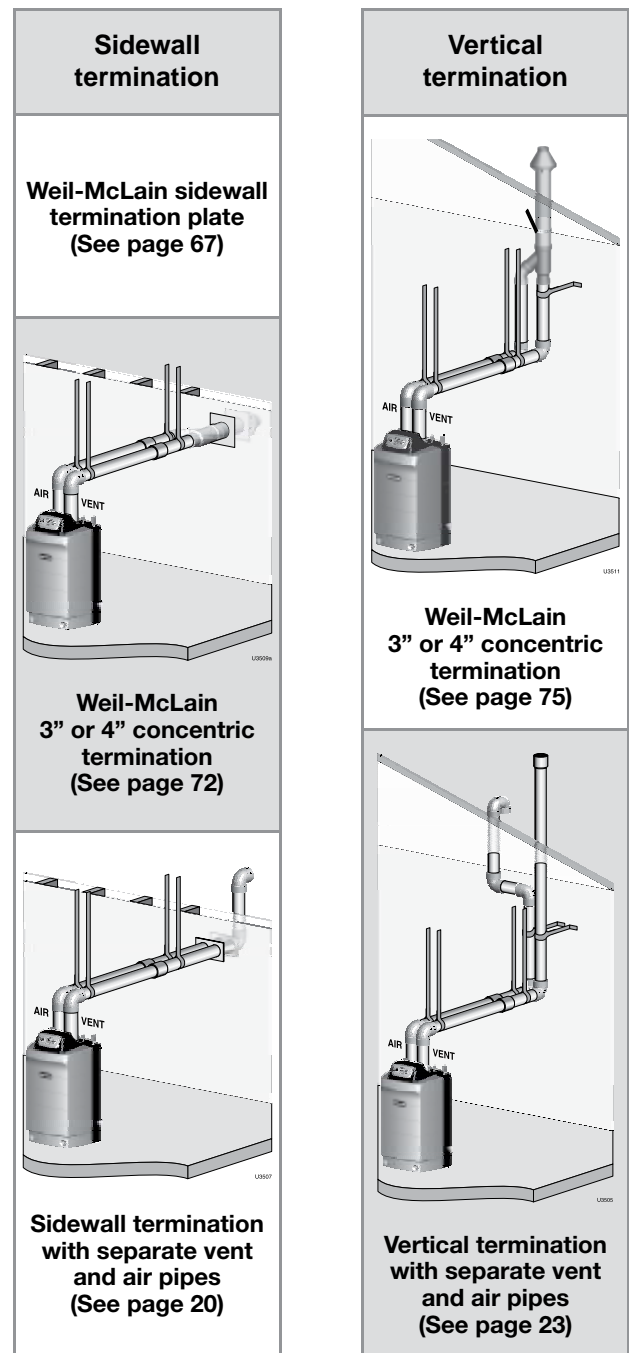



Sidewall vent/air termination: *Weil-McLain cap*

Vent and air pipe termination options

1. This section covers sidewall termination using the Weil-McLain sidewall vent cap.
 - a. Models 80, 105 and 155 requires a 3-inch pipe size kit.
 - b. Models 230, 299 and 399 requires a 4-inch pipe size kit.
 - c. The Weil-McLain sidewall vent/air cap kit includes the termination cap, inside and outside wall plates, and mounting hardware to secure the plates.
2. For other termination options and parts required, see page 66.

Vent and air pipe requirements

1. Vent and air pipe diameters can be as specified in Figure 67.

Figure 67 Vent and air pipe requirements

Ultra models	2" Plastic	3" Plastic or 3" AL29-4C	4" Plastic or 4" AL29-4C
-80 & -105	Yes	Yes	No
-155	No	Yes	No
-230	No	Yes	Yes
299/399	No	No	Yes

Use appropriate **adapters** where needed — Ultra-80 through -155 require 3.5 inch outside diameter pipe at the boiler vent and air connections. Ultra-230, -299 and -399 boilers require 4.5 inch outside diameter pipe at the boiler vent and air connections.

Vent and air pipe minimum length

1. Vent pipe and air pipe must each be at least 2 feet long, with two (2) elbows if sidewall venting or 1 elbow if vertical venting.

Vent and air pipe maximum length

1. See Figure 69, page 68 for maximum length of vent and air piping using the Weil-McLain sidewall vent cap.

NOTICE

Other vent/air piping alternatives — see information beginning on page 66. Options include other termination fittings and vertical terminations.

Vent and air pipe installation sequence

- Step 7** Install the boiler.
- Step 8** Determine the termination method — sidewall or vertical, concentric or separate pipes, etc.
- Step 9** Determine proper location for wall or roof penetration for each termination.
- Step 10** Install termination assembly as described in this manual.
- Step 11** Install air and vent piping from boiler to termination.
- Step 12** Install pipe supports and brackets as required.

Figure 68 Vent and air termination options

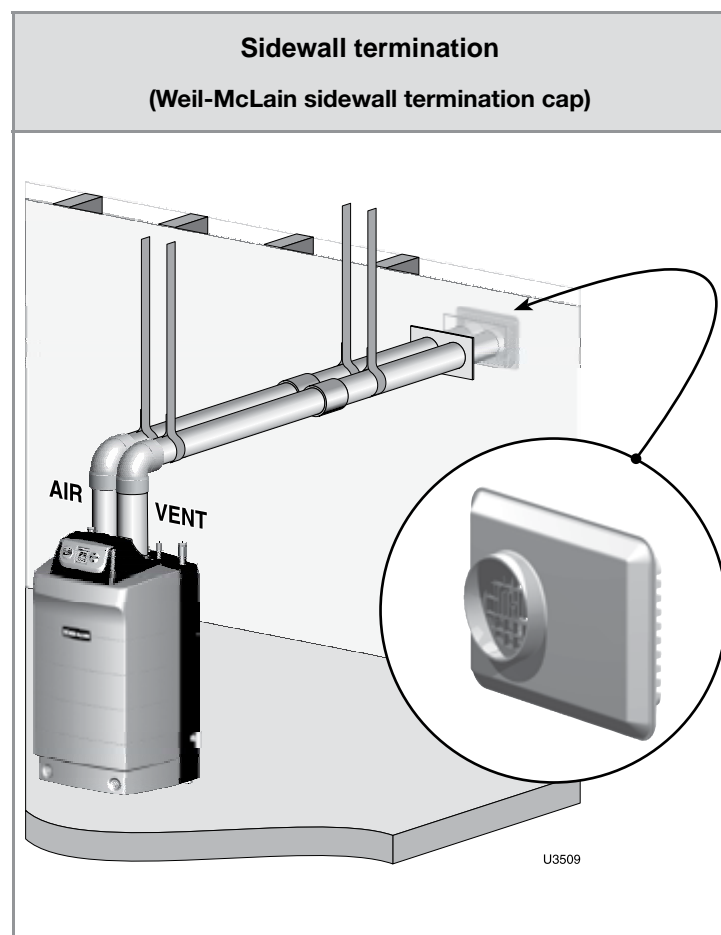

ADVANCED INSTALLATION

Commonwealth of Massachusetts

When the boiler is installed within the Commonwealth of Massachusetts:

- This product must be installed by a licensed plumber or gas fitter.
- Sidewall vent air installations — see instructions on page 65.



Sidewall vent/air termination: *Weil-McLain cap* (cont.)

▲WARNING Provide pipe adapters as needed where pipe size is different from termination connections or boiler connections, and for all AL29-4C vent pipe connections at the boiler and the termination.

Allowable vent/air pipe materials

1. Use only the materials listed in Figure 13, page 19.

Maximum piping length

1. Locate the termination such that the total air piping and vent piping from the boiler to the termination will not exceed the maximum length given in Figure 69.
2. Maximum lengths listed in Figure 69 allow for 2 elbows. Additional elbows required a reduction in maximum length as explained in the table notes.

Figure 69 Maximum piping lengths for Weil-McLain sidewall vent/air plate

Boiler Ultra	Maximum Piping, 2" *		Maximum Piping, 3" *		Maximum Piping, 4" *	
	Feet	Elbows	Feet	Elbows	Feet	Elbows
-80 **	100	2	100	2	Not allowed	
-105 **	100	2	100	2		
-155	Not allowed		100	2		
-230	Not allowed		30	2	100	2
-299	Not allowed		Not allowed		100	2
-399	Not allowed		Not allowed		100	2

* Install pipe reducers to adapt from pipe size used to the 3.5 inch outside diameter required at the termination. You do not have to reduce allowable pipe length for the reducers. Also install reducers as necessary where connecting to the boiler vent and air connections.

** Ultra-80 and 105 boilers installed with 2-inch vent piping automatically derate due to the pressure loss in the vent and air piping. The derate ranges up to 10% for the Ultra-80 at 100 feet or 15% for the Ultra-105 at 100 feet.

For piping using more than 2 elbows, reduce maximum allowable length:

- 7 feet for each additional 4-inch elbow (90° or 45°)
- 7 feet for each additional 2 or 3-inch long radius elbow
- 16 feet for each 2 or 3-inch short radius elbow
- 7 feet for each 2 or 3-inch 45-degree elbow.

Connecting from termination to boiler

1. Install the termination as instructed in the following. Then proceed to page 71 to complete the air and vent piping between the termination and the boiler.

Determine location for termination cap

▲WARNING A gas vent extending through an exterior wall shall not terminate adjacent to the wall or below building extensions such as eaves, parapets, balconies or decks. Failure to comply could result in severe personal injury, death or substantial property damage.

1. Locate the vent/air terminations using the following guidelines.
2. You must consider the surroundings when terminating the vent and air:
 - a. Position the vent termination where vapors will not damage nearby shrubs, plants or air conditioning equipment or be objectionable.
 - b. The flue products will form a noticeable plume as they condense in cold air. Avoid areas where the plume could obstruct window views.
 - c. Prevailing winds could cause freezing of condensate and water/ice buildup where flue products impinge on building surfaces or plants.

Figure 70 Termination location – Weil-McLain vent/air plate – height above grade or snow line

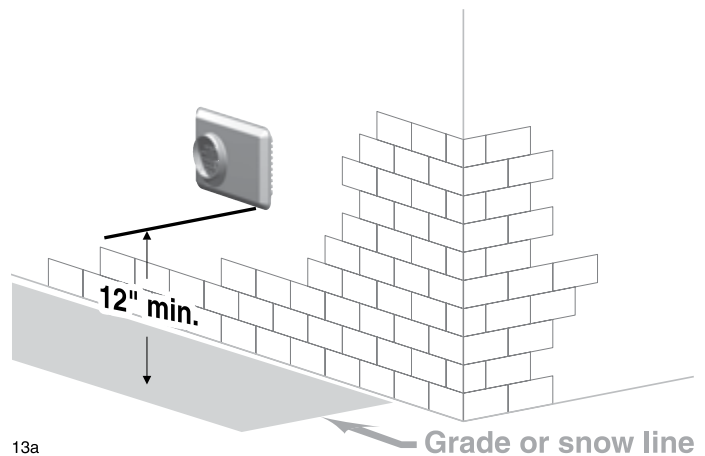

Sidewall vent/air termination: *Weil-McLain cap* (cont.)

- d. Avoid possibility of accidental contact of flue products with people or pets.
 - e. Do not locate the terminations where wind eddies could affect performance or cause recirculation, such as inside building corners, near adjacent buildings or surfaces, window wells, stairwells, alcoves, courtyards or other recessed areas.
 - f. Do not terminate above any door or window or under a deck. Condensate can freeze, causing ice formations.
 - g. Locate or guard vent to prevent condensate damage to exterior finishes.
3. Maintain clearances as shown in Figure 70, page 68, Figure 71, Figure 71 and Figure 73. Also maintain the following:
 - a. Vent must terminate:
 - At least 6 feet from adjacent walls.
 - No closer than 5 feet below roof overhang.
 - At least 7 feet above any public walkway.
 - At least 3 feet above any forced air intake within 10 feet.
 - No closer than 12 inches below or horizontally from any door or window or any other gravity air inlet.
 - b. Air inlet must terminate at least 12" above grade or snow line
 - c. Do not terminate closer than 4 feet horizontally (above or below) from any electric meter, gas meter, regulator, relief valve or other equipment.
 4. Locate terminations so they are not likely to be damaged by foreign objects, such as stones or balls, or subject to buildup of leaves or sediment.

Multiple vent/air terminations

1. When terminating multiple Ultra boilers, terminate each vent/air connection as described in this manual.

WARNING All vent pipes and air inlets must terminate at the same height to avoid possibility of severe personal injury, death or substantial property damage.

2. Place wall penetrations to obtain minimum clearance as shown in Figure 73 for U. S. installations. For Canadian installations, provide clearances required by Natural Gas and Propane Installation CAN/CSA B149.1 or B149.2 Installation Code.
3. The air inlet of an Ultra boiler is part of a direct vent connection. It is not classified as a forced air intake with regard to spacing from adjacent boiler vents.
4. Combustion air (NOT vent piping) can be manifolded as shown in Figure 59, page 59.

Figure 71 Termination location – Weil-McLain vent/air plate – clearances to openings

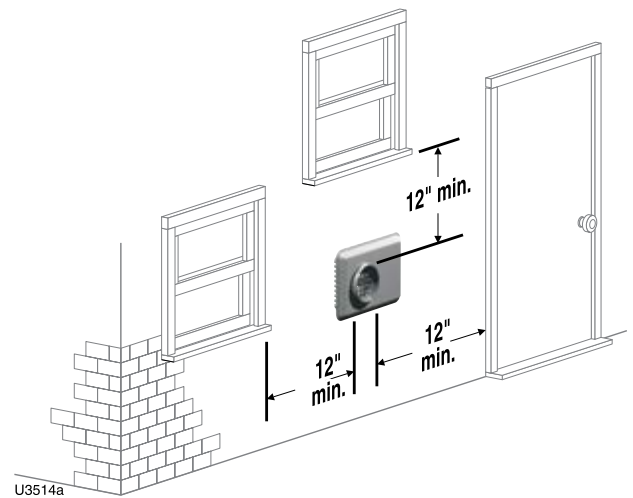

Figure 72 Termination location – Weil-McLain vent/air plate – clearances to public walkway or forced air intake

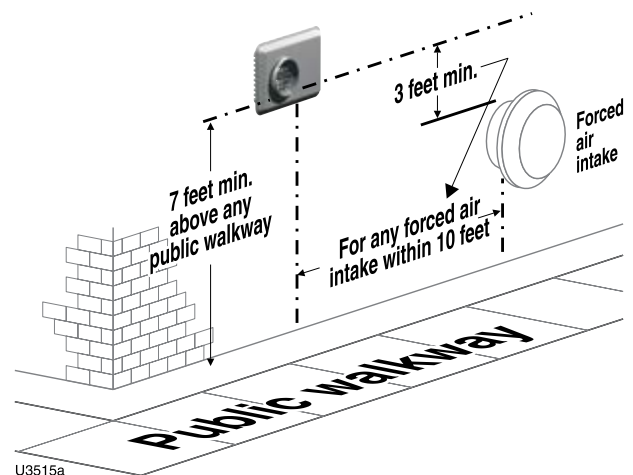
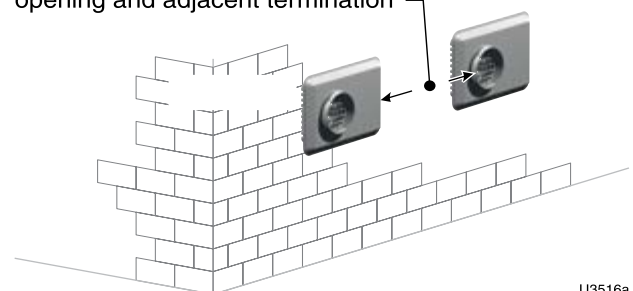

Figure 73 Termination location – Weil-McLain vent/air plate – multiple boilers – clearance from vent to air intake of the next boiler

12" minimum between edge of vent opening and adjacent termination



Sidewall vent/air termination: Weil-McLain cap (cont.)

Install terminations — Weil-McLain vent/air cap

NOTICE The inside and outside cover plates are stamped to identify the exhaust (vent) and intake (air) openings. Make sure to orient the plates correctly.

1. Locate termination opening and avoid obstructions:
 - a. Use the template supplied with the termination kit.
 - b. Locate the template on the outside building surface where the penetration is to be made.
 - c. Make sure there will be no obstructions that might prevent proper placement of the termination.
 - d. Use the template to mark the locations for the four mounting holes, flue pipe and air pipe. Level the template with a spirit level.

WARNING For the Weil-McLain plate, the template must be level to ensure the flue and air pipe will be side-to-side, as shown in Figure 74. Failure to comply could result in severe personal injury, death or substantial property damage.

- e. Cut holes in the wall as shown in Figure 75, using the location marks made with the template. For best results, use a small-diameter, long drill bit to drill centering holes for the flue and air pipe openings. Then drill the large openings from both the inside and outside.
 - f. The flue pipe and air pipe may be run through a rectangular cutout (as marked on the template) in lieu of two separate holes if desired.
2. Drill holes for the screws or plastic anchors to secure the outside plate. Install the outside plate and mount the termination on the plate (temporarily).
 - a. Cut the flue pipe so the extension through the wall will cause the vent pipe to fully extend into the termination socket.
 - b. Cut the air pipe so the extension through the wall will butt the air pipe against the stops inside the termination.
 - c. When using 3-inch vent piping with a 4-inch termination (Ultra-230 applications), increase the flue pipe size to 4 inch before the pipe passes through the wall. This is required to obtain a seal between the flue pipe and the termination.
 - d. Temporarily slide the flue and air pipes through the opening(s). Slide the inside wall plate over the two pipes and into position on the inside wall.
 - e. Position the inside plate so the flue pipe and air pipe slope downward slightly toward the boiler (1/4" per foot).
 - f. Mark the four (4) mounting holes for the plate.
 - g. Remove the vent and air pipe, drill the four mounting holes, and mount the inside plate.
 3. Test fit the vent/air termination on the vent pipe. Make sure the vent pipe fully penetrates the termination socket and the air pipe butts against the interior stops.
 4. Apply silicon RTV sealant to the interior of the vent termination and slide onto vent pipe. Rotate slightly to spread the silicon to ensure a tight seal around the vent pipe.
 5. Secure the termination in place using the four (4) #10 x 1/2" sheet metal screws and lock washers (see Figure 75).

Figure 74 Hole preparation in wall — Weil-McLain vent/air plate

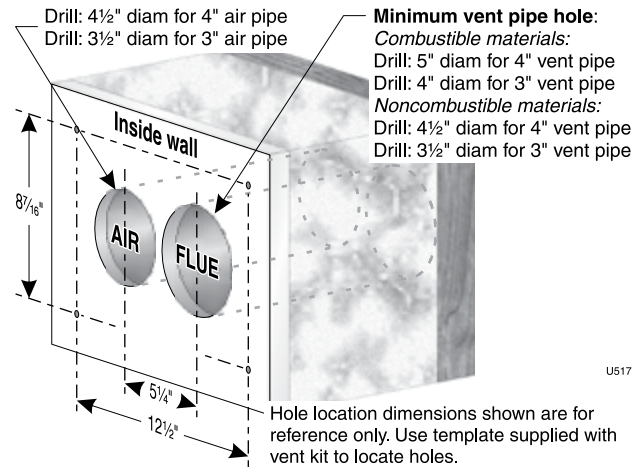

Figure 75 Termination assembly — Weil-McLain vent/air plate

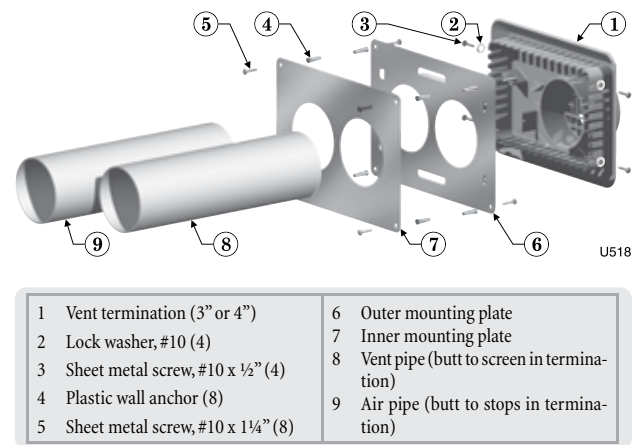
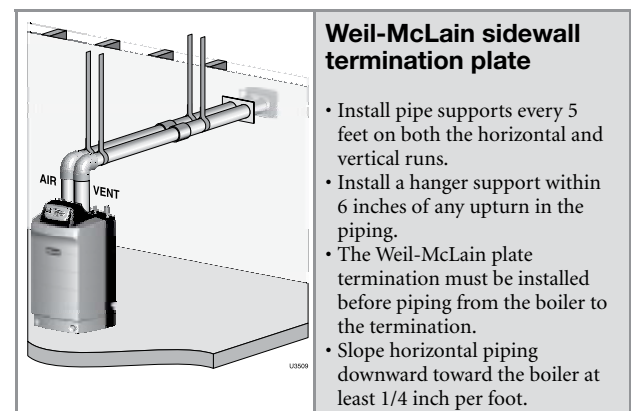

Figure 76 Install termination plate



Install vent/air piping — boiler to W-M termination

Complete termination preparation

1. Install vent and air terminations before proceeding. See previous pages for instructions.

Installing vent and air piping

1. For reference in the following, see previous pages.
2. Work from the boiler to vent or air termination. Do not exceed the lengths given in the previous pages for either the air or vent piping.
 - a. As shown in the maximum length tables, the Ultra-80 or Ultra-105 may be installed with either 2-inch or 3-inch vent and air piping.
 - b. As shown in the maximum length tables, the Ultra-230 may be installed with either 3-inch or 4-inch vent and air piping.
 - c. You must install appropriate pipe reducers, where required, at both the boiler and at the termination assembly.
3. See Figure 77 for attaching vent and air pipes at the boiler.
4. Cut pipe to required lengths.
5. Deburr inside and outside of pipe ends.
6. Chamfer outside of each pipe end to ensure even cement distribution when joining.
7. Clean all pipe ends and fittings. Dry thoroughly.
8. Dry assemble entire vent or air piping to ensure proper fit before assembling any joint.
9. For each joint:
 - a. Handle fittings and pipes carefully to prevent contamination of surfaces.
 - b. Apply primer liberally to both joint surfaces — pipe end and fitting socket.
 - c. While primer is still damp, lightly apply approved cement to both surfaces in a uniform coating.
 - d. Apply a second coat to both surfaces. Avoid using too much cement on sockets to prevent cement buildup inside.
 - e. With cement still wet, insert pipe into fitting, twisting $\frac{1}{4}$ turn. Make sure pipe is fully inserted.
 - f. Wipe excess cement from joint. Check joint to be sure a smooth bead of cement shows around the entire joint.
10. Install pipe supports as shown in Figure 76, page 70.
11. Slope vent and air piping continuously toward boiler, with at least $\frac{1}{4}$ inch drop per foot of run. Do not allow sags at any point.
12. Maintain minimum clearance of $\frac{3}{16}$ inch between vent pipe and any combustible wall or material.
13. Seal wall or floor penetration openings following local code requirements.

Figure 77 Boiler vent and air connections

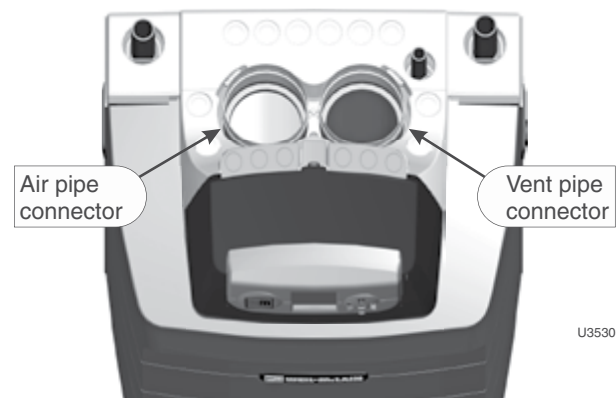

Inserting/securing vent or air pipe into boiler connectors

▲WARNING AL29-4C vent pipe — If using AL29-4C stainless vent pipe, you must install a PVC-to-vent pipe adapter at the boiler vent connection (and at the termination if using the Weil-McLain plate or the concentric termination). Use only the adapter made by the vent pipe manufacturer.

1. PVC/ABS pipe — Clean and chamfer insertion end of pipe. Deburr inside of insertion end. Clean and deburr inside and outside of other end of pipe.

▲WARNING The pipe end must be smooth and chamfered to prevent possible damage to sealing gasket in vent or air pipe adapter. Failure to comply could result in leakage, causing possible severe personal injury or death.

2. Inspect vent or air adapter (above) — verify no obstructions or foreign objects inside.
3. Loosen clamp screw.
4. Measure $3\frac{1}{2}$ inches from end of pipe and make a mark with felt-tip pen.
5. Loosen adapter clamp screw.
6. Apply small amount of silicon grease to end of pipe to ease insertion.
7. Insert pipe into adapter.
8. Slide pipe down until the $3\frac{1}{2}$ -inch mark is reached.

▲WARNING Do not apply excessive force or bend the adapter or flue/air pipe when inserting. The adapter or seal could be damaged.

9. Secure vent or air pipe by tightening the adapter clamp securely. Do not overtighten. The seal is accomplished with the internal gasket. The clamp is only to hold the pipe in place.



Sidewall vent/air termination: 3" or 4" concentric

Termination kit — 3" or 4" concentric termination

1. The 3" or 4" concentric termination kit must be purchased separately. See below.

▲WARNING Use only the vent materials and kits listed in Figure 12, page 18 for concentric venting. Provide pipe adapters as specified in Figure 12, page 18.

Commonwealth of Massachusetts

When the boiler is installed within the Commonwealth of Massachusetts:

- This product must be installed by a licensed plumber or gas fitter.
- See instruction in the Boiler manual.

Allowable vent/air pipe materials

▲WARNING Use only the materials listed in Figure 13, page 19.

Maximum piping length

1. Locate the termination such that the total air piping and vent piping from the boiler to the termination will not exceed the maximum length given in Figure 12, page 18.
2. Maximum lengths listed in Figure 12, page 18 allow for 1 elbow. Additional elbows required a reduction in maximum length as explained in the table notes.

Connecting from termination to boiler

1. Install the termination as instructed in the following.
2. Then proceed to page 82 to complete the air and vent piping between the termination and the boiler.
3. The center lines between the air and vent are wider at the concentric termination connections than at the boiler. See Figure 87, page 77 for suggestions on adjusting the spacing when required. In addition to the method given there, you can rotate the Y-fitting slightly, which will cause the air pipe to be slightly higher or lower than the vent, but the center lines will match those at the boiler vent and air connections.

Determine locations for terminations

▲WARNING A gas vent extending through an exterior wall shall not terminate adjacent to the wall or below building extensions such as eaves, parapets, balconies or decks. Failure to comply could result in severe personal injury, death or substantial property damage.

Locate the vent/air terminations using the following guidelines.

1. You must consider the surroundings when terminating the vent and air:
 - a. Position the vent termination where vapors will not damage nearby shrubs, plants or air conditioning equipment or be objectionable.

Figure 78 Termination location — 3" or 4" concentric termination — height above grade or snow line

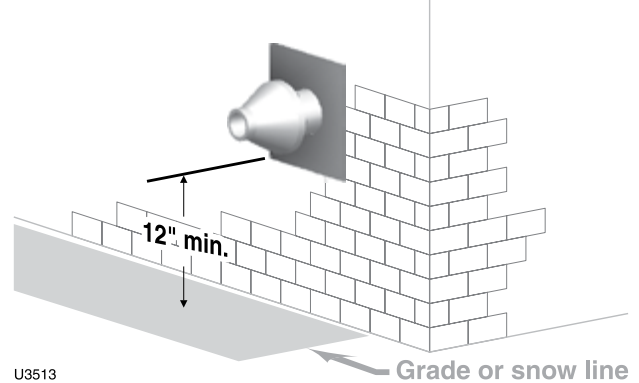
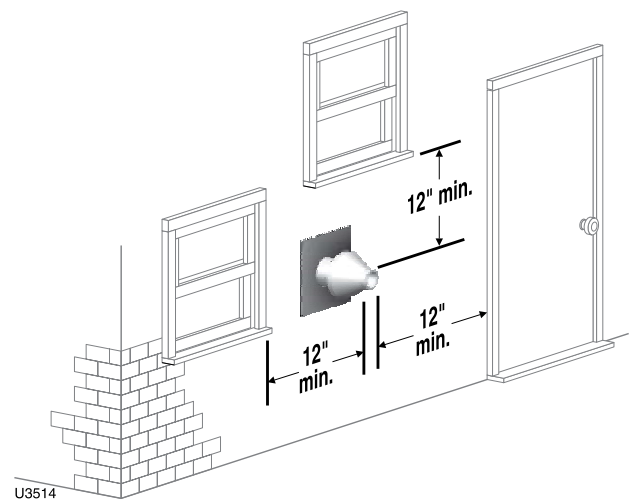

Figure 79 Termination location — 3" or 4" concentric termination — clearances to openings



▲WARNING All vent and air pipes require a **bird screen at each termination**. Most kits do not include the screens. Purchase separately from Weil-McLain or vent kit supplier if not included.

Sidewall vent/air termination: 3" or 4" concentric (cont.)

- b. The flue products will form a noticeable plume as they condense in cold air. Avoid areas where the plume could obstruct window views.
 - c. Prevailing winds could cause freezing of condensate and water/ice buildup where flue products impinge on building surfaces or plants.
 - d. Avoid possibility of accidental contact of flue products with people or pets.
 - e. Do not locate the terminations where wind eddies could affect performance or cause recirculation, such as inside building corners, near adjacent buildings or surfaces, window wells, stairwells, alcoves, courtyards or other recessed areas.
 - f. Do not terminate above any door or window or under a deck. Condensate can freeze, causing ice formations.
 - g. Locate or guard vent to prevent condensate damage to exterior finishes.
2. Maintain clearances as shown in Figure 78, Figure 79, Figure 80 and Figure 81. Also maintain the following:
 - a. Vent must terminate:
 - At least 6 feet from adjacent walls.
 - No closer than 5 feet below roof overhang.
 - At least 7 feet above any public walkway.
 - At least 3 feet above any forced air intake within 10 feet.
 - No closer than 12 inches below or horizontally from any door or window or any other gravity air inlet.
 - b. Air inlet must terminate at least 12" above grade or snow line.
 - c. Do not terminate closer than 4 feet horizontally (above or below) from any electric meter, gas meter, regulator, relief valve or other equipment.
 3. Locate terminations so they are not likely to be damaged by foreign objects, such as stones or balls, or subject to buildup of leaves or sediment.

Multiple vent/air terminations

1. When terminating multiple Ultra boilers, terminate each vent/air connection as described in this addendum.

- ⚠WARNING** All vent pipes and air inlets must terminate at the same height to avoid possibility of severe personal injury, death or substantial property damage.
2. Place wall penetrations to obtain minimum clearance as shown in Figure 81 for U. S. installations. For Canadian installations, provide clearances required by CSA B149.1 or B149.2 Installation Code.
 3. The air inlet of an Ultra boiler is part of a direct vent connection. It is not classified as a forced air intake with regard to spacing from adjacent boiler vents.
 4. Combustion air (NOT vent piping) can be manifolded as shown in Boiler manual, page 55.

Figure 80 Termination location — 3" or 4" concentric termination — clearances to public walkway or forced air intake

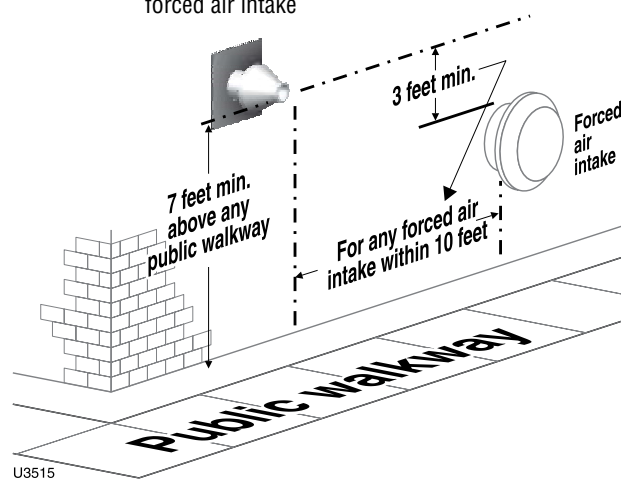
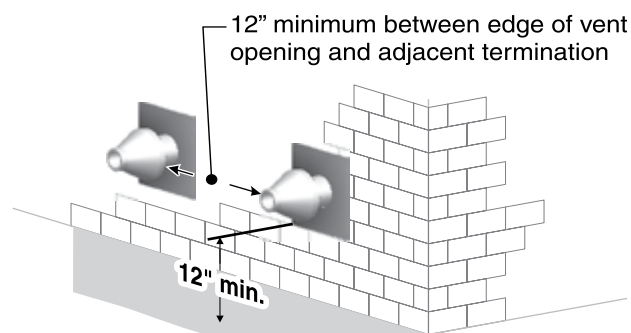

Figure 81 Termination location — 3" or 4" concentric termination — multiple boilers — clearance from vent of one to air intake of the next





Sidewall vent/air termination: 3" or 4" concentric (cont.)

Install terminations — concentric pipes

1. Assemble the vent termination as described for vertical concentric terminations, beginning on page 76.

▲WARNING If necessary, you can shorten the lengths of the inner and outer pipes for a shorter finished assembly. But you must ensure the pipes butt correctly at both ends. Failure to properly assemble the concentric termination can result in flue gas recirculation, causing possible severe personal injury or death.

2. Wall penetration:
 - a. 3" termination: Preferably, use a thimble with a 4½-inch hole. If not using a thimble, carefully use a hole saw to cut a hole not larger than 4¾ inches in diameter through the wall. The finished hole must provide a solid stop for the rain cap ribs, as shown in the inset to Figure 82.
 - b. 4" termination: Preferably, use a thimble with a 6-inch hole. If not using a thimble, carefully use a hole saw to cut a hole not larger than 6¼ inches in diameter through the wall. The finished hole must provide a solid stop for the rain cap ribs, as shown in the inset to Figure 82.
3. Secure the termination in place so the rain cap will butt against the outside wall or outer thimble plate as shown in Figure 82.
4. Before beginning vent and air piping from the boiler to the concentric termination, mount and secure the concentric termination as shown in Figure 82 and Figure 105.

▲WARNING The vent and air piping must be securely supported, and must not rest its weight on the boiler fittings. Failure to properly support the vent and air piping could result in vent piping damage, resulting in possible severe personal injury, death or substantial property damage.

The supports/bracing used must support the termination assembly to prevent slippage or movement.

The clamps used on the outside of the termination pipe must not cut into the pipe or contain sharp edges that could cause a crack to form.

▲WARNING When inserting the partially-assembled termination kit through the roof penetration, wrap plastic or other protection over the end of the exposed assembly to prevent debris from entering the pipes. If the air passages become blocked, the boiler will not operate. Once the rain cap has been cemented to the assembly, there is no way to correct the problem. The assembly would have to be replaced if it were cut to be removed and cleaned. Altering the assembly in any way could result in severe personal injury or death due to toxic flue product emissions.

▲WARNING When using AL29-4C stainless vent pipe, use the vent pipe manufacturer's PVC adapter when connecting to the concentric vent attachment.

5. After the assembly has been positioned in the opening and all supports have been attached, install a bird screen (purchased separately if not included with the kit) and rain cap as follows:
 - a. Place the bird screen on the end of the inner pipe as in Figure 89, page 78.
 - b. Cement the rain cap in place as shown.

Figure 82 Installing and supporting the concentric sidewall vent assembly

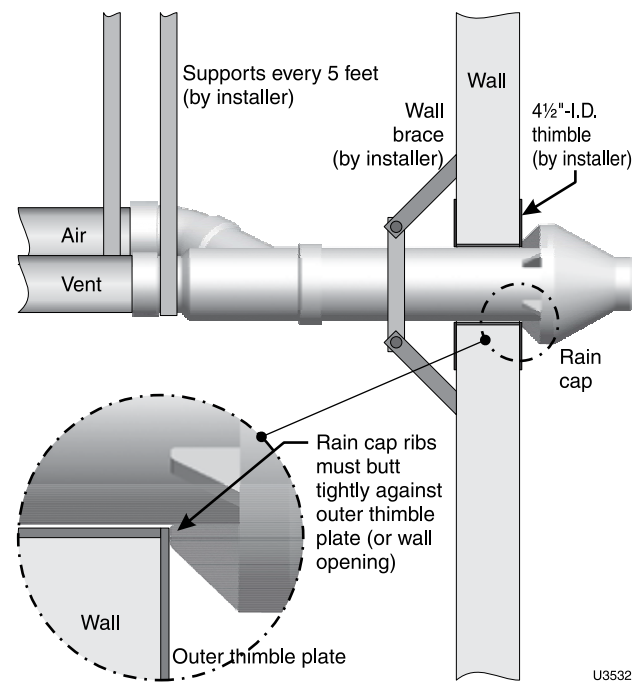

▲WARNING Ensure that the wall material is strong enough to prevent the rain cap from being pushed inward if struck or pushed from the outside.

Figure 83 Concentric termination requirements

	<p>Concentric termination (installing termination — see page 76)</p>
	<p>Install pipe supports every 5 feet on both the horizontal and vertical runs.</p> <ul style="list-style-type: none"> • Install a hanger support within 6 inches of any upturn in the piping. • The concentric termination assembly must be installed before piping from the boiler to the termination. • Support the termination at the wall as shown in the termination instructions. • Slope horizontal piping downward toward the boiler at least 1/4 inch per foot. • Rotate the concentric termination Y-fitting about 30° to result in pipe centers the same as at the boiler.

Vertical vent/air termination: 3" or 4" concentric

Termination kit — 3" or 4" concentric termination

1. The 3" or 4" concentric termination kit must be purchased separately. See below.

▲WARNING Use only the vent materials and kits listed in Figure 12, page 18 for concentric venting. Provide pipe adapters as specified in Figure 12, page 18.

Allowable vent/air pipe materials

▲WARNING Use only the materials listed in Figure 13, page 19.

Maximum piping length

1. Locate the termination such that the total air piping and vent piping from the boiler to the termination will not exceed the maximum length given in Figure 12, page 18.
2. Maximum lengths listed in Figure 12, page 18 allow for 1 elbow. Additional elbows required a reduction in maximum length as explained in the table notes.

Connecting from termination to boiler

1. Install the termination as instructed in the following. Then proceed to page 82 to complete the piping between the termination and the boiler.

Determine location

Locate the concentric vent/air termination using the following guidelines:

1. The concentric vent/air assembly must terminate as shown in Figure 84.
2. The vent and air piping connected to the termination assembly must comply with the instructions in this supplement.
3. You must consider the surroundings when terminating the vent and air:
 - a. Position the termination where vent vapors will not damage nearby shrubs, plants or air conditioning equipment or be objectionable.
 - b. The flue products will form a noticeable plume as they condense in cold air. Avoid areas where the plume could obstruct window views.
 - c. Prevailing winds could cause freezing of condensate and water/ice buildup where flue products impinge on building surfaces or plants.
 - d. Avoid possibility of accidental contact of flue products with people or pets.
 - e. Do not locate the termination where wind eddies could affect performance or cause recirculation, such as inside building corners, near adjacent buildings or surfaces, window wells, stairwells, alcoves, courtyards or other recessed areas.
 - f. Locate or guard vent outlet to prevent condensate damage to exterior finishes.
4. Maintain clearances to termination as given below:
 - a. Vent outlet must be located:

Figure 84 Vertical termination — 3" or 4" concentric

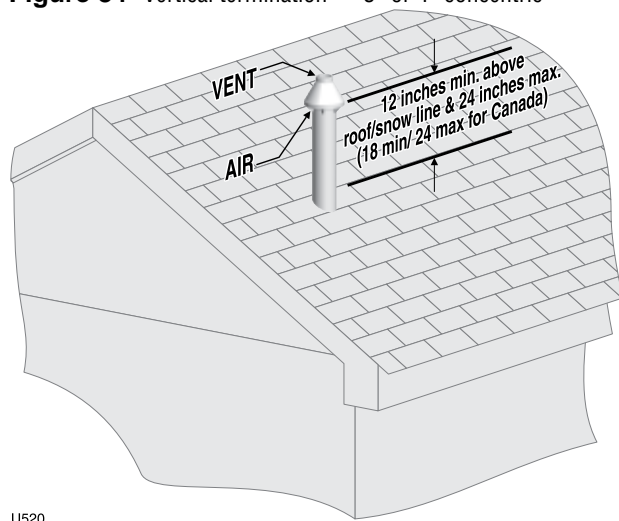
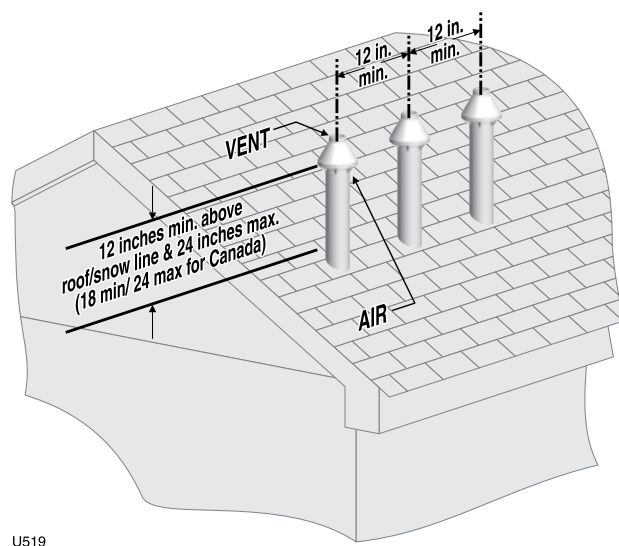

Figure 85 Vertical termination — 3" or 4" concentric — multiple boilers



▲WARNING All vent and air pipes require a **bird screen at each termination**. Most kits do not include the screens. Purchase separately from Weil-McLain or vent kit supplier if not included.



Vertical vent/air termination: 3" or 4" concentric (cont.)

- At least 6 feet from adjacent walls.
 - No closer than 5 feet below roof overhang.
 - At least 7 feet above any public walkway.
 - At least 3 feet above any forced air intake within 10 feet.
 - No closer than 12 inches below or horizontally from any door or window or any other gravity air inlet.
- b. Air inlet must terminate at least 12 inches above the roof or snow line as shown in Figure 84, page 75. (For Canada, the minimum is 18 inches.)
 - c. Do not terminate closer than 4 feet horizontally from any electric meter, gas meter, regulator, relief valve or other equipment. Never terminate above or below any of these within 4 feet horizontally.
5. Locate termination so it is not likely to be damaged by foreign objects, such as stones or balls, or subject to buildup of leaves or sediment.
 6. Do not connect any other appliance to the vent pipe or multiple boilers to a common vent pipe.

Multiple vent/air terminations

1. When terminating multiple Ultra boilers, install the concentric vent/air termination assemblies as described in this addendum.

▲WARNING All vent outlets must terminate at the same height to avoid possibility of severe personal injury, death or substantial property damage.

2. Place roof penetrations to obtain minimum of 12 inches between centers of adjacent vent pipe of another boiler for U. S. installations (see Figure 85, page 75).
3. For Canadian installations, provide clearances required by CSA B149.1 or B149.2 Installation Code.
4. The air inlet of an Ultra boiler is part of a direct vent connection. It is not classified as a forced air intake with regard to spacing from adjacent boiler vents.

Prepare roof penetrations

1. Roof penetration hole:
 - a. 3" termination: Cut a 5-inch diameter hole to clear the 4½-inch termination outside diameter.
 - b. 4" termination: Cut a 6.5-inch diameter hole to clear the 6-inch termination outside diameter.
 - c. Insert a galvanized metal thimble in the vent pipe hole.
2. Follow all local codes for isolation of vent pipe when passing through floors, ceilings and roofs.
3. Provide flashing and sealing boots sized for the concentric termination outside diameter.

Assembling the concentric termination

1. See Figure 89, page 78 for the dimensions and details of the termination assembly.
2. Prepare the bird screen (purchased separately if not included with the kit). Cut the bird screen to size if required. If the bird screen must be trimmed, cut the bird screen to fit the outside diameter of the PVC inner pipe supplied with the termination kit.

3. Partially assemble the vent termination kit in the sequence shown in Figure 89, page 78.

▲WARNING **DO NOT** install the rain cap and bird screen until the assembly has been inserted through the roof and all supports have been installed. Follow instructions to cover the end of the assembly with plastic before inserting through the roof penetration to prevent debris from blocking the air passages.

4. Use the following procedures to prepare termination components and cement together.
5. Deburr inside and outside of pipe ends.
6. Chamfer outside of each pipe end to ensure even cement distribution when joining.
7. Clean all pipe ends and fittings.
8. Dry thoroughly.
9. Dry assemble entire vent or air piping to ensure proper fit before assembling any joint.
10. For each joint:
 - a. Handle fittings and pipes carefully to prevent contamination of surfaces.
 - b. Apply primer liberally to both joint surfaces — pipe end and fitting socket.
 - c. While primer is still damp, lightly apply approved cement to both surfaces in a uniform coating.
 - d. Apply a second coat to both surfaces. Avoid using too much cement on sockets to prevent cement buildup inside.
 - e. With cement still wet, insert pipe into fitting, twisting ¼ turn. Make sure pipe is fully inserted.

▲WARNING If necessary, you can shorten the lengths of the inner and outer pipes for a shorter finished assembly. But you must ensure the pipes butt correctly at both ends. Failure to properly assemble the concentric termination can result in flue gas recirculation, causing possible severe personal injury or death.

Mount concentric termination

1. Before beginning vent and air piping from boiler, mount and secure the concentric termination as shown in Figure 106, page 92, and Figure 88, page 77.

▲WARNING The vent and air piping must be securely supported, and must not rest its weight on the boiler fittings. **DO NOT** drill or screw into either the vent pipe or air pipe. Failure to properly support the vent and air piping could result in vent piping damage, resulting in possible severe personal injury, death or substantial property damage.



Vertical vent/air termination: 3" or 4" concentric (cont.)

⚠WARNING When inserting the partially-assembled termination kit through the roof penetration, wrap plastic or other protection over the end of the exposed assembly to prevent debris from entering the pipes. If the air passages become blocked, the boiler will not operate. Once the rain cap has been cemented to the assembly, there is no way to correct the problem. The assembly would have to be replaced if it were cut to be removed and cleaned. Altering the assembly in any way could result in severe personal injury or death due to toxic flue product emissions.

⚠WARNING When using AL29-4C stainless vent pipe, use the vent pipe manufacturer's PVC adapter when connecting to the concentric vent attachment.

1. After the assembly has been positioned in the roof opening and all supports have been attached, install a bird screen (purchased separately if not included with the kit) and rain cap as follows:
 - a. Place the bird screen on the end of the inner pipe as in Figure 89, page 78.
 - b. Cement the rain cap in place as shown.

Vent termination support

1. Support the concentric vent/air termination at the roof penetration as shown in Figure 88.
 - The supports/bracing used must support the termination assembly to prevent vertical slippage or sideways movement.
 - The clamps used on the outside of the termination pipe must not cut into the pipe or contain sharp edges that could cause a crack to form.

Figure 86 Concentric termination requirements

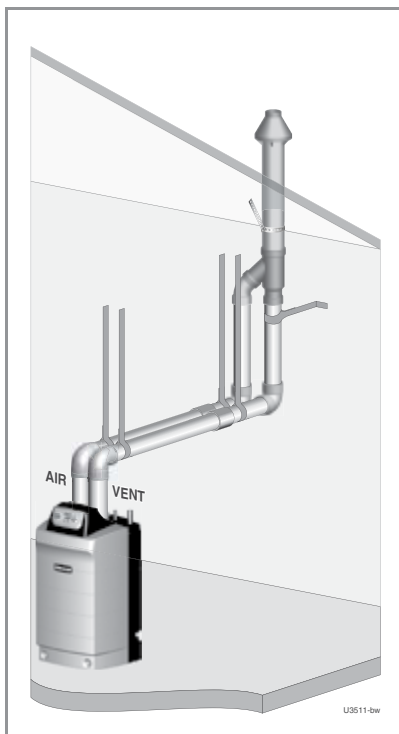

Concentric termination
(installing termination — see page 75)

- Install pipe supports every 5 feet on both the horizontal and vertical runs.
- Install a hanger support within 6 inches of any upturn in the piping.
- **The concentric termination assembly must be installed before piping from the boiler to the termination.**
- Support the termination at the ceiling and above the roof as shown in the termination instructions.
- Slope horizontal piping downward toward the boiler at least 1/4 inch per foot.
- Use long-radius elbows for air piping when using 2" or 3" pipe to reduce pressure drop.
- Rotate the concentric termination Y-fitting about 30° to result in pipe centers the same as at the boiler.

Figure 87 3" or 4" concentric termination supports

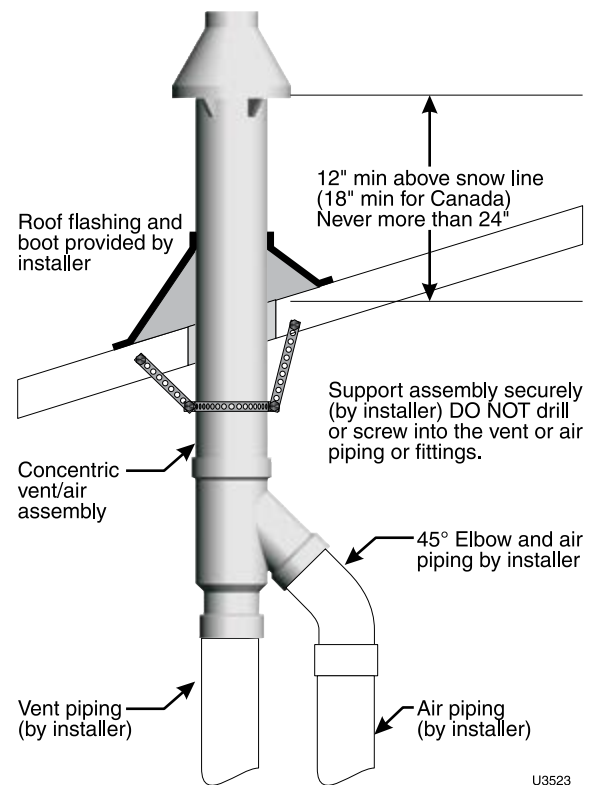
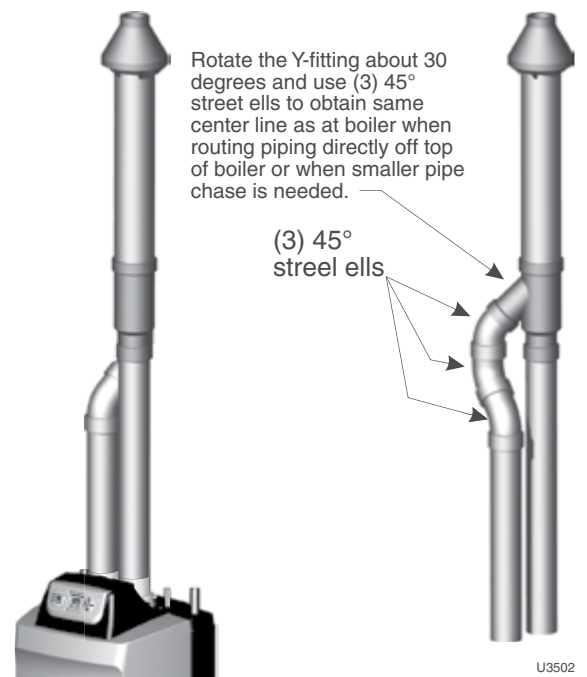

Figure 88 Alternate piping configuration, using (3) 45-degree elbows to obtain closer pipe centers



Concentric vent/air termination assembly

Figure 89 3" or 4" concentric termination assembly — DO NOT attach the rain cap until the termination has been inserted through the roof or wall and all supports have been installed.

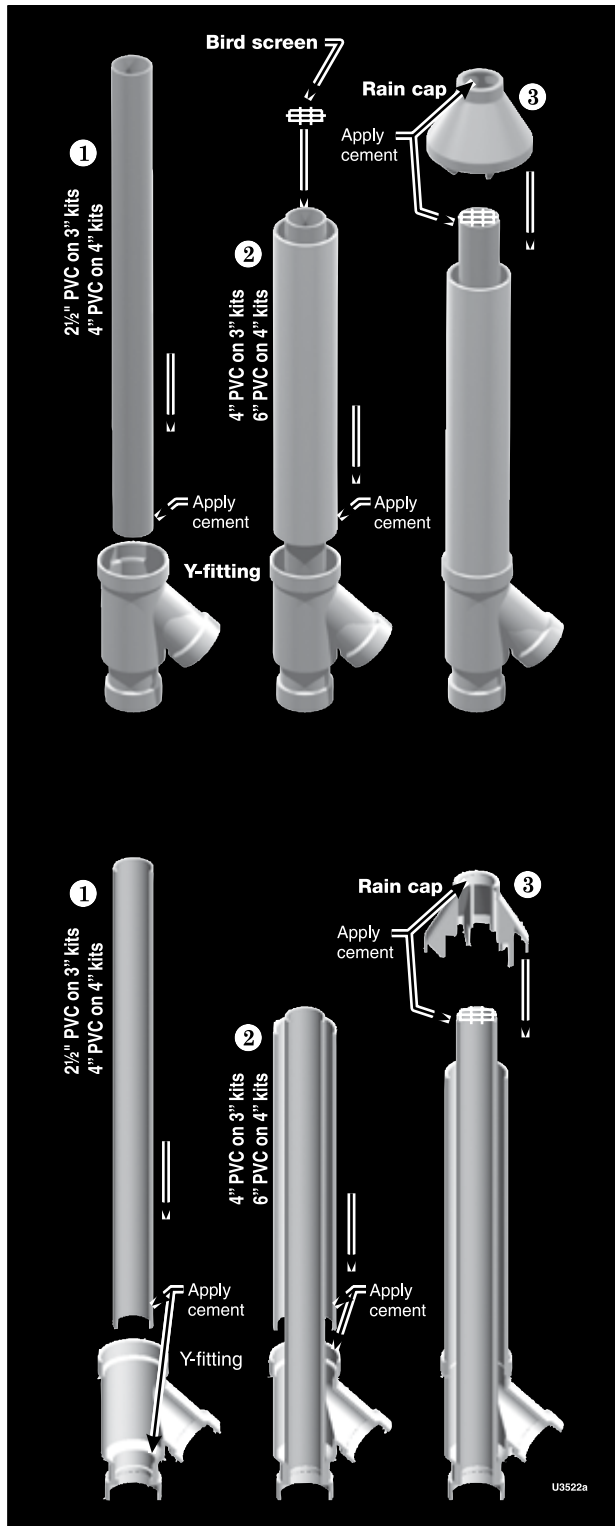
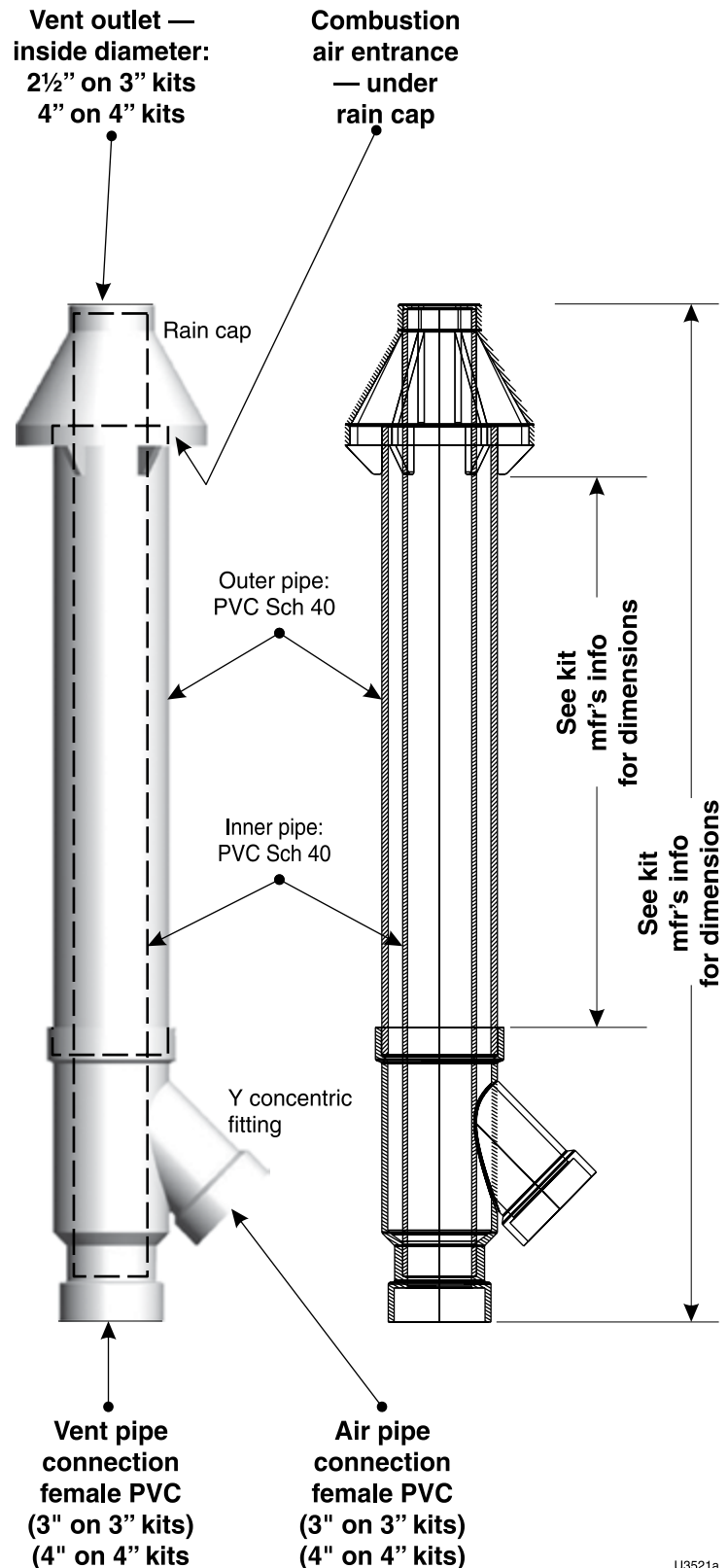

Figure 90 3" or 4" concentric termination assembly (see kit manufacturer's instructions for details)



DIRECT VENT: Vertical vent / sidewall air

Allowable vent/air pipe materials

1. Use only the materials listed in Figure 13, page 19.
2. Purchase bird screens for vent and air terminations separately. See the parts list at the end of this manual.

Maximum piping lengths

1. Locate the terminations such that the total air piping and vent piping from the boiler to the termination will not exceed the maximum length given in Figure 12, page 18.
2. Maximum lengths listed in Figure 12, page 18 allow for 1 elbow in the air piping and 1 elbow in the vent piping. Additional elbows required a reduction in maximum length as explained in the table notes.

Figure 91 Direct vent: Vertical vent / sidewall air

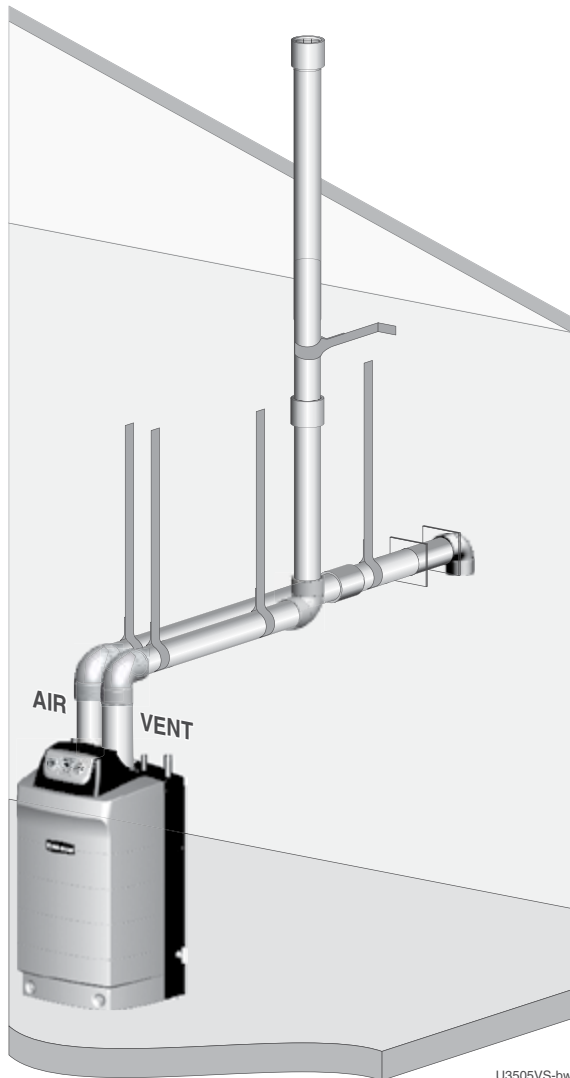

Determine location

1. Locate the vent termination using the following guidelines:
 2. The vent piping must terminate in an up-turned coupling as shown in Figure 92, page 80. The top of the coupling must be at least 1 foot above the air intake.
 3. You must consider the surroundings when terminating the vent and air:
 - a. Position the vent termination where vapors will not damage nearby shrubs, plants or air conditioning equipment or be objectionable.
 - b. The flue products will form a noticeable plume as they condense in cold air. Avoid areas where the plume could obstruct window views.
 - c. Prevailing winds could cause freezing of condensate and water/ice buildup where flue products impinge on building surfaces or plants.
 - d. Avoid possibility of accidental contact of flue products with people or pets.
 - e. Do not locate the terminations where wind eddies could affect performance or cause recirculation into building or appliance air intakes, such as inside building corners, near adjacent buildings or surfaces, window wells, stairwells, alcoves, courtyards or other recessed areas.
 - f. Do not terminate above any door or window. Condensate can freeze, causing ice formations.
 - g. Locate or guard vent to prevent condensate damage to exterior finishes.
4. Maintain clearances to vent termination as given below:
 - a. Vent must terminate:
 - At least 6 feet from adjacent walls.
 - No closer than 5 feet below roof overhang.
 - At least 3 feet above any forced air intake within 10 feet.
 - No closer than 12 inches below or horizontally from any door or window or any other gravity air inlet.
 - b. Do not terminate vent closer than 4 feet horizontally from any electric meter, gas meter, regulator, relief valve or other equipment. Never terminate above or below any of these within 4 feet horizontally.
5. Locate terminations so they are not likely to be damaged by foreign objects, such as stones or balls, or subject to buildup of leaves or sediment.
6. Do not connect any other appliance to the vent pipe. Do not connect multiple boilers to a common vent pipe.

Prepare roof penetrations

1. Vent pipe penetration:
 - a. Cut a hole for the vent pipe. For either combustible or noncombustible construction, size the vent pipe hole at least 0.4" larger than the vent pipe diameter:
 - 2¾" hole for 2"
 - 4" hole for 3"
 - 5" hole for 4"
 - b. Insert a galvanized metal thimble in the vent pipe hole.
2. Follow all local codes for isolation of vent pipe when passing through floors, ceilings and roofs.
3. Provide flashing and sealing boots sized for the vent pipe and air pipe.

DIRECT VENT: Vertical vent / sidewall air *(continued)*

Termination and fittings

1. Prepare the vent termination coupling by inserting a bird screen. Bird screens must be purchased separately. See the parts list at the end of this manual for part numbers.
 - a. If using 3-inch piping for an Ultra-230, cut a 4-inch bird screen by placing 3-inch fitting on screen and cutting around it as a template.
2. Maintain the required dimensions of the finished termination piping as shown in Figure 92.

Multiple vent terminations

1. When terminating multiple Ultra boilers, terminate each vent/air connection as described in this section.
2. Place adjacent terminations at least 6 inches apart.
3. For Canadian installations, provide clearances required by CSA B149.1 or B149.2 Installation Code.

Connecting from vent termination to boiler

1. Install the termination penetration as instructed in the preceding. Then proceed to page 82 to complete the piping between the termination and the boiler.

Determine location for air inlet elbow

1. The air inlet of an Ultra boiler is part of a direct vent connection. It is not classified as a forced air intake with regard to spacing from adjacent appliance terminations.
2. Locate the air inlet elbow (termination) using the following guidelines.
3. The air piping must terminate in a down-turned elbow as shown in Figure 93.
 - a. Apply the configuration on the left side of Figure 93 unless the terminations would fail to meet minimum clearance to grade or snow line.
 - b. Apply the configuration on the right side of Figure 93 when the terminations need to be raised higher to meet clearance to grade or snow line.
 - c. The air pipe may run up the side of the building, as shown. The vent and air pipes must be secured with braces, and all clearances and lengths must be maintained. Space braces no further than 24 inches apart.
4. You must consider the surroundings when terminating the air connection:
 - a. Make sure there are no obstructions for air flow. DO NOT locate the termination where plants could grow and cause obstruction to air flow.
 - b. Do not locate the terminations where wind eddies could affect performance or cause recirculation with exhaust from other appliances, such as inside building corners, near adjacent buildings or surfaces, window wells, stairwells, alcoves, courtyards or other recessed areas.
 - c. Locate the air inlet termination at least 12 inches below and 12 inches horizontally from any appliance or building vent outlet.
5. Locate terminations so they are not likely to be damaged by foreign objects, such as stones or balls, or subject to buildup of leaves or sediment.

Figure 92 Vent termination (through the roof) for direct vent: vertical vent / sidewall air

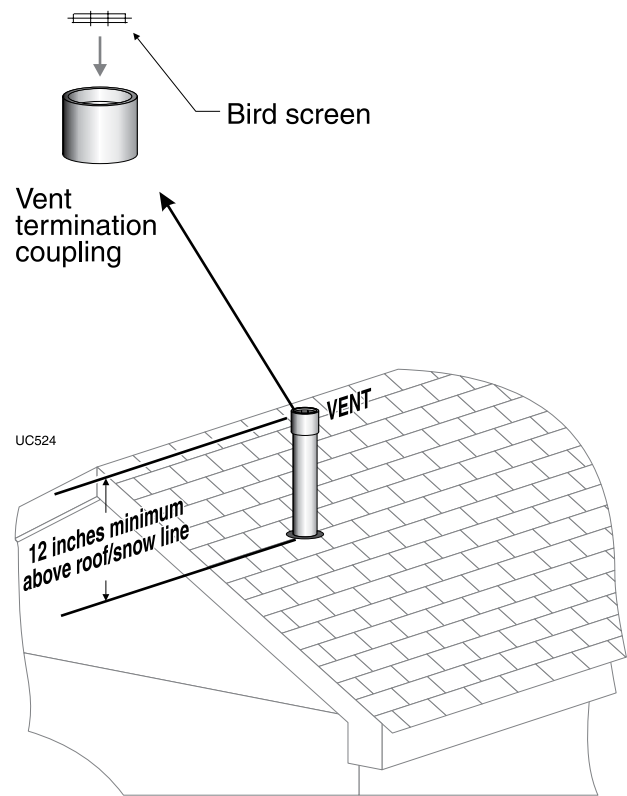
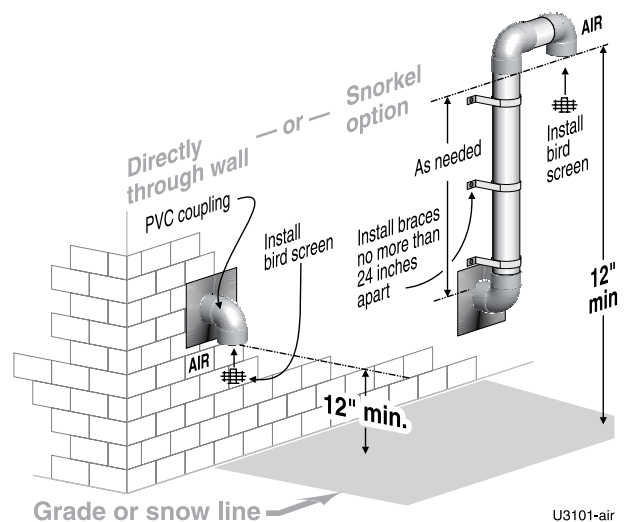

Figure 93 Sidewall air inlet (termination) for direct vent: vertical vent / sidewall air





DIRECT VENT: Vertical vent / sidewall air *(continued)*

Multiple air terminations

1. When terminating multiple Ultra boiler air connections, terminate each air connection as described in this manual.
2. Place wall penetrations to obtain minimum clearances as instructed in this manual.
3. Place adjacent air inlets for multiple Ultra boilers at least 6 inches apart.
4. For Canadian installations, provide clearances required by CSA B149.1 or B149.2 Installation Code.
5. Combustion air (NOT vent piping) can be manifolded as shown in the Ultra boiler manual.

Prepare wall penetrations

1. Air pipe penetration:
 - a. Cut a hole for the air pipe. Size the air pipe hole as close as desired to the air pipe outside diameter.
2. Seal exterior openings thoroughly with exterior caulk.

Termination and fittings

1. Prepare the air termination elbow (Figure 93) by inserting a bird screen. Bird screens must be purchased separately. See the parts list at the end of this manual for part numbers.
2. Use metal plates (by installer) at inside and outside penetrations as shown in Figure 94.

NOTICE If extending the air pipe out from the wall, install a coupling on each pipe. Mount the piping with the coupling flush with the outer plate.

Connecting from air termination to boiler

1. Install the terminations as instructed in the following. Then proceed to page 82 to complete the air and vent piping between the termination and the boiler.

Figure 94 Sidewall air inlet installation for direct vent: vertical vent / sidewall air

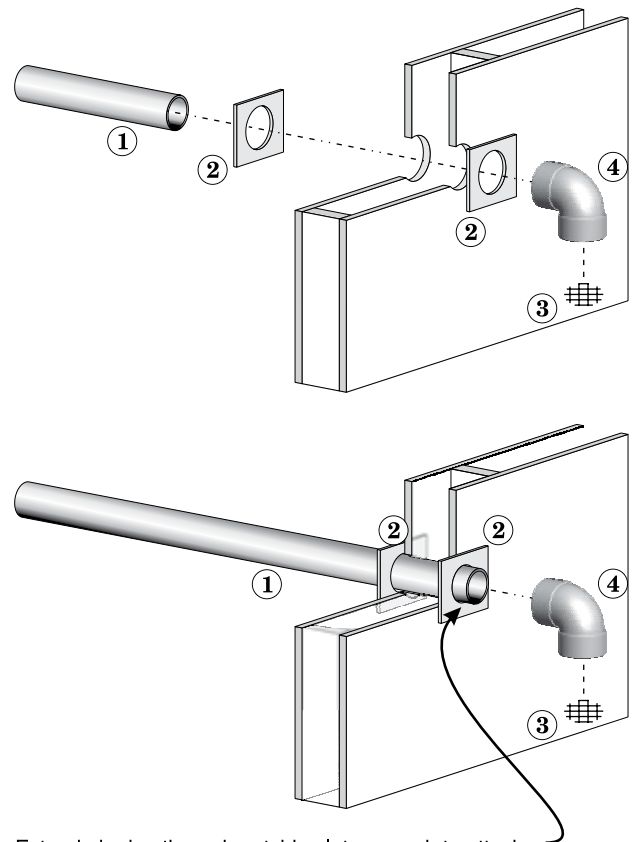

Extend air pipe through outside plate enough to attach termination coupling (or elbow when snorkeled).

U106-air

1 Air piping	3 Bird screen (air), by installer
2 Sidewall plates, by installer	4 Air inlet elbow

Install vent/air piping — boiler to termination

Complete termination preparation

1. Install vent and air terminations before proceeding. See previous pages for instructions.

Installing vent and air piping

1. For reference in the following see:
 - a. Sidewall terminations: see Figure 105, page 92.
 - b. Vertical terminations: see Figure 106, page 92.
2. Work from the boiler to vent or air termination. Do not exceed the lengths given in the previous pages for either the air or vent piping.
 - a. As shown in the maximum length tables, the Ultra-80 or Ultra-105 may be installed with either 2-inch or 3-inch vent and air piping.
 - b. As shown in the maximum length tables, the Ultra-230 may be installed with either 3-inch or 4-inch vent and air piping.
 - c. You must install appropriate pipe reducers, where required, at both the boiler and at the termination assembly.
3. See Figure 95 for attaching vent and air pipes at the boiler.
4. Cut pipe to required lengths.
5. Deburr inside and outside of pipe ends.
6. Chamfer outside of each pipe end to ensure even cement distribution when joining.
7. Clean all pipe ends and fittings. Dry thoroughly.
8. Dry assemble entire vent or air piping to ensure proper fit before assembling any joint.
9. For each joint:
 - a. Handle fittings and pipes carefully to prevent contamination of surfaces.
 - b. Apply primer liberally to both joint surfaces — pipe end and fitting socket.
 - c. While primer is still damp, lightly apply approved cement to both surfaces in a uniform coating.
 - d. Apply a second coat to both surfaces. Avoid using too much cement on sockets to prevent cement buildup inside.
 - e. With cement still wet, insert pipe into fitting, twisting $\frac{1}{4}$ turn. Make sure pipe is fully inserted.
 - f. Wipe excess cement from joint. Check joint to be sure a smooth bead of cement shows around the entire joint.
10. Install pipe supports as shown in Figure 105, page 92 or Figure 106, page 92.
11. Slope vent and air piping continuously toward boiler, with at least $\frac{1}{4}$ inch drop per foot of run. Do not allow sags at any point.
12. Maintain minimum clearance of $\frac{3}{16}$ inch between vent pipe and any combustible wall or material.
13. Seal wall or floor penetration openings following local code requirements.

Figure 95 Boiler vent and air connections

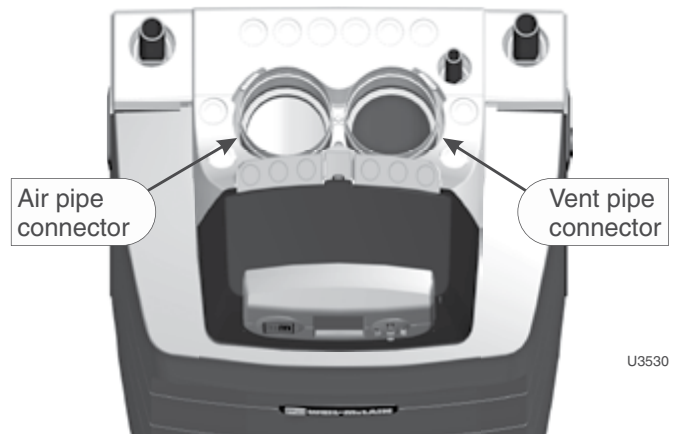

Inserting/securing vent or air pipe into boiler connectors

▲WARNING AL29-4C vent pipe — If using AL29-4C stainless vent pipe, you must install a PVC-to-vent pipe adapter at the boiler vent connection (and at the termination if using the Weil-McLain plate or the concentric termination). Use only the adapter made by the vent pipe manufacturer.

1. PVC/ABS pipe — Clean and chamfer insertion end of pipe. Deburr inside of insertion end. Clean and deburr inside and outside of other end of pipe.

▲WARNING The pipe end must be smooth and chamfered to prevent possible damage to sealing gasket in vent or air pipe adapter. Failure to comply could result in leakage, causing possible severe personal injury or death.

2. Inspect vent or air adapter (above) — verify no obstructions or foreign objects inside.
3. Loosen clamp screw.
4. Measure $3\frac{1}{2}$ inches from end of pipe and make a mark with felt-tip pen.
5. Loosen adapter clamp screw.
6. Apply small amount of silicon grease to end of pipe to ease insertion.
7. Insert pipe into adapter.
8. Slide pipe down until the $3\frac{1}{2}$ -inch mark is reached.

▲WARNING Do not apply excessive force or bend the adapter or flue/air pipe when inserting. The adapter or seal could be damaged.

9. Secure vent or air pipe by tightening the adapter clamp securely. Do not overtighten. The seal is accomplished with the internal gasket. The clamp is only to hold the pipe in place.

DIRECT EXHAUST venting — general

Vent and air piping materials

1. See Figure 13, page 19 for approved vent and air piping materials, for both **direct exhaust** and **direct vent**.

⚠WARNING Use the same vent or air piping material throughout. — Do not connect different types of piping together.

Vent piping

1. Boiler flue gases must be piped from the boiler to outside, following the instructions in this manual, and compliant with all applicable codes. The vent pipe must terminate either through the sidewall or through the roof, located with the correct separation from the air termination. See the associated instructions in the following pages.
2. Each Ultra boiler requires a separate vent. **DO NOT** common vent.

Combustion air openings for direct exhaust

⚠WARNING Provide combustion air openings to boiler room and building. Combustion and ventilation air for direct exhaust boilers is provided from the boiler room. Follow all instructions in the Boiler manual and this addendum plus all applicable codes, providing combustion air openings as specified. Failure to comply could result in severe personal injury, death or substantial property damage.

1. Combustion air must be supplied through openings into the boiler room, following the instructions in this manual, and compliant with all applicable codes. Read the warning on page 16, and ensure the air and boiler room will not contain contaminated air.
2. Where the Ultra boiler shares a space with other appliances, the combustion air openings must be sized to handle the combined requirements of all appliances in the space.

SIDEWALL direct exhaust option

1. Read and follow instructions in Boiler manual, including page 65 for Massachusetts installations when applicable.

VERTICAL direct exhaust option

1. Read and follow instructions in Boiler manual, including page 65 for Massachusetts installations when applicable.

⚠WARNING Every vent pipe requires a **bird screen at its termination**. Bird screens are not supplied with the Ultra boiler. Purchase separately from Weil-McLain.

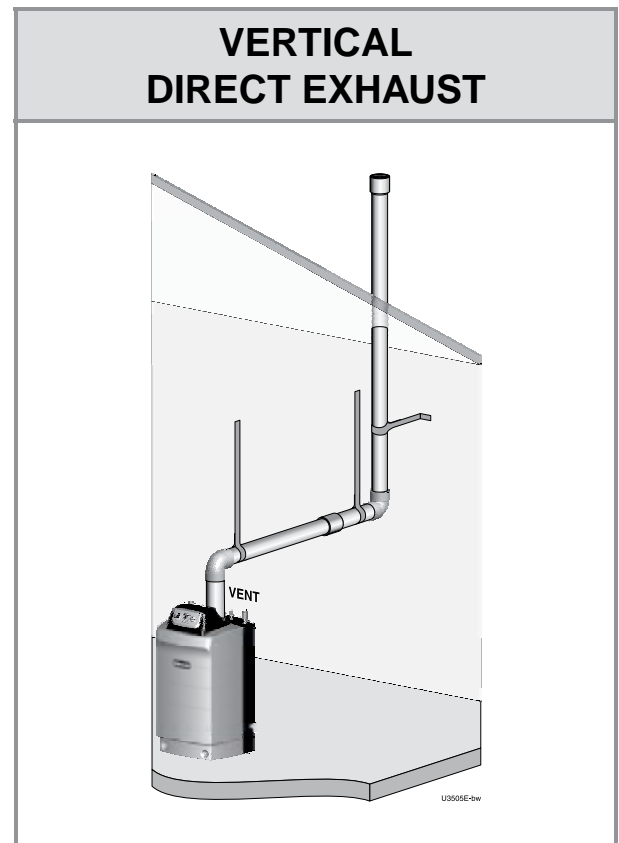
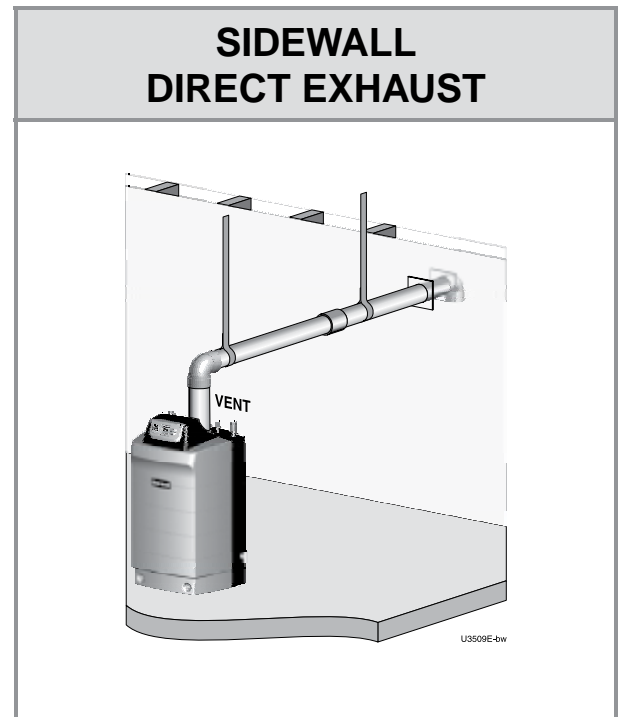

DIRECT EXHAUST — Boiler room air openings

Combustion air provision

The Ultra boiler can use inside air if no contaminants are present in the boiler space. (If contaminants are likely to be present, install the boiler as a direct vent appliance, using the appropriate vent instructions in this manual.)

The boiler room must be fitted with combustion air openings large enough to provide air for all appliances in the room. Use the following information to size the openings. Ensure the installation complies with all applicable codes and standards.

Sizing combustion air openings

Air openings provide for ventilation (as well as combustion air) to prevent overheating of the boiler controls and boiler space. Air is also needed for other appliances located in the same space.

Use Figure 96, page 85, selecting the appropriate installation conditions.

▲WARNING Air openings must be sized to handle all appliances and air movers (exhaust fans, etc.) using the air supply.

The sizing given in Figure 96, page 85 is based on the National Fuel Gas Code, ANSI Z223.1, allowing adequate air openings for gravity-vented gas appliances (Category I) in addition to that needed for the Ultra boiler.

The air openings recommended in Figure 96, page 85 will allow adequate ventilation and combustion air provided the boiler room is not subjected to negative pressure due to exhaust fans or other mechanical ventilation devices.

Refer to the National Fuel Gas Code for dealing with other conditions.

Free area — louver allowance

The free area of openings means the area after reduction for any installed louvers or grilles. Be sure to consider this reduction when sizing the air openings.

Special considerations

Tight construction

ANSI Z223.1 defines unusually tight construction where:

1. Walls and ceilings exposed to the outside atmosphere have a continuous water vapor retarder with a rating of 1 perm or less with openings gasketed, and . . .
2. Weather-stripping has been added on openable windows and doors, and . . .
3. Caulking or sealants are applied to areas such as joints around windows and door frames, between sole plates and floors, between wall-ceiling joints, between wall panels, at penetrations for plumbing, electrical, and gas lines, and in other openings.

For buildings with such construction, provide air openings into the building from outside, sized per the appropriate case in Figure 96, page 85 if appliances are to use inside air for combustion and ventilation.

Exhaust fans and air movers

The appliance space must never be under a negative pressure unless all appliances are installed as direct vent. Always provide air openings sized not only to the dimensions required for the firing rate of all appliances, but also to handle the air movement rate of the exhaust fans or air movers using air from the building or space.

Motorized air dampers

If the air openings are fitted with motorized dampers, electrically interlock the damper to:

- Prevent the boiler from firing if the damper is not fully open.
- Shut the boiler down should the damper close during boiler operation.

To accomplish this interlock, wire an isolated contact (proving the damper open) in series with the thermostat input to the boiler. The boiler will not start if this contact is open, and will shut down should it open during operation.



DIRECT EXHAUST — Boiler room air openings *(continued)*

Figure 96 MINIMUM combustion air openings for direct exhaust applications — ALL OPENING SIZES ARE FREE AREA

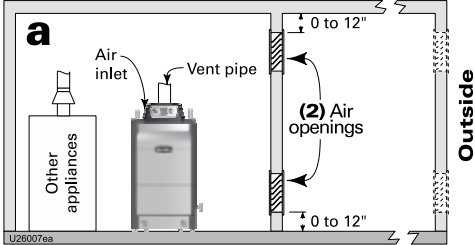
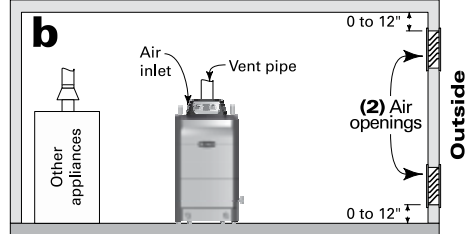
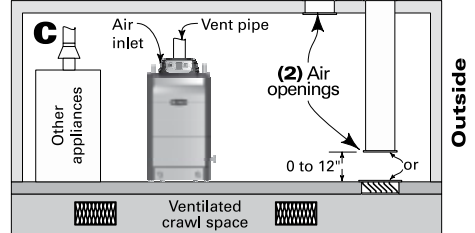
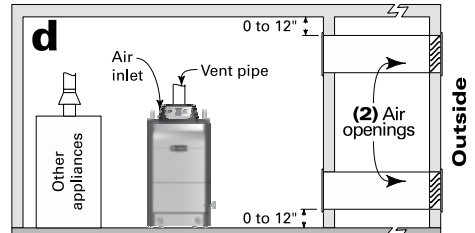
<p style="text-align: center;">Air openings</p> <p>The required air opening sizes below are FREE AREA, after reduction for louver obstruction. Note the exception below for large spaces.</p>	<p style="text-align: center;">Ultra boiler WITH other appliances in room</p>	<p style="text-align: center;">Ultra boiler WITHOUT other appliances in room</p>
 <p>a</p>	<p>TWO openings, each at least: 1 square inch per 1,000 Btuh of all appliances in the room</p>	<p>TWO openings, each at least: 1 square inch per 4,000 Btuh of all appliances in the room</p>
 <p>b</p>	<p>TWO openings, each at least: 1 square inch per 4,000 Btuh of all appliances in the room — OR — ONE opening **, each at least: 1 square inch per 3,000 Btuh of all appliances in the room</p>	<p>TWO openings, each at least: 1 square inch per 4,000 Btuh of all appliances in the room — OR — ONE opening **, each at least: 1 square inch per 3,000 Btuh of all appliances in the room</p>
 <p>c</p> <p style="text-align: center;">Ventilated crawl space</p>	<p>TWO openings, each at least: 1 square inch per 2,000 Btuh of all appliances in the room — OR — ONE opening **, each at least: 1 square inch per 3,000 Btuh of all appliances in the room</p>	<p>TWO openings, each at least: 1 square inch per 4,000 Btuh of all appliances in the room — OR — ONE opening **, each at least: 1 square inch per 3,000 Btuh of all appliances in the room</p>
 <p>d</p>	<p>TWO openings, each at least: 1 square inch per 4,000 Btuh of all appliances in the room — OR — ONE opening **, each at least: 1 square inch per 3,000 Btuh of all appliances in the room</p>	<p>TWO openings, each at least: 1 square inch per 4,000 Btuh of all appliances in the room — OR — ONE opening **, each at least: 1 square inch per 3,000 Btuh of all appliances in the room</p>
<p>** NOTICE: Requirements for using the SINGLE air opening option.</p>	<p>A single combustion air opening can be used for cases b, c or d above, sized as listed, provided that:</p> <ul style="list-style-type: none"> • The single opening must communicate directly to the outdoors or to a space that communicates directly with outdoors (NOT to an interior space). • The top of the opening must be within 12 inches of the ceiling. • The free area of the opening must be at least equal to the sum of the areas of all equipment vent connectors in the space. 	
<p>SPECIAL EXCEPTION FOR LARGE SPACES:</p>	<p>NO combustion air openings are needed when the boiler (and other appliances) are installed in a space with a volume NO LESS than 50 cubic feet per 1,000 Btuh of all appliances in the space. That is, total the input of all appliances in MBH (1,000's of Btuh), then multiply this total times 50. The building MUST NOT be of tight construction.</p> <p>Example: For a total input of 1500 MBH (1,500,000 Btuh) and an 8-foot ceiling height, the minimum volume would be 50 x 1500 x 8 = 60,000 cubic feet.</p>	

ADVANCED INSTALLATION

DIRECT EXHAUST — Sidewall

Figure 97 DIRECT EXHAUST — Sidewall termination

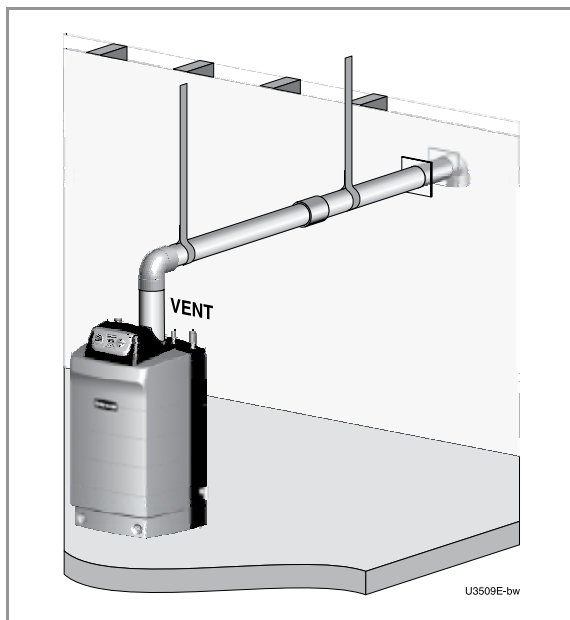

DIRECT EXHAUST — Sidewall termination — installation sequence overview

- Step 1** Install the boiler.
- Step 2** Determine the proper location for wall penetration for each termination.
- Prepare wall penetrations before installing vent piping.
 - Finish by attaching external pipe and fittings as shown in the termination instructions.
 - Support vertical runs on the outside of the building with brackets as shown in the termination instructions.
- Step 3** Install vent piping from boiler to termination.
- Install a hanger support within 6 inches of any upturn in the piping.
 - Install pipe supports every 5 feet on both the horizontal and vertical runs.
 - Slope horizontal piping downward toward the boiler at least 1/4 inch per foot.
- Step 4** Connect the vent piping at the boiler per instructions in this addendum.

Allowable vent pipe materials

1. Use only the materials listed in Figure 13, page 19.
2. Install a bird screen in each vent pipe termination (coupling or elbow). Bird screens are not supplied with the Ultra boiler. Purchase separately from Weil-McLain.

Maximum piping length

1. Locate the termination such that the total vent piping from the boiler to the termination will not exceed the maximum length given in Figure 12, page 18.
2. Maximum lengths listed in Figure 12, page 18 allow for 2 elbows. Additional elbows require a reduction in maximum length as explained in the table notes.

Determine location for sidewall termination

WARNING A gas vent extending through an exterior wall shall not terminate adjacent to the wall or below building extensions such as eaves, parapets, balconies or decks, except as otherwise instructed in this manual or local codes. Failure to comply could result in severe personal injury, death or substantial property damage.

Place the vent terminations using the following guidelines.

3. Terminate the vent piping with a down-turned elbow as shown in Figure 98, page 87. The elbow must butt against the outside wall plate. If vent piping is extended outside, install an elbow at the outer plate and continue vent piping from the elbow when snorkeling as in Figure 98, page 87 right side.
 - a. Apply the configuration on the left side of Figure 98 unless the termination would fail to meet minimum clearance to grade or snow line.
 - b. Apply the configuration on the right side of Figure 98 when the termination needs to be raised higher to meet clearance to grade or snow line.
 - c. The vent pipe may run up as high as 4 feet, as shown in Figure 98 right side, with no enclosure. The vent pipe must be secured with braces, and maintain all required clearances.
 - d. Space braces no further than 24 inches apart. (See WARNING below for extremely cold climates.)
 - e. External venting greater than 4 feet requires an enclosure around the vent pipe. The vent termination must exit through the enclosure as shown in Figure 98, maintaining all required clearances.

WARNING Do not exceed the maximum length of the outside vent piping shown in Figure 98. Excessive length exposed to the outside could cause freezing of condensate in the vent pipe, resulting in potential boiler shutdown. In extremely cold climates, install an insulated chase around the vent piping, particularly when using longer lengths. The chase must allow for inspection of the vent pipe, and insulation must be protected from water.

DIRECT EXHAUST — Sidewall *(continued)*

Figure 98 DIRECT EXHAUST — Sidewall — configuration options and minimum clearances

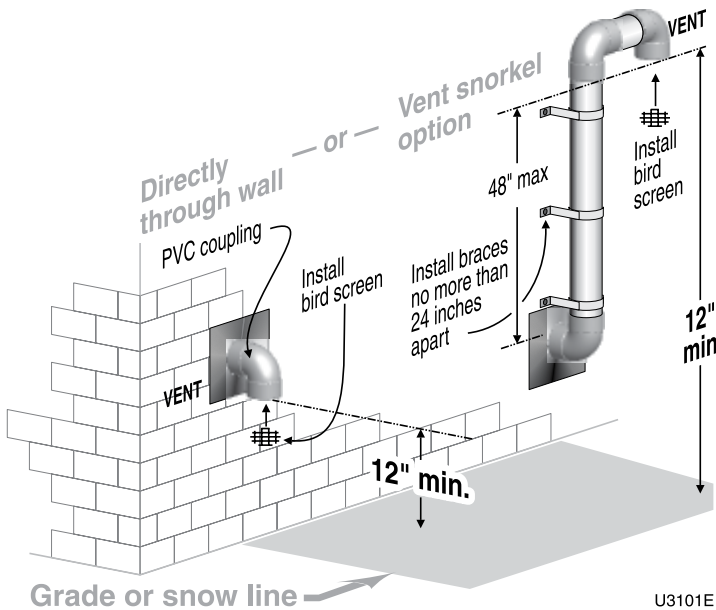
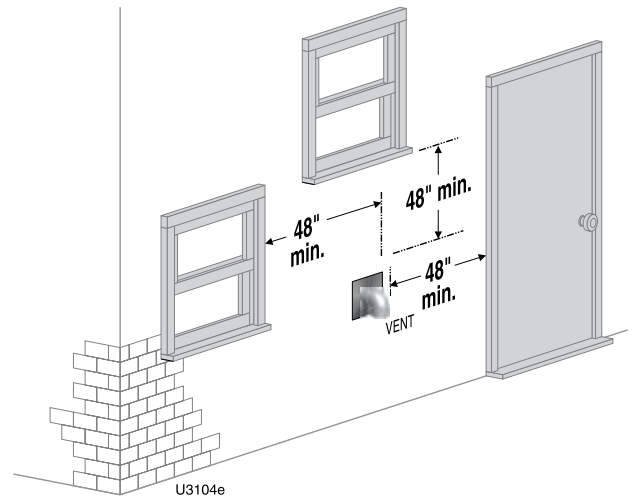
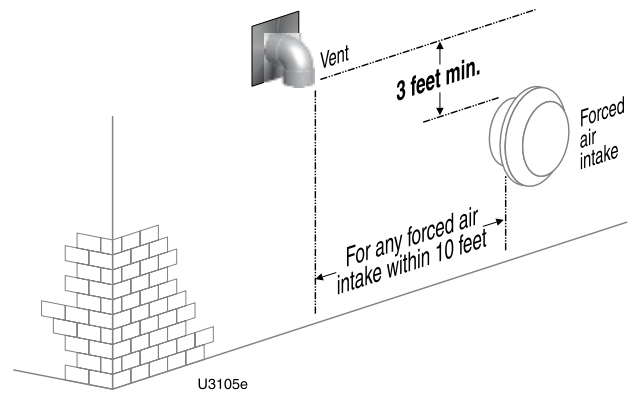

Figure 99 DIRECT EXHAUST — Sidewall — clearances to openings



4. Consider the surroundings when terminating the vent:
 - a. Position the vent termination where vapors will not damage nearby shrubs, plants or air conditioning equipment or be objectionable.
 - b. The flue products will form a noticeable plume as they condense in cold air. Avoid areas where the plume could obstruct window views.
 - c. Prevailing winds could cause freezing of condensate and water/ice buildup where flue products impinge on building surfaces or plants.
 - d. Avoid possibility of accidental contact of flue products with people or pets.
 - e. Do not locate the terminations where wind eddies could affect performance, such as inside building corners, near adjacent buildings or surfaces, window wells, stairwells, alcoves, courtyards or other recessed areas.
 - f. Do not terminate above any door or window or under a deck. Condensate can freeze, causing ice formations.
 - g. Locate or guard vent to prevent condensate damage to exterior finishes.
5. Maintain clearances as shown in the illustrations in this manual section. Also maintain the following:
 - a. Vent must terminate:
 - At least 6 feet from adjacent walls.
 - No closer than 5 feet below roof overhang.
 - At least 3 feet above any forced air intake within 10 feet.
 - No closer than 48 inches below or horizontally from any door or window or any other gravity air inlet.
 - b. Do not terminate closer than 4 feet horizontally from any electric meter, gas meter, regulator, relief valve or other equipment.

Figure 100 DIRECT EXHAUST — Sidewall — clearances from vent exit to forced air intake



6. Because Ultra boilers are Category IV appliances, the National Fuel Gas Code, ANSI Z223.1, requires that the vent must not terminate over a public walkway or over an area where condensate or vapor could create a nuisance or hazard, or could be detrimental to the operation of regulators, relief valves, or other equipment.
7. Where the vent penetrates an outside wall, the annular space around the penetration must be permanently sealed using approved materials to prevent entry of combustion products into the building.



DIRECT EXHAUST — Sidewall *(continued)*

8. Locate termination so it is not likely to be damaged by foreign objects, such as stones or balls, or subject to buildup of leaves or sediment.
9. Do not connect any other appliance to the vent pipe. Do not connect multiple boilers to a common vent pipe.

Completing the vent piping

1. Install vent penetration as explained in the following before installing vent piping from the boiler to the termination.
2. Insert piping from boiler vent connections, then attach exterior termination piping.
3. Follow instructions beginning on page 91 to complete piping from boiler to termination.

Multiple vent terminations

1. When terminating multiple direct exhaust Ultra boilers, terminate each vent connection as described in this manual for individual vents. Space terminations as required for best installation practices and required maintenance.

Prepare wall penetrations

1. Wall penetration:
 - a. Cut a rough opening large enough to clear the diameter of the metal thimble used.
 - b. Provide metal cover plates (item 2, Figure 101). The outer plate **MUST** provide a stop to prevent the vent elbow from being pushed inward. (See NOTICE at right.) Hole diameters in the metal plates must be:
 - 2-inch PVC, CPVC or ABS — 2½" hole diameter.
 - 3-inch PVC, CPVC or ABS — 3⅝" hole diameter.
 - 4-inch PVC, CPVC or ABS — 4⅞" hole diameter.
 - AL29-4C vent pipe and elbow — size hole large enough to clear vent pipe, but small enough to prevent the elbow from being pushed through.
 - c. Insert the galvanized metal thimble (by installer) in the vent pipe hole as shown in Figure 101.
2. Follow all local codes for isolation of vent pipe when passing through floors or walls.

Termination and fittings

1. Prepare the vent termination elbow (Figure 98, page 87) by inserting a bird screen. Bird screens are not supplied with the Ultra boiler. Purchase separately from Weil-McLain.
2. You can install the vent termination using either of the configurations shown in Figure 98, page 87.
3. Maintain the required dimensions of the finished termination piping as shown in Figure 98, page 87.
4. Seal exterior openings thoroughly with exterior caulk.
5. Do not extend exposed vent pipe outside of the building more than shown in this document. Condensate could freeze and block vent pipe.

Figure 101 DIRECT EXHAUST — Sidewall — termination assembly — all parts by installer

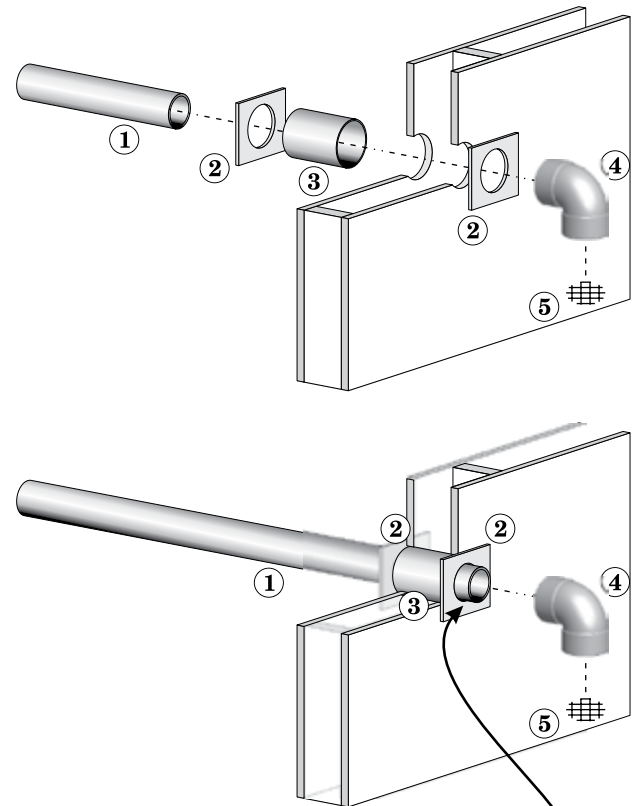

Extend vent pipe through outside plate enough to attach termination coupling (or elbow when snorkeled).

U106e

1 Vent piping	4 Vent termination elbow
2 Cover plates	5 Bird screen
3 Galvanized thimble	

NOTICE The Weil-McLain sidewall termination kit supplied with each boiler includes metal plates with two openings. These plates can be trimmed and used for direct exhaust vent termination cover plates when the vent diameter used matches the hole size in the plates provided with the boiler.

DIRECT EXHAUST — Vertical

Figure 102 DIRECT EXHAUST vertical termination

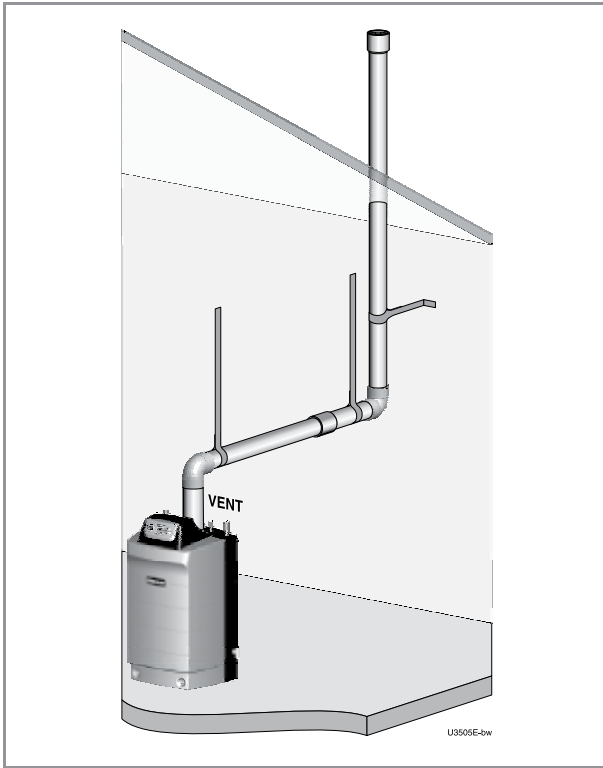

DIRECT EXHAUST — Vertical termination — installation sequence overview

- Step 1** Install the boiler.
- Step 2** Determine the proper location for wall penetration for each termination.
- Prepare roof penetrations before installing vent piping.
 - Finish by attaching external pipe and fittings as shown in the termination instructions.
 - Install terminations as described in this manual.
 - Support vertical runs on the outside of the building with brackets as shown in the termination instructions.
- Step 3** Install vent piping from boiler to termination.
- Install a hanger support within 6 inches of any upturn in the piping.
 - Install pipe supports every 5 feet on both the horizontal and vertical runs.
 - Slope horizontal piping downward toward the boiler at least 1/4 inch per foot.
- Step 4** Connect the vent piping at the boiler per manual instructions.

Allowable vent pipe materials

1. Use only the materials listed in Figure 13, page 19.
2. Install a bird screen in each vent pipe termination (coupling or elbow). Bird screens are not supplied with the Ultra boiler. Purchase separately from Weil-McLain.

Maximum piping length

1. Locate the termination such that the total vent piping from the boiler to the termination will not exceed the maximum length given in Figure 12, page 18.
2. Maximum lengths listed in Figure 12, page 18 allow for 2 elbows. Additional elbows require a reduction in maximum length as explained in the table notes.

Determine location for vertical termination

1. Locate the vent termination using the following guidelines:
 2. The vent piping must terminate in a coupling as shown in Figure 103, page 90.
 3. Consider the surroundings when terminating the vent:
 - a. Position the vent termination where vapors will not damage nearby shrubs, plants or air conditioning equipment or be objectionable.
 - b. The flue products will form a noticeable plume as they condense in cold air. Avoid areas where the plume could obstruct window views.
 - c. Prevailing winds could cause freezing of condensate and water/ice buildup where flue products impinge on building surfaces or plants.
 - d. Avoid possibility of accidental contact of flue products with people or pets.
 - e. Do not locate the termination where wind eddies could affect performance or cause recirculation, such as inside building corners, near adjacent buildings or surfaces, window wells, stairwells, alcoves, courtyards or other recessed areas.
 - f. Locate or guard vent to prevent condensate damage to exterior finishes.
4. Maintain clearances as shown in the illustrations in this manual section. Also maintain the following:
 - a. Vent must terminate:
 - At least 12 inches above roof or snow line as shown in Figure 103.
 - At least 6 feet from adjacent walls.
 - No closer than 5 feet below roof overhang.
 - At least 3 feet above any forced air intake within 10 feet.
 - No closer than 48 inches below or horizontally from any door or window or any other gravity air inlet.
 - b. Do not terminate closer than 4 feet horizontally from any electric meter, gas meter, regulator, relief valve or other equipment.
5. Where the vent penetrates the roof, the annular space around the penetration must be permanently sealed using approved materials to prevent entry of combustion products into the building.
6. Locate terminations so they are not likely to be damaged by foreign objects, such as stones or balls, or subject to buildup of leaves or sediment.
7. Do not connect any other appliance to the vent pipe. Do not connect multiple boilers to a common vent pipe.

DIRECT EXHAUST — Vertical *(continued)*

Prepare roof penetration

- Vent pipe penetration:
 - Cut a hole for the vent pipe. For either combustible or noncombustible construction, size the vent pipe hole at least 0.5" larger than the vent pipe diameter:
 - 3" hole for 2"
 - 4" hole for 3"
 - 5" hole for 4"
 - Insert a galvanized metal thimble in the vent pipe hole.
- Follow all local codes for isolation of vent pipe when passing through floors, ceilings and roofs.
- Provide flashing and sealing boots sized for the vent pipe and air pipe.

Termination and fittings

- Prepare the vent termination coupling (Figure 103) by inserting a bird screen. Bird screens are not supplied with the Ultra boiler. Purchase separately from Weil-McLain.
- The vent piping must terminate in a coupling as shown in Figure 103.
- Maintain the required dimensions of the finished termination piping as shown in Figure 103.
- Do not extend exposed vent pipe outside of building more than shown in this document. Condensate could freeze and block vent pipe.

Multiple vent terminations

- When terminating multiple Ultra boilers, terminate each vent connection as described in this section. Space terminations as required for best installation practices and required maintenance.

Complete termination preparation

- Install vent terminations before proceeding. See previous pages for instructions.

Installing direct exhaust vent piping

- For reference in the following see:
 - Sidewall terminations: see Figure 97, page 86.
 - Vertical terminations: see Figure 102, page 89.
- Work from the boiler to vent or air termination. Do not exceed the lengths given in the previous pages for either the air or vent piping.
 - As shown in the maximum length tables, the Ultra-80 or Ultra-105 may be installed with either 2-inch or 3-inch vent piping.
 - As shown in the maximum length tables, the Ultra-230 may be installed with either 3-inch or 4-inch vent piping.
 - You must install appropriate pipe reducers, where required, at the boiler vent connection.
- See Figure 104 for attaching vent and air pipes at the boiler.
- Cut pipe to required lengths.

Figure 103 DIRECT EXHAUST — Vertical termination

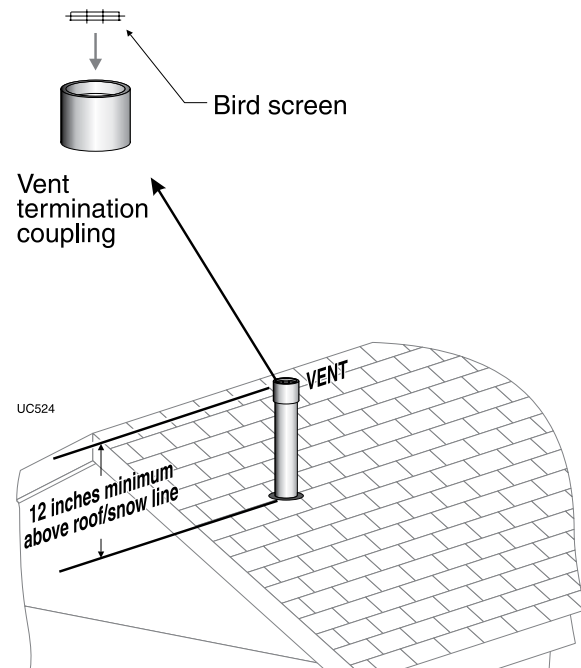

WARNING Sidewall terminations: The vent pipe must extend through the outer cover plate only enough to install the termination elbow. The plate must provide a stop to prevent the vent elbow from being pushed inward.

- Debur inside and outside of pipe ends.
- Chamfer outside of each pipe end to ensure even cement distribution when joining.
- Clean all pipe ends and fittings. Dry thoroughly.
- Dry assemble entire vent or air piping to ensure proper fit before assembling any joint.
- For each joint:
 - Handle fittings and pipes carefully to prevent contamination of surfaces.
 - Apply primer liberally to both joint surfaces — pipe end and fitting socket.
 - While primer is still damp, lightly apply approved cement to both surfaces in a uniform coating.
 - Apply a second coat to both surfaces. Avoid using too much cement on sockets to prevent cement buildup inside.
 - With cement still wet, insert pipe into fitting, twisting 1/4 turn. Make sure pipe is fully inserted.
 - Wipe excess cement from joint. Check joint to be sure a smooth bead of cement shows around the entire joint.
- Install pipe supports as shown in Figure 105, page 92 or Figure 106, page 92.
- Slope vent and air piping continuously toward boiler, with at least 1/4 inch drop per foot of run. Do not allow sags at any point.
- Maintain minimum clearance of 3/16 inch between vent pipe and any combustible wall or material.
- Seal wall or floor penetration openings following local code requirements.

Install vent — from boiler to termination

Figure 104 Boiler vent and air connections

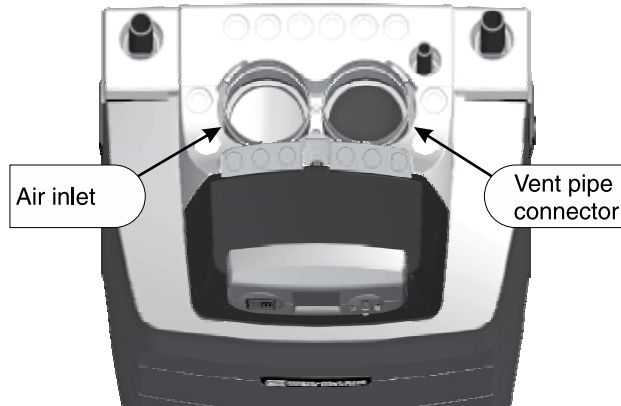

▲WARNING **Air inlet opening protection:** Obtain a bird screen (sized for air inlet opening) the from Weil-McLain. Insert the bird screen into the air inlet opening to prevent foreign objects from falling into the opening.

Inserting/securing vent or air pipe into boiler connectors

▲WARNING AL29-4C vent pipe — If using AL29-4C stainless vent pipe, you must install a PVC-to-vent pipe adapter at the boiler vent connection (and at the termination if using the Weil-McLain plate or the concentric termination). Use only the adapter made by the vent pipe manufacturer.

1. PVC/ABS pipe — Clean and chamfer insertion end of pipe. Deburr inside of insertion end. Clean and deburr inside and outside of other end of pipe.

▲WARNING The pipe end must be smooth and chamfered to prevent possible damage to sealing gasket in vent or air pipe adapter. Failure to comply could result in leakage, causing possible severe personal injury or death.

2. Inspect vent or air adapter (above) — verify no obstructions or foreign objects inside.
3. Loosen clamp screw.
4. Measure 3½ inches from end of pipe and make a mark with felt-tip pen.
5. Loosen adapter clamp screw.
6. Apply small amount of silicon grease to end of pipe to ease insertion.
7. Insert pipe into adapter.
8. Slide pipe down until the 3½-inch mark is reached.

▲WARNING Do not apply excessive force or bend the adapter or flue/air pipe when inserting. The adapter or seal could be damaged.

9. Secure vent or air pipe by tightening the adapter clamp securely. Do not overtighten. The seal is accomplished with the internal gasket. The clamp is only to hold the pipe in place.

Install vent/air piping — boiler to terminations *(cont.)*

Figure 105 Sidewall termination methods and installation requirements

	<p>Weil-McLain sidewall termination plate (install termination — page 70)</p> <ul style="list-style-type: none"> • Install pipe supports every 5 feet on both the horizontal and vertical runs. • Install a hanger support within 6 inches of any upturn in the piping. • The Weil-McLain plate termination must be installed before piping from the boiler to the termination. • Slope horizontal piping downward toward the boiler at least 1/4 inch per foot.
	<p>Weil-McLain 3" or 4" concentric termination (install termination — page 72)</p> <ul style="list-style-type: none"> • Install pipe supports every 5 feet on both the horizontal and vertical runs. • Install a hanger support within 6 inches of any upturn in the piping. • The Weil-McLain 3" PVC concentric termination assembly must be installed before piping from the boiler to the termination. Support the termination at the wall as shown in the termination instructions. • Slope horizontal piping downward toward the boiler at least 1/4 inch per foot. • Rotate the concentric termination Y-fitting about 30° to result in pipe centers the same as at the boiler.
	<p>Sidewall termination with separate vent and air pipes (install termination — page 20)</p> <ul style="list-style-type: none"> • Prepare wall penetrations before installing vent and air piping. Finish by attaching external pipe and fittings as shown in the termination instructions. • Install pipe supports every 5 feet on both the horizontal and vertical runs. • Install a hanger support within 6 inches of any upturn in the piping. • Support vertical runs on the outside of the building with brackets as shown in the termination instructions. • Slope horizontal piping downward toward the boiler at least 1/4 inch per foot.

Figure 106 Vertical termination methods and installation requirements

	<p>Weil-McLain 3" or 4" concentric termination (install termination — page 75)</p> <ul style="list-style-type: none"> • Install pipe supports every 5 feet on both the horizontal and vertical runs. • Install a hanger support within 6 inches of any upturn in the piping. • The Weil-McLain 3" PVC concentric termination assembly must be installed before piping from the boiler to the termination. Support the termination at the ceiling and above the roof as shown in the termination instructions. • Slope horizontal piping downward toward the boiler at least 1/4 inch per foot. • Use long-radius elbows for air piping when using 2" or 3" pipe to reduce pressure drop. • Rotate the concentric termination Y-fitting about 30° to result in pipe centers the same as at the boiler.
	<p>Vertical termination with separate vent and air pipes (install termination — page 23)</p> <ul style="list-style-type: none"> • Prepare roof penetrations before installing vent and air piping. Finish by attaching termination fittings as shown in termination instructions. • Install pipe supports every 5 feet on both the horizontal and vertical runs. • Install a hanger support within 6 inches of any upturn in the piping. • Slope horizontal piping downward toward the boiler at least 1/4 inch per foot. • Air piping may be offset as shown at left so termination can be located as required in the installation instructions. • Use long-radius elbows for air piping when using 2" or 3" pipe to reduce pressure drop.



Gas piping — sizing gas lines

Natural Gas:

Pipe sizing for natural gas

1. Size gas piping from meter outlet to entrance of boiler in accordance with Figure 108 and Figure 109.
2. Use total input of all boilers. Divide total input in Btuh by 1,000 to obtain cubic feet per hour of natural gas.
 - a. Pipe lengths in Figure 108 are equivalent length of straight pipe. Convert pipe fittings to equivalent lengths using data from Figure 107.
 - b. Figure 108 is only for natural gas with specific gravity 0.60, with a pressure drop through the gas piping of 0.30" w.c.
 - c. For additional gas pipe sizing information, refer to ANSI Z223.1 NFPA 54 (or Natural Gas and Propane Installation CAN/CSA B149.1 or B149.2 for Canadian installations).

Natural gas supply pressure

1. Pressure required at gas valve inlet pressure port:
 - a. Maximum: 13" w.c. with no flow (lockup) or with boiler on
 - b. Minimum: 4" w.c. (for all except 5" for -299) with gas flowing (verify during boiler startup, while boiler is at high fire)
2. Install 100% lockup gas pressure regulator in supply line if inlet pressure can exceed 13" w.c. at any time. Adjust lockup regulator for 13" w.c. maximum.

Propane Gas:

⚠WARNING You must follow the instructions, beginning on page 48, to operate the boiler on propane. Failure to comply could result in severe personal injury, death or substantial property damage.

Pipe sizing for propane gas

1. Contact gas supplier to size pipes, tanks and 100% lockup gas pressure regulator.

Propane supply pressure

1. Adjust propane supply regulator provided by gas supplier for 13" w.c. maximum pressure.
2. Pressure required at gas valve inlet pressure port:
 - a. Maximum: 13" w.c. with no flow (lockup) or with boiler on
 - Minimum: 4" w.c. with gas flowing (verify during boiler startup, while boiler is at high fire).

Manifolded gas supply lines

1. Construct gas header for multiple boilers using Figure 107 and the sizing tables below. Refer to the National Fuel Gas Code for other conditions.
2. Provide manual shutoff gas valve and ground joint union as shown in Figure 33, page 29 and Figure 107 for each boiler. When gas line enters from top of the boiler, the boiler internal gas piping provides a drip leg.
3. A 3/4" NPT gas piping riser from header to boiler will be large enough for most jobs. Ensure the piping is large enough so that the minimum pressure at the boiler will be at least 5 inches water column with all connected appliances firing.

Figure 107 Common gas line for multiple boilers

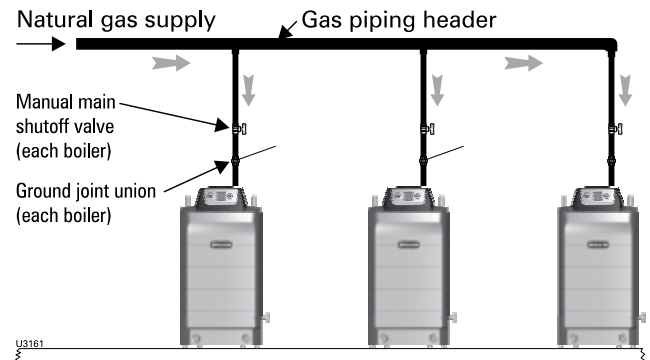

Figure 108 Pipe capacity for 0.60 specific gravity natural gas

Gas pipe total length, feet	Capacity (cubic feet per hour, 0.60 specific gravity)				
	1"	1¼"	1½"	2"	2½"
10	520	1050	1600	3050	4800
20	350	730	1100	2100	3300
30	285	590	890	1650	2700
40	245	500	760	1450	2300
50	215	440	670	1270	2000
75	175	360	545	1020	1650
100	150	305	460	870	1400
150	120	250	380	710	1130

Figure 109 Equivalent lengths of straight pipe for typical gas line fittings

Pipe size inches	Equivalent length, feet	
	90° Elbow	Tee
1	2.62	5.24
1¼	3.45	6.90
1½	4.02	8.04
2	5.17	10.3
2½	6.16	12.3



Field wiring — advanced

⚠ WARNING ELECTRICAL SHOCK HAZARD — For your safety, turn off electrical power supply at service entrance panel before making any electrical connections to avoid possible electric shock hazard. Failure to do so can cause severe personal injury or death.

NOTICE Wiring must be N.E.C. Class 1. If original wiring as supplied with boiler must be replaced, use only type 105 °C wire or equivalent. Boiler must be electrically grounded as required by National Electrical Code ANSI/NFPA 70 – latest edition.

Installation must comply with:

1. National Electrical Code and any other national, state, provincial or local codes or regulations.
2. In Canada, CSA C22.1 Canadian Electrical Code Part 1, and any local codes.

Wiring — general

1. The U-Control provides plug-in, color-coded, non-interchangeable terminal strips for all field wiring. See the schematic diagram (Figure 111, page 96) & ladder diagram (Figure 112, page 97).
2. The U-Control provides programmable flexibility in system operation, allowing control of heat supply for up to three different heating systems. Read this manual thoroughly before connecting the wiring to ensure trouble-free start-up and operation.

Wiring — overview

You will need to make the following connections, some of which depend on your system and how the U-Control will be programmed. (See this and following pages for more information.)

- Connect 120VAC power (minimum 15-amp source)**
- Connect wiring for up to three circulators**
- Connect external limits, if used**
 - Two different circuits are available — The U-Control will require manual reset for one of these circuits. The U-Control will automatically reset after limit operation and re-closure for limits in the other circuit.
- Connect thermostats and/or heat demand contacts**
 - The U-Control can regulate the boiler for up to three different heating systems.
- Connect remote operation input, if used**
 - The U-Control will operate and modulate the boiler based on a 0–10 VDC control signal from a remote controller, when desired.
- Connect the “additional heat demand” circuit to a second heating source, when used**
 - The U-Control allows the boiler to act as the primary or

secondary heat source when another heat source, such as a heat pump or another boiler is available.

- Connect to remote alarm, when used**
- Connect wiring for multiple boiler operation**
 - The U-Control provides the flexibility for control of multiple Ultra boilers.
 - You will need to program the boilers’ U-Controls based on the interconnection method you choose.
- Install system & outdoor sensors, when used**
 - The boiler is shipped with an outdoor sensor, a system supply sensor and a system return sensor. The system supply sensor will be required for most space heating applications. The system return sensor must also be installed when using the system supply sensor. Use of the outdoor sensor is optional.

Line voltage power input

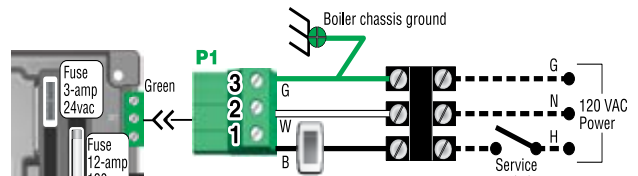

1. Provide and install a fused disconnect or service switch (15-ampere rated recommended) as required by applicable codes.
2. Connect minimum 15-ampere, 120 VAC power wiring to Ultra boiler line voltage terminal strip as shown in Figure 111, page 96 and above.

Wiring circulators

1. The U-Control provides for connection of up to three circulators, one of which must be the boiler circulator. In addition, you can connect a system circulator and a DHW circulator, for examples. See Figure 110, page 95.

⚠ WARNING **The maximum allowable current for each circulator is 2.2 amps at 120 VAC.** For circulators with higher amp ratings, you must install a circulator relay or starter to provide line voltage to the circulator. For circulators rated over 2.2 amps, connect only the circulator relay or starter coil to the Ultra circulator terminals.

2. You can connect any of the circulators you use to any of the three circulator activation terminals. The U-Control setup allows you to assign which circulators activate on a call for heat (this can be customized for each of the heating systems supplied by the boiler).
3. The U-Control factory **default** settings for DHW heating are configured for direct piping to the boiler, with Circulator 1 being the only circulator being activated



Field wiring — advanced (see Figure 111 & Figure 112) *(continued)*

Figure 110 Wiring to circulators

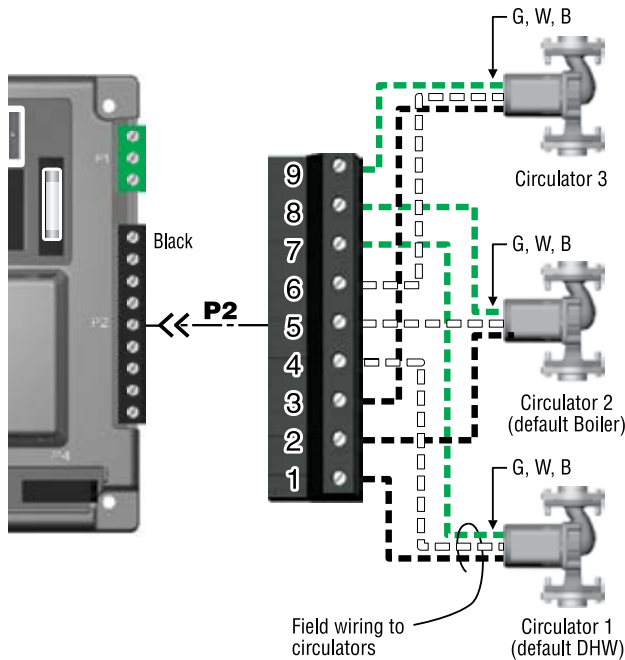

The U-Control module provides internal low water protection

1. The U-Control and internal sensors in the Ultra boiler provide both temperature control and low water protection (using temperature sensors), as explained below:

NOTICE

The U-Control module uses temperature sensors to provide both high limit protection and modulating temperature control.

The U-Control module also provides **low water protection** by using a dual sensor to monitor the temperature of the heat exchanger. [The U-Control constantly monitors the sensor signals to ensure they are within 10 °F of one another. If the sensor difference exceeds 10 °F, the boiler is shutdown on automatic reset.] This method is accepted in many areas as meeting the requirement for a low water cut-off.

Some codes or jurisdictions may require additional external controls for high limit and/or low water cutoff protection. Follow the guidelines in this manual to install additional controls when required.

- during DHW heating. To use factory default settings, make sure to connect the DHW circulator to terminals 1, 4 and 7, as below:
4. The factory **default** for space heating is designed for finned-tube baseboard, and set up to activate Circulator 2 and Circulator 3 on a call for heat. Connect the boiler circulator to terminals 2, 5 and 8 and the system circulator to terminals 3, 6 and 9 to use these default settings.
 5. Make sure the U-Control is programmed to activate the system circulator when it is required (during space heating, for instance).

Thermostats & DHW tank temperature control connections

NOTICE

Use isolating relays if using 3-wire zone valves to avoid damage and nuisance problems due to stray voltage.

1. The U-Control allows operation by up to three different heating systems.
2. The factory default configuration is for “heat demand 1” to be DHW and “heat demand 2” to be space heating. For factory default operation:
 - a. Connect the space heating thermostat to terminal strip P15, terminals 1 and 2 to use the default setup.
 - b. Connect the DHW tank temperature control across terminal strip P11, terminals 4 and 5 to use the default setup.

3. Install thermostats on inside walls away from the influences of drafts, hot or cold water pipes, lighting fixtures, television, sun rays, or fireplaces.
4. Thermostat anticipator (if applicable):
 - If connected directly to the boiler, set anticipator for 0.1 amps.
 - If connected to relays or other devices, set to match total electrical power requirements of connected devices. See device manufacturers’ specifications and the thermostat instructions for details.

Low water cut-offs

1. See the **NOTICE** on this page regarding internal low water protection provided by the U-Control.
2. When an external low water cut-off is installed, connect as shown in the U-Control wiring diagrams (Figure 111, page 96 & Figure 112, page 97).
3. When possible, use the Weil-McLain Ultra low water cut-off kit listed in the back of this manual. It includes a probe-type low water cut-off and provides a simple harness connection for the wiring.

Continued after page 98



Field wiring — advanced (see Figure 111 & Figure 112) (continued)

Figure 112 Ladder wiring diagram — Ultra-80 through Ultra-399

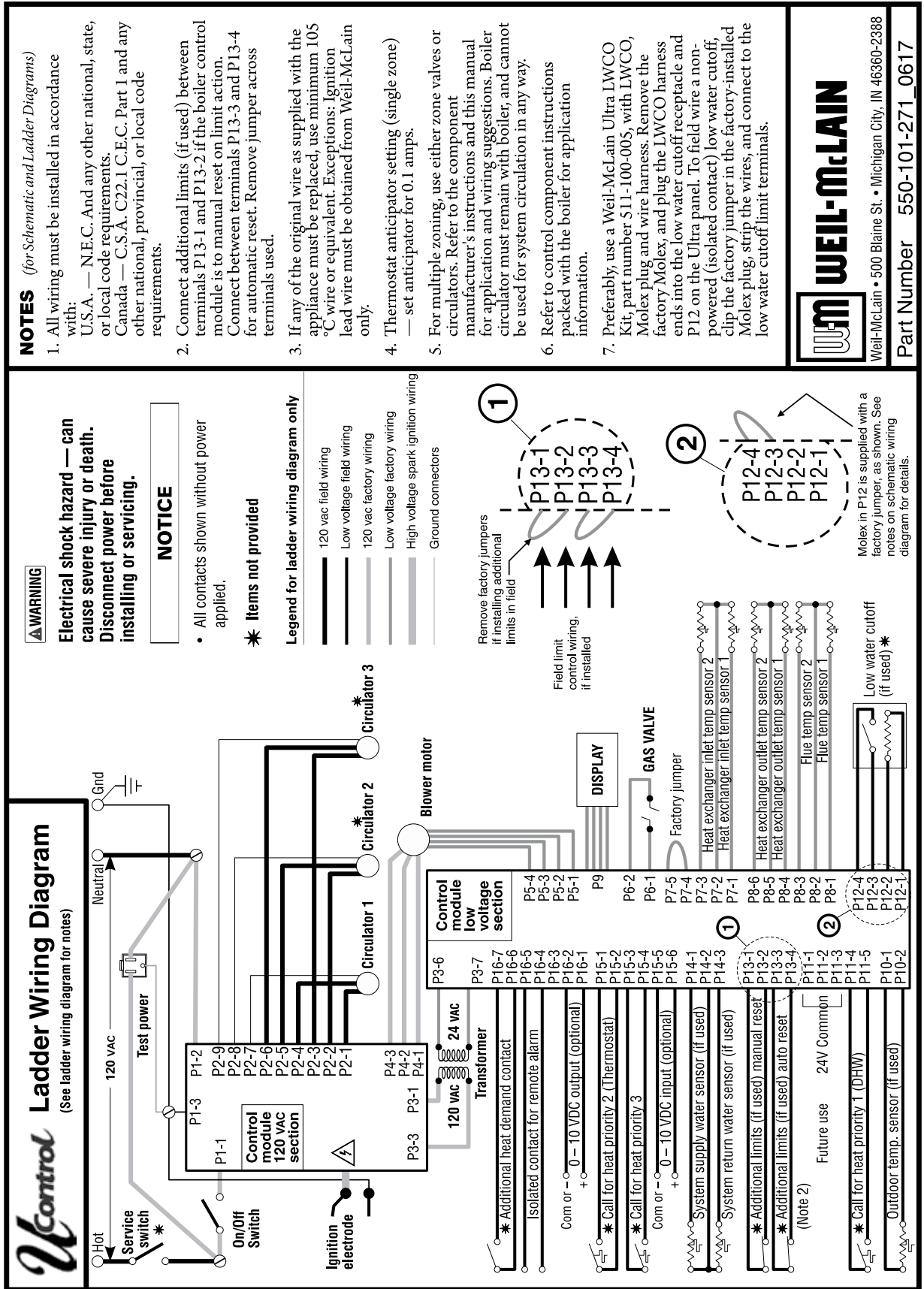

WEIL-McLAIN
Weil-McLain • 500 Blaine St. • Michigan City, IN 46360-2388
Part Number 550-101-271_0617

ADVANCED INSTALLATION

Field wiring — advanced (see Figure 111 & Figure 112) (continued)

Additional limits

1. The U-Control allows connection of external limit controls, both for manual reset and for automatic reset operation of the U-Control.
2. **Manual reset of the U-Control on limit action** — Connect external limits across P13, terminals 1 and 2 if the U-Control is to require manual reset when a limit opens, even if the limit recloses. (Remove the factory jumper when using these terminals.)

NOTICE

The U-Control will lockout when a limit in its manual reset circuit opens. The U-Control activates its alarm terminals and shuts the boiler down until an operator manually resets the U-Control (as explained in this manual). This reset function can be done by a homeowner or a service technician.

3. **Automatic reset of the U-Control on limit action** — Connect external limits across P13, terminals 3 and 4 if the U-Control is to reset automatically when the limit circuit closes after a limit condition. (Remove the factory jumper when using these terminals.)

Remote operation/modulation

1. The U-Control module provides terminals to input a remote 0–10 VDC operating signal. This can be provided by a separate controller if the boiler is configured as Type 4 (SHADOW boiler mode).
2. Connect the 0–10 VDC signal positive terminal to P15 terminal 6, and the signal common to terminal 5.
3. When receiving a remote operating signal, the boiler starts when the signal exceeds 1.0 VDC (and shuts off if the signal drops below 0.5 VDC). The boiler remains at low fire until the signal exceeds 2.0 VDC. Between 2.0 and 10.0 VDC, the boiler firing rate increases with the signal value, reaching full input at 10.0 VDC.
4. The U-Control continues to monitor boiler temperatures, based on the values set up under Priority 1 operation. See the following section for details.

Additional heat demand option

1. The U-Control module can be set up to activate another heat source using its additional heat demand dry contacts (P16, terminals 6 and 7).
2. Connect these terminals to call for heat from the other heat source. (See the following section to program the boiler to activate the other source, either as the primary or secondary heat source.)

Alarm contacts (low voltage ONLY)

1. The U-Control's alarm dry contact (P16, terminals 4 and 5) closes when the boiler enters lockout.
2. Connect these terminals for remote alarm notification.

Multiple boiler wiring options

1. The U-Control can be programmed to sequence multiple boilers or operate/modulate in tandem from a 0–10 VDC source generated by the lead boiler or from a remote controller.
2. See "ADDITIONAL HEAT DEMAND," page 99 for recommended wiring.

Outdoor temperature sensor

1. The U-Control provides programmable options when using an outdoor temperature sensor. This sensor is supplied with the boiler, and can be used if desired (not required). See the following section for outdoor temperature options. **The outdoor sensor must be installed unless specifically exempted in the Energy Act statement on page 137.**
2. Mount the outdoor sensor on an exterior wall, shielded from direct sunlight or flow of heat or cooling from other sources.
3. Connect the sensor leads to P10, terminals 1 and 2, as shown in the wiring diagrams. Thermostat wire can be used to connect the sensor.

System supply & return temperature sensors

(see Figure 4, page 11 for placement of sensors)

1. The boiler is also shipped with two strap-on temperature sensors, intended for system supply and return.
2. These sensors can be attached to piping up to 3-inch diameter.
3. Thermostat wire can be used to connect these sensors.

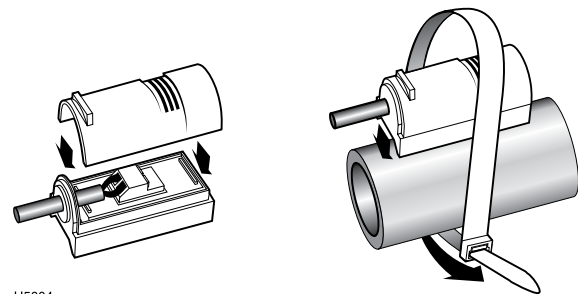

U5004

4. The system supply temperature sensor allows the U-Control to regulate temperature in the system main piping.
5. Locate the supply sensor at least six pipe diameters, but no further than 3 feet, downstream from the boiler connection to the main to ensure adequate mixing.
6. The system return sensor allows the U-Control to monitor and display system return temperature.
7. For multiple boiler applications, install a system supply temperature sensor and system return sensor wired to the LEAD boiler.
8. The U-Control also compares the system return temperature with the system supply temperature. Should the return temperature ever exceed the supply temperature, the U-Control knows there is likely a sensor failure and will report this problem on the display.

U-Control operation and setup — advanced

▲WARNING Low-temperature systems (radiant slab, etc.) — **DO NOT** use the Ultra boiler control as the only means of water temperature regulation for low-temperature systems if higher-temperature systems are also supplied.

ADVANCED SETUP – OVERVIEW

1. Access contractor menus by pressing and holding the UP and DOWN arrow keys at the same time for 5 seconds.
2. The contractor screen will show:
 - a. BOILER SETTINGS
 - b. SYSTEM SETTINGS
 - c. DIAGNOSTICS
 - d. MAINTENANCE INFO
 - e. SET DATE AND TIME
3. Navigate through the menus as shown in Figure 115, page 102. For a description of each of the menu options, see Figure 116, page 104.
4. You will need to adjust settings as required for the systems supplied by the boiler and connect the wiring accordingly.

ADVANCED SETUP – BOILER SETTINGS

BOILER MODEL

▲WARNING Check the **boiler model** against the model listed on the boiler's rating plate. Change the selection to the correct model if not. Also verify the model number on the U-Control display at power-up. Failure to correct could result in severe personal injury, death or substantial property damage.

HIGH ALTITUDE

▲WARNING If the boiler is installed at an altitude above 5,500 feet, select YES for high altitude. The U-Control will automatically adjust firing rates (blower speeds) to compensate for altitude.

WWSD

1. WWSD stands for “warm weather shutdown.” It means the boiler will not be allowed to fire if the outside temperature is greater than the WWSD setting.
2. When the boiler is kept off because the outside temperature is above WWSD, the graphic display will show “WWSD,” and the boiler will remain in standby until the outside temperature drops below WWSD temperature.
3. WWSD does not apply to DHW systems.
4. The outdoor sensor must be installed to use this function.

ADJUST OUTDOOR

1. Use this setting to adjust the outdoor sensor temperature to account for solar or other effects that would cause the sensor to read incorrectly.

ADDITIONAL HEAT DEMAND

1. This setting is for multiple boilers or multiple heating sources (an Ultra boiler collaborating with a heat pump or a different boiler, for examples).
2. For Type 4 boilers, this function only applies to the Priority 1 system.
3. OFF — Function disabled.
4. Type 1 — This means the Ultra boiler is the primary heat source.
 - a. When the Ultra boiler receives a call for heat, it begins its startup sequence and also starts a delay timer (set as ADD'L HEAT DEMAND TIME).
 - b. When the delay timing is reached, the U-Control closes the “Additional heat demand contact,” terminals P16 #6 and #7. Use this contact to start the next heat source.
 - c. If the next heat source is an Ultra boiler, connect this contact to the boiler's “heat demand 1” terminals (P11 #4 and #5). Program the second boiler's delay timer to start a third boiler the same way, and so on to sequentially fire multiple boilers.
5. Type 2 — This means the boiler is the secondary heat source.
 - a. When the U-Control receives a call for heat, it immediately activates the “Additional heat demand contact,” terminals P16 #6 and #7. This contact is used to start the next heat source immediately.
 - b. When the delay timing is reached, the Ultra boiler begins its startup sequence and continues to heat until the demand is satisfied.
 - c. Type 2 assignment would generally only be used if the other heat source is a different boiler or a heat pump, for example.
6. Type 3 — This assigns the boiler as the LEAD boiler in a multiple boiler system.
 - a. This LEAD boiler must have system supply and return sensors mounted on the system supply and return pipes and wired to the boiler.
 - b. When the U-Control receives a call for heat, it begins its heating sequence and starts the additional heat demand delay timer.
 - c. When the delay timing is reached, the U-Control sends a 0–10 VDC proportional signal out its 0–10 VDC output terminals, P16 #1 and #2.
 - d. If the heat demand is satisfied before the timer runs out, the next boiler is not started.
 - e. Connect these output terminals to the SHADOW boilers' 0–10 VDC input terminals, P15 #5 and #6. The SHADOW boilers will start and modulate based on the signal strength. The SHADOW boilers must be set up as Type 4 (see below). They do not need their additional heat timers to be setup.



U-Control operation and setup — advanced *(continued)*

- f. An alternate method is to daisy chain the other boilers. That is, connect the output of each to the input of the next. Each of these boilers would be set up as a Type 4 (see below), and each needs its additional heat timer set for the desired delay between boilers.
7. Type 4 — This assigns the boiler as a SHADOW boiler in a multiple boiler system.
 - a. The boiler can be wired and setup to run in parallel with the other SHADOW boilers as in 6c, above. Or they can be set up for sequential operation following 6d, above.
 - b. When the boiler receives a 0–10 VDC input on terminals P15 #5 and #6, it starts up and modulates firing rate according to the signal.
 - c. If wired and setup per 6d above, it also starts its additional heat delay timer immediately. When the delay timing is reached, the U-Control sends out a 0–10 VDC signal (on terminals P16 #1 and #2) for the next boiler.
 - d. The boiler uses the settings for Priority 1 while receiving the 0–10 VDC signal.

ADVANCED SETUP – PRIORITY 1, 2, 3

1. Priority 1, 2 and 3 refer to the three possible heating inputs that can be handled by the U-Control.
2. Select the priority level desired for the application. Priority 1 is usually assigned to domestic water heating, because of the need for quick response. Priority 2 and 3 usually used for space heating circuits.
3. Each of the three inputs has its own set of operating parameters, programmed using the menus shown in Figure 115, page 102.
4. The inputs to the U-Control are:
 - a. Priority 1 — P11 #4 and #5, “heat demand 1”
 - b. Priority 2 — P15 #1 and #2, “heat demand 2”
 - c. Priority 3 — P15 #3 and #4, “heat demand 3”

ADVANCED SETUP – SYSTEM TYPE

1. For each priority being used, select the appropriate system type. See Figure 114, page 101 for system options and preset temperatures.
2. The temperature presets are chosen based on normal best setting for these systems. The temperature values can be changed, if desired, under “TEMPERATURES.”

ADVANCED SETUP – TEMPERATURES

1. Setup desired temperatures for each of the priorities used.
2. For an explanation of the target temperatures and associated outdoor temperatures, see Figure 113.

- a. Outdoor temp for max target means the outdoor temperature at which the target temperature reaches its maximum value. In the example of Figure 113, this occurs at 25 °F outside.
- b. Outdoor temp for min target means the outdoor temperature at which the target temperature reaches its minimum. In the example of Figure 113, this occurs at 70 °F.
- c. Note that the reset lines are curved. The shape of this curve is matched (or characterized) to the response of the system type chosen to ensure the most effective reset operation.

Figure 113 Typical outdoor reset curves

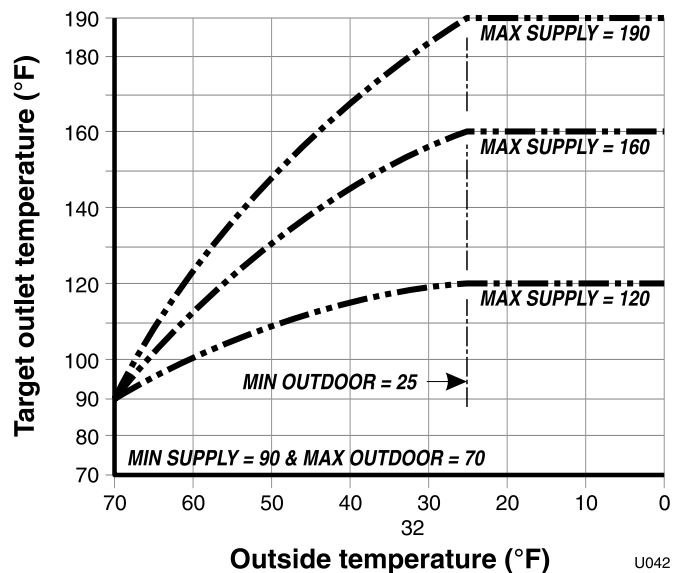

3. **Modulate on differential** — The temperature must drop this many degrees below target temperature for the boiler to come on.
4. **Modulate off differential** — While the boiler is firing, as the temperature increases above the target temperature, the boiler firing rate is reduced. At this many degrees above the target temperature, the boiler shuts down.



U-Control operation and setup — advanced *(continued)*

Figure 114 U-Control system types and preset parameters

System type	Display		Preset temperatures				Note
	8-character	3-char	Max Target Temp	Outdoor Temp for Max Target	Min Target Temp	Outdoor Temp for Min Target	
Fan-coil	FAN-COIL	FCL	190	0	140	70	
Finned tube baseboard	FIN BASE	FTB	180	0	130	70	
Cast iron baseboard	IRN BASE	CIB	180	0	120	70	
Cast iron radiators	RADIATOR	CIR	180	0	120	70	
Radiant – slab on grade	RAD SLAB	RSG	120	0	80	70	
Radiant – thin slab	RAD SLAB	RTS	140	0	80	70	
Radiant – below floor (staple up)	RADFLOOR	RSU	160	0	90	70	
Radiant – above floor (sleeper system)	RADFLOOR	RAF	140	0	90	70	
Custom	CUSTOM	CUS	190	0	70	70	<ul style="list-style-type: none"> • Does not pass along Add'l Heat Demand
DHW – system	DOMESTIC	DHW	190	DHW heating ignores outdoor reset and warm weather shutdown			<ul style="list-style-type: none"> • U-Control modulates to system temperature sensors.
DHW – direct	DOMESTIC	DHW	190				<ul style="list-style-type: none"> • U-Control modulates to boiler temperature sensors. • Does not pass along Add'l Heat Demand

ADVANCED SETUP – CIRCULATOR EXERCISING

1. For each circulator, select whether you want the U-Control to automatically start the circulator and run for 10 seconds for each 72-hour period of inactivity.

ADVANCED SETUP – FREEZE PROTECTION CIRCULATORS

1. This function automatically fires the boiler at low fire and starts the circulators chosen if the heat exchanger sensor detects a temperature less than 40 °F. The circulators turn off when the temperature rises above 45 °F.

ADVANCED SETUP – MAINTENANCE INFO

1. Use this section to enter contractor's information and to enter an automatic notice for maintenance (default is 12 months). Because this shows on the display, it is an automatic means of notifying the homeowner of need for scheduled maintenance by the technician. Update the screen reminder to reset for the next maintenance date.

ADVANCED INSTALLATION



U-Control operation and setup — advanced *(continued)*

Figure 115 U-Control menus *(press and hold the UP and DOWN arrow keys for 5 seconds to enter contractor menus)*

Menus	Next screen	Next screen	Next screen	Next screen	
<i>Follow information at the bottom of each screen to navigate to next/previous screen or enter/save data</i>					
BOILER SETTINGS	BOILER MODEL #####	80 105 155 230	299 399	<div style="background-color: black; color: white; padding: 5px;"> ⚠ WARNING Carefully verify that the boiler model number on the display now agrees with the boiler rating plate. Setting these incorrectly could result in severe personal injury, death or substantial property damage. </div>	
	HIGH ALTITUDE ###	NO YES			
	HIGH TEMP LIMIT	###			
	WSD SETTING ### °F	###			
	ADJUST OUTDOOR ### °F	###			
	ADD'L HEAT DEMAND TYPE: #####	OFF TYPE 1 – ULTRA = PRIMARY HEAT SOURCE TYPE 2 – ULTRA = BACKUP HEAT SOURCE TYPE 3 – ULTRA = LEAD (0–10V OUTPUT) TYPE 4 – ULTRA = SHADOW (0–10V INPUT)			
ADD'L HEAT DEMAND TIME: ### MINUTES	## MINUTES				
SYSTEM SETTINGS	BOILER PRIORITY 1	SYSTEM TYPE: ###		OFF FAN COIL FINNED TUBE BASEBOARD CAST IRON BASEBOARD CAST IRON RADIATOR RADIANT – SLAB ON GRADE RADIANT – THIN SLAB RADIANT – ABOVE FLOOR CUSTOM DHW – DIRECT DHW – SYSTEM	
		TEMPERATURES		MAX SUPPLY: ### °F MIN SUPPLY: ### °F MAX OUTDOOR: ### °F MIN OUTDOOR: ### °F MODULATE ON DIFF: ### °F MODULATE OFF DIFF: ### °F	
		TIMES		MAX ON TIME: ### MIN MIN ON TIME: ### MIN BOOST INTERVAL: ### MIN PRE PUMP TIME: ### SEC POST PUMP TIME: ### SEC	
		CIRCULATORS: # # #		CIRCULATOR 1: ### ON/OFF CIRCULATOR 2: ### ON/OFF CIRCULATOR 3: ### ON/OFF	
		MAXIMUM RATE: ___% MINIMUM RATE: ___%		### % ### %	
	BOILER PRIORITY 2 BOILER PRIORITY 3	SAME MENUS AS FOR PRIORITY 1 SAME MENUS AS FOR PRIORITY 1			
	CIRCULATOR EXERCISING	CIRCULATOR 1: ### CIRCULATOR 2: ### CIRCULATOR 3: ###		ON/OFF ON/OFF ON/OFF	
	FREEZE PROTECT CIRCS	CIRCULATOR 1: ### CIRCULATOR 2: ### CIRCULATOR 3: ###		ON/OFF ON/OFF ON/OFF	
	MAINTENANCE INFO	NAME	#####		
		PHONE MODEL CP# INSTALLED LAST DATE NEXT DATE INTERVAL SETTINGS RESET REMINDER	###-###-#### ULTRA ##### ##### MM/DD/YY MM/DD/YY DD/MM/YY ## MONTHS PRESS ENTER TO RESET		



U-Control operation and setup — advanced *(continued)*

Figure 115 U-Control menus, continued *(press and hold the UP and DOWN arrow keys for 5 seconds to enter contractor menus)*

Menus	Next screen	Next screen	Next screen	Next screen
<i>Follow information at the bottom of each screen to navigate to next/previous screen or enter/save data</i>				
SET DATE AND TIME	SET YR/MN/DAY/HR/MIN			
DIAGNOSTICS	TEMPERATURES	STATUS: ##### SYSTEM SUPPLY: ###°F SYSTEM RETURN: ###°F BOILER OUT1: ###°F BOILER OUT2: ###°F BOILER IN1: ###°F FLUE 1: ###°F FLUE 2: ###°F OUTDOOR: ###°F		
	INPUTS	STATUS: ##### PRIORITY 1: ### PRIORITY 2: ### PRIORITY 3: ### ANALOG IN: ### MANUAL LIMIT: ##### AUTO LIMIT: ##### LOW WTR CUTOFF: ##### BLOWER TACH: ####RPM FLAME SIGNAL: ###		
	OUTPUTS	STATUS: ##### GAS VALVE: ### CIRCULATOR 1: ### CIRCULATOR 2: ### CIRCULATOR 3: ### BLOWER SIGNAL: ###% ADD'L HEAT DEMAND: ### ALARM: ### ANALOG OUT: #####		
	ERRORS	CONTROL FAULT ### IGNITION RETRIES ###		
		MANUAL RESET CNT ### AUTO RESET CNT ###		
		LOCKOUT HISTORY 1	LOCKOUT HISTORY # HH:MM AM MM/DD/YY STATUS: ##### MANUAL RESET AUTO RESET INPUTS OUTPUTS TEMPERATURES	LIST OF LOCKOUTS LIST OF LOCKOUTS INPUT STATUS OUTPUT STATUS TEMPERATURES
		LOCKOUT HISTORY 2 LOCKOUT HISTORY 3	. . . SAME AS HISTORY 1 . . . SAME AS HISTORY 1	
	SOFTWARE VERSIONS	DISPLAY V#.# MAIN MICRO V#.# SECOND MICRO V#.#	NOTE: Display will show C#.# for CSD-1 control.	
MANUAL TEST MODE	STATUS: ##### TARGET: ###°F MODULATION: ###°F SYSTEM SUPPLY: ###°F SYSTEM RETURN: ###°F BOILER OUT: ###°F BOILER IN: ###°F FLAME SIGNAL: ### BLOWER SIGNAL: ###% BLOWER TACH: ####RPM FORCE RATE AUTO			
MANUAL RESET	PRESS ENTER TO RESET THE FOLLOWING ERROR (SCREEN SHOWS A LIST OF ERRORS)			

ADVANCED INSTALLATION



U-Control operation and setup — advanced *(continued)*

Figure 116 U-Control setup options (see Figure 115, page 102 for location in menu sequence)

Menu/Item	Units	Low Value	High Value	Default	Comment
Boiler Settings					
Boiler Model	80, 105, 155, 230, 299, 399			factory	THIS MUST BE SET CORRECTLY FOR SAFE OPERATION. Adjusts blower speeds and flame sense (Display will show "HA" after the model number if high altitude has been selected, below.)
High Altitude	yes or no			no	Adjusts ignition and low fire fan speed (for altitudes above 5,500 feet only)
High Limit	°F	50	200	200	If boiler out temperature reaches this temperature boiler will lockout which requires a manual reset
WWSD Temp	°F	Off, 50	100	70	Boiler will not respond to heating calls above this outdoor temp
Adjust Outdoor	°F (difference)	-10	+10	0	This value plus outdoor sensor reading equals outdoor temp (Use this setting to compensate for solar gain or other factors that cause a shift in sensor temperature.)
Add'l Heat Demand Type	Types	Off	Type 4	Off	Type 1 — Ultra is primary source, starts secondary after delay (requires system sensors) Type 2 — Ultra is secondary source, starts primary immediately Type 3 — Boilers operate in parallel, Ultra boiler is LEAD, outputs 0–10 VDC to others Type 4 — Boilers operate in parallel, Ultra boiler is SHADOW, receives 0–10 VDC input
Add'l Heat Demand Time	minutes	0	240	0	Delay before bringing on additional heating appliances
System Settings					
Boiler Priority 1					
System Type	Types	Off	Custom	DHW - direct	DHW-direct doesn't use ODR, boost, or Add'l heat demand output
Max Supply	°F	60	190	190	Boiler enters manual reset lockout at 200°F
Min Supply	°F	60	190	N/A	N/A - DHW does not use reset
Max OD Reset	°F	50	100	N/A	N/A - DHW does not use reset
Min OD Reset	°F	-20	50	N/A	N/A - DHW does not use reset
Modulate On Diff	°F	2	10	5	Boiler turns on if temperature drops below target minus differential on
Modulate Off Diff	°F	2	10	5	Boiler shuts down if modulates past target plus differential off
Max On Time	minutes	off	240	30	Longest time boiler will satisfy this system before switching to an active lower priority
Min On Time	—	—	—	—	Priority 1 does not have this setting
Boost Interval	minutes	off	240	N/A (not used)	When operating on ODR increases target 10F when this time expires until reaching MAX
Prepump Time: ### SEC	seconds	0	240	20	Additional time to run circulators longer than standard 10 second time
Postpump Time: ### SEC	seconds	off	240	30	Circulator run time after call for heat ends
Circulator 1	on-off	off	on	on	Circulator activates on this call for heat if on
Circulator 2	on-off	off	on	off	Circulator activates on this call for heat if on
Circulator 3	on-off	off	on	off	Circulator activates on this call for heat if on
Maximum Rate	%Rate	21%	100%	96%	Boiler Model and altitude specific (derated to 96% from factory) NOTE: Adjusting boiler firing rate will affect AFUE rating.
Minimum Rate	%Rate	20%	99%	33% (80-299) 20% (399)	Boiler Model and altitude specific
Boiler Priority 2					
System Type	Types			FTB	Finned-Tube Baseboard
Max Supply	°F	60	190	180	Highest target the control will calculate based on outdoor temperature Target temperature if outdoor sensor is not detected (manual reset lockout at 200°F)
Min Supply	°F	60	190	130	Lowest target the control will calculate based on outdoor air temperature
Max OD Reset	°F	50	100	70	Outdoor air temperature that forces the minimum supply water to be target temperature
Min OD Reset	°F	-20	50	0	Outdoor air temperature that forces the maximum supply water to be target temperature
Modulate On Diff	°F	2	10	5	Boiler turns on if temperature drops below target minus differential on
Modulate Off Diff	°F	2	10	5	Boiler shuts down if modulates past target plus differential off



U-Control operation and setup — advanced *(continued)*

Figure 116 U-Control setup options (see Figure 115, page 102 for location in menu sequence), continued

Menu/Item	Units	Low Value	High Value	Default	Comment
Max On Time	minutes	off	240	30	Longest time boiler will satisfy this system before switching to an active lower priority
Min On Time	minutes	off	240	15	Time boiler will satisfy this system before switching to the next active priority
Boost Interval	minutes	off	240	off	When operating on ODR increase target 10F when this time expires until reaching MAX
Prepump Time: ### SEC	seconds	0	240	20	Additional time to run circulators longer than standard 10 second time
Postpump Time: ### SEC	seconds	off	240	30	Circulator run time after call for heat ends
Circulator 1	on-off	off	on	off	Circulator activates on this call for heat if on
Circulator 2	on-off	off	on	on	Circulator activates on this call for heat if on
Circulator 3	on-off	off	on	on	Circulator activates on this call for heat if on
Maximum Rate	%Rate	21%	100%	96%	Boiler Model and altitude specific (derated to 96% from factory) NOTE: Adjusting boiler firing rate will affect AFUE rating.
Minimum Rate	%Rate	20%	99%	33% (80-299) 20% (399)	Boiler Model and altitude specific
Boiler Priority 3					
System Type	Types			Custom	
Max Supply	°F	60	190	190	Highest target the control will calculate based on outdoor temperature Target temperature if outdoor sensor is not detected (manual reset lockout at 200°F)
Min Supply	°F	60	190	70	Lowest target the control will calculate based on outdoor air temperature
Max OD Reset	°F	50	100	70	Outdoor air temperature that forces the minimum supply water to be target temperature
Min OD Reset	°F	-20	50	0	Outdoor air temperature that forces the maximum supply water to be target temperature
Modulate On Diff	°F	2	10	5	Boiler turns on if temperature drops below target minus differential on
Modulate Off Diff	°F	2	10	5	Boiler shuts down if modulates past target plus differential off
Max On Time	—	—	—	—	Priority 3 does not have this setting
Min On Time	minutes	off	240	15	Time boiler will satisfy this system before switching to the next active priority
Boost Interval	minutes	off	240	off	When operating on ODR increase target 10F when this time expires until reaching MAX
Prepump Time: ### SEC	seconds	0	240	20	Additional time to run circulators longer than standard 10 second time
Postpump Time: ### SEC	seconds	off	240	30	Circulator run time after call for heat ends
Circulator 1	on-off	off	on	on	Circulator activates on this call for heat if on
Circulator 2	on-off	off	on	on	Circulator activates on this call for heat if on
Circulator 3	on-off	off	on	on	Circulator activates on this call for heat if on
Maximum Rate	%Rate	21%	100%	96%	Boiler Model and altitude specific (derated to 96% from factory) NOTE: Adjusting boiler firing rate will affect AFUE rating.
Minimum Rate	%Rate	20%	99%	33% (80-299) 20% (399)	Boiler Model and altitude specific
Circulator Exercising					
Circulator 1	on-off	off	on	on	Circulators exercise 10 seconds every 72 hours of inactivity if on
Circulator 2	on-off	off	on	on	Circulators exercise 10 seconds every 72 hours of inactivity if on
Circulator 3	on-off	off	on	on	Circulators exercise 10 seconds every 72 hours of inactivity if on
Freeze Protect Circs					
Circulator 1	on-off	off	on	off	If HxOut sensor out falls below 40F boiler fires low and turns on this circ until 45F
Circulator 2	on-off	off	on	on	If HxOut sensor out falls below 40F boiler fires low and turns on this circ until 45F
Circulator 3	on-off	off	on	off	If HxOut sensor out falls below 40F boiler fires low and turns on this circ until 45F



U-Control operation and setup — advanced *(continued)*

Figure 117 U-Control diagnostic information (see Figure 115, page 102 for location in menu sequence)

Menu/Item	Units	Low Value	High Value	Default	Comment
Diagnostics					
Temperatures					
Status	Text			data	Current operating status of the boiler. Prepurge, Ignition, Name of the system Type being satisfied, post purge, Warm Weather Shutdown, Trouble
System Supply	°F			data	Temperature of the remote system supply sensor
System Return	°F			data	Temperature of the remote system return sensor
Boiler Out1	°F			data	Temperature of the first sensing element of the boiler's heat exchanger outlet sensor
Boiler Out2	°F			data	Temperature of the second sensing element of the boiler's heat exchanger outlet sensor
Boiler In1	°F			data	Temperature of the boiler's heat exchanger inlet sensor
Flue1	°F			data	Temperature of the first sensing element of the boiler's flue gas sensor
Flue2	°F			data	Temperature of the second sensing element of the boiler's flue gas sensor
Outdoor	°F			data	Temperature of the remote outdoor air temperature sensor
Inputs					
Status	Text			data	Current operating status of the boiler. Prepurge, Ignition, Name of the system Type being satisfied, post purge, Warm Weather Shutdown, Trouble
Priority 1	on-off			data	Call for heat status on Priority 1 Input
Priority 2	on-off			data	Call for heat status on Priority 2 Input
Priority 3	on-off			data	Call for heat status on Priority 3 Input
Analog Input	vdc			data	Value of 0–10 VDC input signal on P15 #5 and #6
Manual Limit	open-closed			data	External manual limit P13-1 & P13-2
Auto Limit	open-closed			data	External auto limit P13-3 & P13-4
Low Wtr Cutoff	open-closed			data	Low water cutoff device on P12-3 & P12-4
Blower Tach	rpm			data	Feedback from blower sensor
Flame Signal	no units			data	Number indicating the presence and quality of the flame used to shutdown boiler
Outputs					
Gas Valve	on-off			data	Control's gas valve circuit status
Circulator 1	on-off			data	Control's circulator 1 relay status
Circulator 2	on-off			data	Control's circulator 2 relay status
Circulator 3	on-off			data	Control's circulator 3 relay status
Blower Signal	% of rate			data	Control's signal controlling the blower speed
Add'l Heat Demand	on-off			data	Control's signal controlling the additional heat demand
Alarm	on-off			data	Control's alarm contact status
Analog Output	vdc			data	Value of 0–10 VDC output signal on P16 #1 and #2
Errors					
Control Fault	#			0	Displays number of control faults
Ignition Retries	#			0	Displays number of ignition attempts boiler is currently on
Manual Reset Cnt	#			0	Displays number of manual reset lockouts since last cleared
Auto Reset Cnt	#			0	Displays number of auto reset lockouts since last cleared
Lockout History 1					Choose this to view the most recent error recorded
Time & Date	text			data	Displays time and date that lockout occurred
Status	text			data	Displays what the status of the boiler at the time of the error
Manual Reset	yes or none			data	Choose this to view the details of manual reset lockouts
Auto Reset	yes or none			data	Choose this to view the details of auto reset lockouts
Inputs	menu			menu	Choose this to view the status of the Boiler Inputs at the time of the error
Outputs	menu			menu	Choose this to view the status of the Boiler Outputs at the time of the error
Temperatures	menu			menu	Choose this to view the Boiler Temperatures at the time of the error
Lockout History 2					Choose this to view the second most recent error recorded
Time & Date	text			data	Displays time and date that lockout occurred
Status	text			data	Displays what the status of the boiler at the time of the error



U-Control operation and setup — advanced *(continued)*

Figure 117 U-Control diagnostic information (see Figure 115, page 102 for location in menu sequence), continued

Menu/Item	Units	Low Value	High Value	Default	Comment
Manual Reset	yes or none			data	Choose this to view the details of manual reset lockouts
Auto Reset	yes or none			data	Choose this to view the details of auto reset lockouts
Inputs	menu			menu	Choose this to view the status of the Boiler Inputs at the time of the error
Outputs	menu			menu	Choose this to view the status of the Boiler Outputs at the time of the error
Temperatures	menu			menu	Choose this to view the Boiler Temperatures at the time of the error
Lockout History 3					Choose this to view the third most recent error recorded
Time & Date	text			data	Displays time and date that lockout occurred
Status	text			data	Displays what the status of the boiler at the time of the error
Manual Reset	yes or none			data	Choose this to view the details of manual reset lockouts
Auto Reset	yes or none			data	Choose this to view the details of auto reset lockouts
Inputs	menu			menu	Choose this to view the status of the Boiler Inputs at the time of the error
Outputs	menu			menu	Choose this to view the status of the Boiler Outputs at the time of the error
Temperatures	menu			menu	Choose this to view the Boiler Temperatures at the time of the error
Software Versions					
Display	### format			data	Software version of the microprocessor on the display circuit board
Main Micro	### format			data	Software version of the main microprocessor on the control circuit board
Second Micro	### format			data	Software version of the second microprocessor on the control circuit board
Manual Test Mode					
Status	text			data	Current operating status of the boiler. Prepurge, Ignition, Name of the system Type being satisfied, post purge, Warm Weather Shutdown, Trouble
Target	°F			data	Calculated target temperature based on outdoor temp or the max setpoint if no ODR
Modulation	°F			data	Temperature of the sensor the boiler is using to base its modulation
System Supply	°F			data	Temperature of the remote mounted system water supply sensor
System Return	°F			data	Temperature of the remote mounted system water return sensor
Boiler Out	°F			data	Temperature of the outlet sensor on the boiler heat exchanger
Boiler In	°F			data	Temperature of the inlet sensor on the boiler heat exchanger
Flame Signal	no units			data	Number indicating the presence and quality of the flame used to shutdown boiler
Blower Signal	% of rate			data	Control's output to the blower
Blower Tach	rpm			data	Blower's feedback to the control
Force Rate		Low, Med, High, or Auto		Auto	Used to manually force a rate during a call for heat. Choose auto for normal operation.
Manual Reset					Reset selected condition
Maintenance Info					
Name	text			blank	Contractor name to appear in maintenance reminders and during lockouts
Phone	text			blank	Contractor phone number
Model	text			blank	Displays the boiler model selected in the boiler setup
CP Number	text			blank	Enter the CP# of the boiler
Installed	text			blank	Enter the date the boiler was installed
Last Date	text			data	Date automatically entered when Reset Reminder is choose by contractor
Next Date	text			data	Date automatically calculated when Reset Reminder is selected by contractor
Interval Settings	months	6	24	12	Contractor selects maintenance reminder frequency based on service history
Reset Reminder	menu			menu	Contractor selects this to update Last maintenance Date and Next Date. Homeowner uses this to ignore the reminder and update only the Next Date.
Set Time and Date					
Year	text			2017	Set year (homeowner or contractor)
Month	text			1	Set month (homeowner or contractor)
Day	text			1	Set day (homeowner or contractor)
Hour	text			12	Set hour (homeowner or contractor)
Minute	text			0	Set minute (homeowner or contractor)



Annual startup and general maintenance

WARNING Follow the service and maintenance procedures given throughout this manual and in component literature shipped with the boiler. Failure to perform the service and maintenance could result in damage to the boiler or system. Failure to follow the directions in this manual and component literature could result in severe personal injury, death or substantial property damage.

Figure 118 Service and maintenance schedules

Service technician (see following pages for instructions)		Owner maintenance (see Ultra User's Information Manual for instructions)	
ANNUAL START-UP (See First-year special inspection)	General:	Daily	<ul style="list-style-type: none"> Check boiler area. Check air openings. Check pressure/temperature gauge. Verify boiler front door is securely in place.
	<ul style="list-style-type: none"> Reported problems. Inspect interior; clean and vacuum if necessary; WARNING — no solvents. Clean condensate trap and fill with fresh water. Check for leaks (water, gas, flue, condensate). Check system water chemistry, inhibitor level and antifreeze concentration. Verify flue and air lines in good condition and sealed tight. Check system water pressure/system piping/expansion tank. Check control settings. Ignition electrode (clean with steel wool and reposition) — replace if worn. Ignition and ground wiring. Wiring and connections. Perform start-up checkout and performance verification beginning with Startup — fill the system, page 35. Flame inspection (stable, uniform). Flame signal (see Figure 119, page 112). Clean Nanogate coated heat exchanger if flue temp is more than 54°F above return water temp. Inspect jacket front door gaskets; replace if necessary. 	<ul style="list-style-type: none"> Check vent piping. Check air piping. Check relief valve. Check condensate drain system. Check automatic air vents (if used). 	
	Additional if combustion or performance indicate need:	Monthly	<ul style="list-style-type: none"> Test low water cutoff (if used).
	<ul style="list-style-type: none"> Clean heat exchanger, page 126 Remove and clean burner using compressed air only. Vacuum the blower. 	<ul style="list-style-type: none"> Check boiler piping (gas and water) Operate relief valve. 	
	Review:	Periodically	<ul style="list-style-type: none"> Shut boiler down (unless boiler used for domestic water).
<ul style="list-style-type: none"> Review with owner. 	Every 6 months		
	End of season		

Annual startup

HANDLING CERAMIC FIBER MATERIALS

REMOVING BURNER GASKET or COVER PLATE INSULATION

▲WARNING The Ultra burner gasket (models 80 and 105) and cover plate insulation (all models) contain ceramic fiber material. Ceramic fibers can be converted to cristobalite in very high temperature applications. The International Agency for Research on Cancer (IARC) has concluded, “Crystalline silica inhaled in the form of quartz or cristobalite from occupational sources is carcinogenic to humans (Group 1).”:

- Avoid breathing dust and contact with skin and eyes.
- Use NIOSH certified dust respirator (N95). This type of respirator is based on the OSHA requirements for cristobalite at the time this document was written. Other types of respirators may be needed depending on the job site conditions. Current NIOSH recommendations can be found on the NIOSH web site at <http://www.cdc.gov/niosh/homepage.html>. NIOSH approved respirators, manufacturers, and phone numbers are also listed on this web site.
- Wear long-sleeved, loose fitting clothing, gloves, and eye protection.
- Apply enough water to the combustion chamber lining or base insulation to prevent airborne dust.
- Remove combustion chamber lining or base insulation from the boiler and place it in a plastic bag for disposal.
- Wash potentially contaminated clothes separately from other clothing. Rinse clothes washer thoroughly.

NIOSH stated First Aid

- Eye: Irrigate immediately
- Breathing: Fresh air.

FIRST-YEAR SPECIAL INSPECTION

NOTICE

It is recommended that you obtain a Weil-McLain Ultra Boiler Maintenance kit before attempting the first-year inspection, to ensure all parts that may be needed are available. This kit includes a heat exchanger cover plate gasket, burner gasket (80 and 105 only), new ignitor, and ignitor gasket. See listing in Replacement parts section of this manual. These parts must be on hand when you perform the first-year inspection in the event they must be replaced.

▲WARNING

Failure to replace the items above when needed could result in severe personal injury, death or substantial property damage.

1. **No later than 12 months** after the boiler is installed, perform a first-year inspection of the boiler. This must include the following **in addition to routine annual start-up procedures**.
 - a. Remove the heat exchanger cover plate (see page 112 for instructions on removal and replacement).
 - b. Inspect the heat exchanger and clean if necessary (see “Cleaning the heat exchanger — pin side when required,” page 125, and all referenced illustrations and instructions).
 - c. Inspect the cover plate insulation and gasket. Replace if not in good condition.
 - d. Remove the burner and inspect carefully. Clean the burner thoroughly using a vacuum cleaner and a soft brush if needed. Make sure there is no blockage or accumulation of debris in the burner or the burner ports. Replace the burner if necessary.
 - e. Models 80 and 105 only — inspect the burner gasket, and replace if the gasket is not in good condition. Make sure the burner is clean. Then securely fasten it tightly to the cover plate.
 - f. Disconnect condensate trap and drain lines. Inspect, then flush thoroughly.
2. Determine follow-up maintenance and service needs based on the condition of the heat exchanger and condensate lines.
 - a. If the heat exchanger shows substantial fouling, or if condensate lines show accumulation of sediment, schedule a follow-up service call to perform the first-year inspection again, sooner than the normal twelve months between.
 - b. Heavy fouling of the exchanger or condensate lines indicates possible combustion air contamination. Inspect the air intake area carefully, and remove possible contaminants. See Figure 11, page 16, for products to avoid.

▲WARNING

You must eliminate causes of corrosion and contamination to ensure reliable operation of the boiler and system.



Annual startup *(continued)*

▲WARNING The boiler should be inspected and started annually, at the beginning of the heating season, only by a qualified service technician. In addition, the maintenance and care of the boiler designated in Figure 118, page 108 and explained on the following pages must be performed to assure maximum boiler efficiency and reliability. Failure to service and maintain the boiler and system could result in equipment failure.

▲WARNING Electrical shock hazard— Turn off power to the boiler before any service operation on the boiler except as noted otherwise in this instruction manual. Failure to turn off electrical power could result in electrical shock, causing severe personal injury or death.

Address reported problems

1. Inspect any problems reported by owner and correct before proceeding.

Inspect boiler area

1. Verify that boiler area is free of any combustible materials, gasoline and other flammable vapors and liquids.
2. Verify that air intake area is free of any of the contaminants listed on page 16 of this manual. If any of these are present in the boiler intake air vicinity, they must be removed. If they cannot be removed, reinstall the air and vent lines per this manual.

Inspect boiler interior & door gaskets

1. Remove jacket front door and inspect interior of boiler.
2. Visually inspect the door gaskets. Make sure all are in good condition. Obtain replacements if any gasket is damaged.

▲WARNING Door gaskets must be intact, and must provide a reliable seal. Replace any damaged gasket.

3. Remove the venturi air inlet silencer and clean if necessary. Replace silencer.
4. Vacuum any sediment from the inside of the boiler and components. Remove any obstructions.

▲WARNING Do not use solvents to clean any of the boiler components. The components could be damaged, resulting in unreliable or unsafe operation.

Clean condensate trap

1. Loosen condensate trap line hose clamps and remove trap line.
2. Empty water from trap line and inspect. Flush out if needed with fresh water.
3. Check condensate elbow and tee and condensate line to drain. Flush if necessary to clean.
4. Reinstall condensate trap line and tighten hose clamps.
5. Fill trap with fresh water by pouring into upturned end of PVC condensate tee.

Check all piping for leaks

▲WARNING Eliminate all system or boiler leaks. Continual fresh make-up water will reduce boiler life. Minerals can build up in sections, reducing heat transfer, overheating heat exchanger, and causing heat exchanger failure. Leaking water may also cause severe property damage.

1. Inspect all water and gas piping and verify to be leak free.
2. Look for signs of leaking lines and correct any problems found.
3. Check gas line using procedure on page 29.

Check air openings

1. Verify that combustion and ventilation air openings to the boiler room and/or building are open and unobstructed. Check operation and wiring of automatic combustion air dampers, if used.
2. Verify that boiler vent discharge and air intake are clean and free of obstructions.

Flue vent system and air piping

1. Visually inspect entire flue gas venting system and combustion air piping for blockage, deterioration or leakage. Repair any joints that show signs of leakage in accordance with vent manufacturer's instructions. When air is ducted to boiler, verify that air inlet hose is connected and properly sealed.

▲WARNING Failure to inspect for the above conditions and have them repaired can result in severe personal injury or death.

Check water system

1. Verify all system components are correctly installed and operational.
2. Check the cold fill pressure for the system. Verify it is correct (usually around 12 psig).
3. Watch the system pressure as the boiler heats up (during testing) to ensure pressure doesn't rise too high. Excessive pressure rise indicates expansion tank sizing or performance problem.

Annual startup *(continued)*

4. Inspect automatic air vents and air separators. Remove air vent caps and briefly press push valve to flush vent. Reinstall caps. Make sure vents do not leak. Replace any leaking vents.
5. Check system water chemistry (pH, hardness and inhibitor level). See page 35.

Check expansion tank

1. Expansion tanks provide space for water to move in and out as the heating system water expands due to temperature increase or contracts as the water cools. Tanks may be open, closed or diaphragm or bladder type. See page 11 of this manual for suggested location of expansion tanks and air eliminators.
 - Open-type — located above highest radiator or baseboard unit, usually in the attic or closet. Has a gauge glass and overflow pipe to a drain.
 - Closed-type — welded gas tight and located above boiler. Tank is partially filled with water, leaving an air cushion for expansion.
 - Make sure this type of tank is fitted with a tank fitting, such as the B & G Tank-Trol or Taco Taco-Trol. This fitting reduces gravity circulation of air-saturated tank water back to the system and prevents the air from bubbling up through the water as it returns from the system.
 - Do not use automatic air vents in systems with closed-type tanks. The air will escape from the system instead of returning to the tank. Eventually, the tank will waterlog and no longer control pressurization. The boiler relief valve will weep frequently.
 - **Diaphragm- or bladder-type** — welded gas tight with a rubber membrane to separate the tank pressurizing air and the water. May be located at any point in the system, but most often found near the boiler.
 - Systems with this type of expansion tank require at least one automatic air vent, preferably located on top of an air eliminator, as shown in examples in this manual.
2. If relief valve has tended to weep frequently, the expansion tank may be waterlogged or undersized.
 - **Closed-type tank** — tank is most likely waterlogged. Install a tank fitting if not already installed. Then check fill level per fitting manufacturer's instructions. If fill level is correct, check tank size against manufacturer's instructions. Replace with a larger tank if necessary.
 - **Diaphragm- or bladder-type** — first, check tank size to be sure it is large enough for the system. If size is too small, add additional tank (or tanks) as necessary to provide sufficient expansion. If tank size is large enough, remove tank from system and check charge pressure (usually 12 psig for residential applications). If tank won't hold pressure, membrane has been damaged. Replace tank.

Inspect ignition electrode

1. Remove the ignition electrode from the boiler heat exchanger access cover.
2. Remove any white oxides accumulated on the ignition electrode using steel wool. If the ignition electrode cannot be cleaned satisfactorily, replace ignitor with a new one.
3. Reinstall ignition electrode, making sure gasket is in good condition and correctly positioned.
4. Make sure the electrodes are parallel to each other.

Check ignition wiring

1. Check ignition cable electrical resistance. A good cable will have resistance between 900 and 1000 ohms. Replace if not acceptable.
2. Inspect boiler ground wire from heat exchanger access cover to ground terminal strip.
3. Verify all wiring is in good condition and securely attached.
4. Check ground continuity of wiring using continuity meter.
5. Replace ground wires if results are not satisfactory.

Check all boiler wiring

1. Inspect all boiler wiring, making sure wires are in good condition and securely attached.

Check control settings

1. Use the U-Control display to navigate through all settings. Adjust settings if necessary.
2. Check settings of external limit controls (if any) and adjust if necessary.

Perform startup and checks

1. Start boiler and perform checks and tests specified in this manual.
2. Verify cold fill pressure is correct and that operating pressure does not go too high.
3. Complete the check-out procedure on page 42.



Annual startup *(continued)*

Check burner flame

⚠WARNING The boiler contains ceramic fiber materials. Use care when handling these materials per instructions on page 109 of this manual. Failure to comply could result in severe personal injury.

1. Inspect flame through observation window using the procedure on page 40.
2. If flame is unsatisfactory at either high fire or low fire, turn off boiler and allow boiler to cool down. Then remove burner and clean it thoroughly using a vacuum cleaner or compressed air. Do not use compressed air to clean burner if performed inside a building.
3. To access the burner, remove the heat exchanger cover plate following the procedure beginning on page 125.
4. When replacing burner, ensure gasket is in good condition and correctly positioned. After tightening the three retainer screws, bend up the retainer tabs as shown in Figure 120 to prevent screw rotation.
5. Reattach the cover plate using the method given in Figure 126, page 126 or Figure 128, page 127.
6. After servicing, reinstall boiler components. Retest boiler.

Check flame signal

1. Navigate to Diagnostics/Inputs on the U-Control display (see Figure 115, page 102). The flame signal value must be at least 20 above the Shutdown values given in Figure 119.

Figure 119 Flame signal shutdown values

Model Ultra –	Shutdown flame signal	Model Ultra –	Shutdown flame signal
80	95	230	100
80 HA	95	230 HA	100
105	135	299	130
105 HA	135	299 HA	130
155	80	399	120
155 HA	80	399 HA	120

NOTE: “HA” means high altitude, 5500 feet or more above seal level.

2. If the flame signal drops to less than 20 above the Shutdown values, the U-Control will attempt to correct by increasing the boiler firing rate to increase flame signal.
3. A lower flame signal may indicate a fouled ignitor or damaged ignitor insulation. If cleaning the ignitor does not improve, ground wiring is in good condition, and ground continuity is satisfactory, replace the ignitor.

Figure 120 Burner assembly

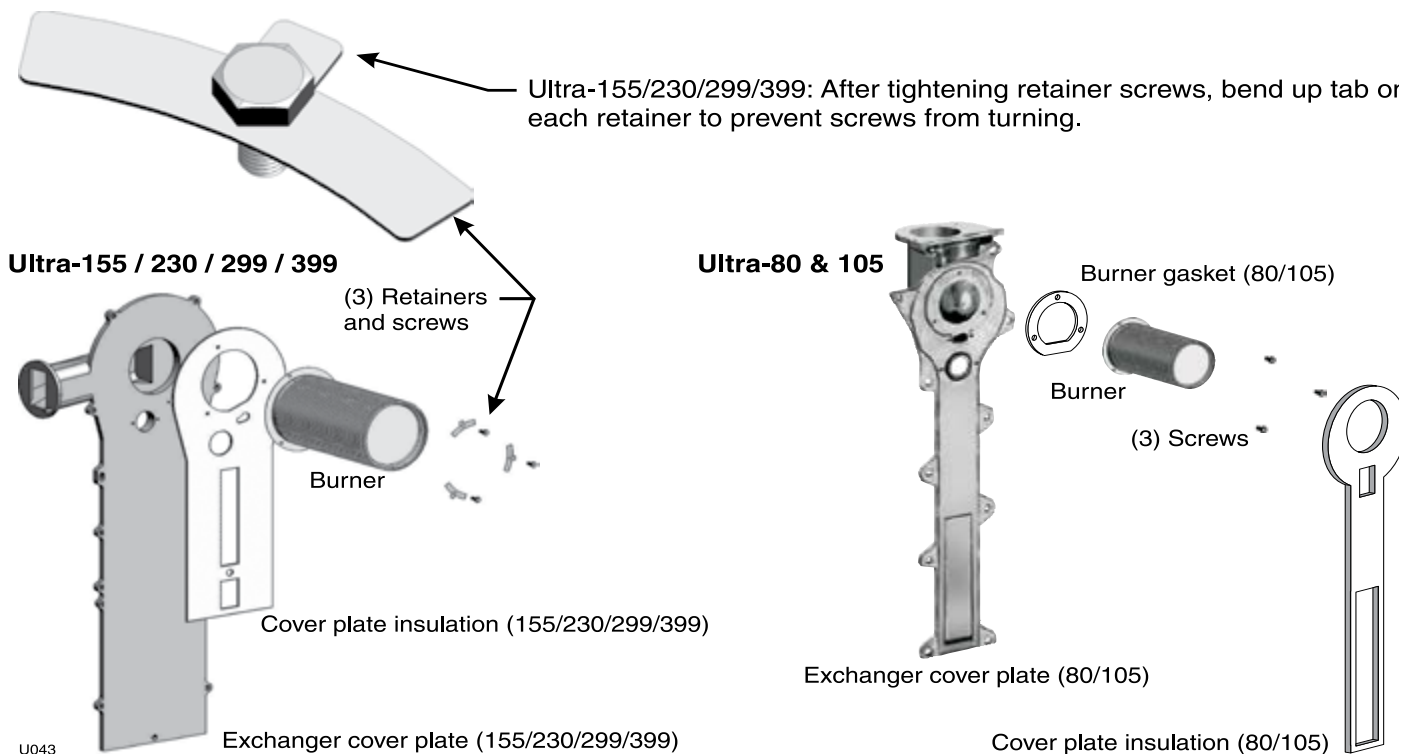



Annual startup *(continued)*

- If flame signal still remains low, inspect the vent and air piping. Then inspect the heat exchanger, following the procedures given in this manual for removal and reinstallation of the head exchanger cover plate and other boiler components. Clean the exchanger as described in this manual if necessary.

Check blower speeds

- For installations at altitudes above 5,500 feet, make sure the control is set up for high altitude in the boiler setup menu. The U-Control module automatically adjusts low fire and ignition rates to compensate for high altitude conditions.
- For installations below 5,500 feet, high altitude should NOT be enabled.
- Use the U-Control display to navigate to Manual test mode (see Figure 115, page 102).
- Set the firing rate to MINIMUM (low fire).
- Write down the blower RPM value shown and compare to the value in Figure 121. The value should no less than the “Minimum setting” and no higher than the Ignition “Factory setting” listed. Low fire rate (and corresponding blower speed) is adjusted in the boiler setup menu.
- Set the firing rate to MEDIUM (ignition rate).

- Write down the blower RPM value. It should be within 200 RPM of the value listed in Figure 121.
- Set the firing rate to MAXIMUM (high fire).
- Write down the blower RPM value. It should be within 200 RPM of the value given in Figure 121.
- If any of the values are outside the ranges listed in the previous steps, contact the factory for technical assistance.

Check flue gas temperature

- Set the boiler to high fire. Then adjust the U-Control module display to view flue gas temperature and boiler return temperature.
- The flue gas temperature should be no more than 54 °F higher than the boiler return temperature.
- If the flue temperature is higher than this, shut down the boiler, allow to cool, and follow the procedure starting on page 125 to clean the Nanogate coated heat exchanger.

Figure 121 Firing rates and corresponding blower speeds (low fire, ignition, and high fire) — for altitudes up to 5,500 feet

Ultra Model	-80			-105			-155			-230			-299			-399		
	%	RPM	Btu/Hr	%	RPM	Btu/Hr	%	RPM	Btu/Hr	%	RPM	Btu/Hr	%	RPM	Btu/Hr	%	RPM	Btu/Hr
Low fire																		
Minimum setting	20	1,300	16,000	20	1,300	21,000	20	1,300	31,000	20	1,300	46,000	20	1,400	62,000	20	1,520	79,800
Factory setting	33	1,983	26,400	33	1,983	34,650	33	1,983	51,150	33	1,983	75,900	33	2,156	102,300	20	1,520	79,800
High altitude	33	1,983	26,400	33	1,983	34,650	33	1,983	51,150	33	1,983	75,900	30	1,981	93,000	28	2,002	111,720
Ignition (“Medium” setting in manual test mode)																		
Factory setting	47	2,300	37,600	47	2,300	49,350	47	2,300	72,850	47	2,300	108,100	36	2,330	111,600	33	2,303	131,670
High altitude	62	3,500	49,600	62	3,500	65,100	62	3,500	96,100	62	3,500	142,600	51	3,202	158,100	40	2,725	159,600
High fire (adjust if desired to match maximum system load — High fire % rate = Max heat load / Boiler output)																		
Factory setting	94	5,200	75,200	94	5,200	98,700	94	5,200	145,700	94	5,200	216,200	96	5,818	297,600	96	6,099	383,040
Maximum setting	100	5,500	80,000	100	5,500	105,000	100	5,500	155,000	100	5,500	230,000	100	6,050	299,000	100	6,340	399,000

Annual startup *(continued)*

Check boiler relief valve

1. Inspect the relief valve and lift the lever to verify flow as in the following warnings, excerpted from a relief valve manufacturer's warning label. Before operating any relief valve, ensure that it is piped with its discharge in a safe area to avoid severe scald potential. Read page 9 before proceeding further.

⚠ WARNING Safety relief valves should be reinspected AT LEAST ONCE EVERY THREE YEARS, by a licensed plumbing contractor or authorized inspection agency, to ensure that the product has not been affected by corrosive water conditions and to ensure that the valve and discharge line have not been altered or tampered with illegally. Certain naturally occurring conditions may corrode the valve or its components over time, rendering the valve inoperative. Such conditions are not detectable unless the valve and its components are physically removed and inspected. This inspection must only be conducted by a plumbing contractor or authorized inspection agency — not by the owner. Failure to reinspect the boiler relief valve as directed could result in unsafe pressure buildup, which can result in severe personal injury, death or substantial property damage.

⚠ WARNING Following installation, the valve lever must be operated AT LEAST ONCE A YEAR to ensure that waterways are clear. Certain naturally occurring mineral deposits may adhere to the valve, rendering it inoperative. When manually operating the lever, water will discharge and precautions must be taken to avoid contact with hot water and to avoid water damage. Before operating lever, check to see that a discharge line is connected to this valve directing the flow of hot water from the valve to a proper place of disposal. Otherwise severe personal injury may result. If no water flows, valve is inoperative. Shut down boiler until a new relief valve has been installed.

2. After following the above warning directions, if the relief valve weeps or will not seat properly, replace the relief valve. Ensure that the reason for relief valve weeping is the valve and not over-pressurization of the system due to expansion tank waterlogging or under-sizing.

Review with owner

1. Review the User's Information Manual with the owner.
2. Emphasize the need to perform the maintenance schedule specified in the User's Information Manual (and in this manual as well).
3. Remind the owner of the need to call a licensed contractor should the boiler or system exhibit any unusual behavior.
4. Remind the owner to follow the proper shutdown procedure and to schedule an annual startup at the beginning of the next heating season.



Troubleshooting

VERIFY PROPER OPERATION AFTER SERVICING.

CAUTION Before servicing and making connections . . . **ALWAYS TURN POWER OFF TO THE BOILER TO PREVENT ELECTRICAL SURGES, WHICH CAN DAMAGE BOILER COMPONENTS.**

WARNING **ELECTRICAL SHOCK HAZARD** — The boiler ON/OFF switch does not turn off all power to the boiler. **TURN OFF ALL POWER TO THE BOILER WHEN SERVICING.** Internal wiring is still powered when the switch is off.

CAUTION Label all wires prior to disconnection when servicing controls. Wiring errors can cause improper and dangerous operation. Always disconnect power to boiler before servicing. Failure to comply could result in severe personal injury, death or substantial property damage.

WARNING Never jumper (bypass) any device except for momentary testing. Severe personal injury, death or substantial property damage can result.

NOTICE Before calling, always complete the “**Ultra Gas Data Collection Sheet**” (page 124). Record the boiler size and CP number (located on the lower center support frame in the center of the boiler).

Reinstall boiler jacket front door

WARNING Reinstall boiler jacket front door after servicing. The boiler front door must be securely fastened to the boiler to prevent boiler from drawing air from inside the boiler room. This is particularly important if the boiler is located in the same room as other appliances. Failure to keep the door securely fastened could result in severe personal injury or death.

Before troubleshooting:

1. See Figure 122 for tools and kits recommended for troubleshooting Ultra boilers.
2. Check for 120 VAC (minimum 102 VAC to maximum 132 VAC) to boiler.
3. Check the U-Control’s last three lockout histories.
 - a. See page 99, “ADVANCED SETUP – OVERVIEW.”
 - b. Scroll down to DIAGNOSTICS and press the enter key.
 - c. Scroll down to ERRORS and press the enter key.
 - d. Record the first four data records and then highlight the history record you want to view.
 - e. Follow information at the bottom of the screen to navigate through your lockout histories.

Figure 122 Tools and kits for troubleshooting

Tools needed for troubleshooting	Purpose
#2 Phillips Screwdriver	Remove 4 screws to remove the top front cover
U-Control Screwdriver or 1/16" flat blade screwdriver	Used for wiring on terminal blocks for the U-Control (comes with boiler)
1/8" Allen Wrench (Hex Key)	To add orifice to change from natural to propane
7mm Nut driver (Ultra 155/230/299/399)	To change the burner (#2 Phillips Screwdriver for the 80 and 105)
11mm Nut driver	To remove the front cover plate on the burner
4mm Allen wrench (long handled preferred)	To remove the blower assembly from the heat exchanger
Multimeter	To take measurement readings on sensors and electrical components
Manometer (Incline or digital)	To measure the gas pressure coming to the boiler.
Combustion analyzer (Digital preferred)	For combustion testing.
Contact thermometer	For checking surface temperatures of heat exchanger and pipes
P/N 383-500-605 Maintenance Kit (80 and 105)	This kit should be on hand when performing annual maintenance in the event replacement is required.
P/N 383-500-620 Maintenance Kit (155/230/299/399)	This kit should be on hand when performing annual maintenance in the event replacement is required.



Troubleshooting *(continued)*

Check the following:

1. Make sure thermostat is calling for heat and contacts (including appropriate zone controls) are closed. Check for 24 VAC between thermostat wire nuts and ground.
2. Make sure all external limit controls are either installed (and closed) or temporarily jumpered for testing.
3. Make sure that connectors to control module are securely plugged in at module and originating control.
4. Gas pressures:
 - Maximum: 13" w.c. with no flow (lockup) or with boiler on
 - Minimum: 4" w.c. (for all except 5" for -299) for natural gas, or 4" w.c. for propane, with gas flowing (verify during startup with boiler at high fire)

Always check control module fuses

⚠WARNING ALWAYS check control module fuses before replacing control module or any major components (blower, etc.). If one of these fuses is blown, it can prevent control module or other components from operating.

1. Turn OFF power to boiler at external line switch.
2. Remove jacket door and jacket top panel. Rotate the swing-away control panel forward to expose the U-Control module.
3. Remove and inspect the two fuses (located as shown below).

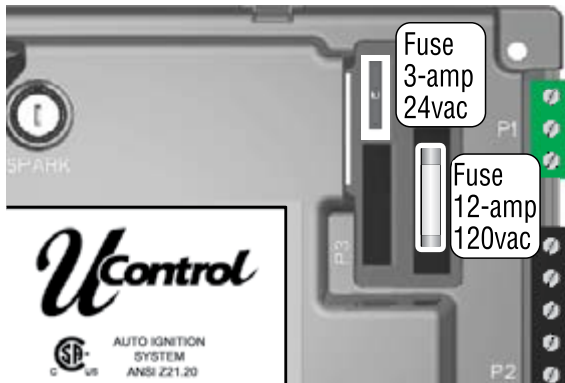

4. If necessary, replace the fuse:
 - a. Low voltage circuit fuse is 3-amp fast-blow (Littelfuse 257003).
 - b. Line voltage circuit fuse is 12-amp slow-blow (Littelfuse 326012P).

⚠WARNING Do not jumper fuse or replace with any fuse except as specified. Failure to comply could result in severe personal injury, death or substantial property damage.

5. Reinstall jacket top panel and boiler jacket door after checking the fuses.
6. Restore power to boiler at external line switch and verify boiler operation after completing boiler service.

Checking temperature sensors

1. The boiler temperature sensors (flue, outdoor, return water and supply water) are all resistance-type devices.
2. Figure 123 shows the correct value for the sensor at various temperatures.
3. Use the resistance values at 32°F, 60°F, 70°F and 212°F to measure the sensor resistance at known temperatures (ice point, room temperature and sea level boiling point). For ice point and boiling point, insert the sensor in water at that temperature. Use an ohmmeter to read resistance value.
4. To check whether the control module is correctly sensing temperature, you can use a resistance decade box. Connect the decade box temporarily in place of a sensor and read the corresponding temperature on the U-Control display. The temperature should be close to the value corresponding to the input resistance.

Figure 123 Sensor resistance values

Sensor resistance values					
Temp (°F)	Sensor ohms		Temp (°F)	Sensor ohms	
	Min	Max		Min	Max
32	34265	37871	120	4517	4992
40	27834	30764	130	3698	4088
50	21630	23907	140	3043	3364
60	16944	18727	150	2517	2782
70	13372	14780	160	2091	2311
80	10629	11747	170	1744	1928
90	8504	9399	180	1461	1615
100	6847	7568	190	1229	1359
110	5545	6129	200	1038	1147



Troubleshooting *(continued)*

WARNING Make sure to determine the causes of outages. Do not leave the boiler operating without a complete diagnosis.

U-Control fault indications

1. The U-Control provides diagnostic information for both automatic reset conditions and manual reset conditions. See Figure 117, page 106 for information available on the U-Control display.
2. Figure 124 shows the screen behavior during an automatic or manual reset condition. The table below the display illustration lists manual reset conditions and how to reset from them.
3. Figure 125, page 118 lists conditions that will cause the control to display a constant red screen. The boiler will automatically restart if the condition self-corrects or the technician uses the U-Control's manual reset screens to reset.

Figure 124 U-Control display toggles when in lockout, with screen flashing red to gray

NOTICE: Screen background color alternates from RED to no backlight (gray screen).

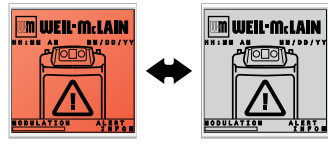

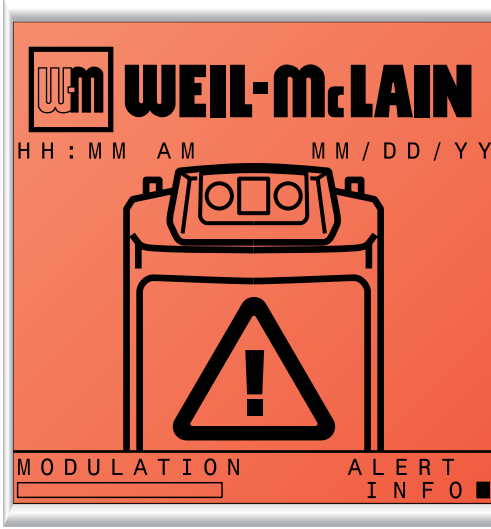

SEE TOP LINE OF DISPLAY FOR ERROR

↓

MAINTENANCE

NAME : #####

PHONE : ### - ### - ####

MODEL : ULTRA #####

CP# : #####

INSTALLED : DD/MM/YY

LAST DATE : DD/MM/YY

NEXT DATE : DD/MM/YY

INTERVAL SETTINGS

RESET REMINDER

◀ PREVIOUS ENTER ■

3

ALTERNATING
SCREENS

Select **MANUAL RESET** to reset condition. Make sure to correct the cause of the problem if possible.

The service technician can change the interval setting by selecting this line.

Select **RESET REMINDER** to reset the counter. The reset reminder will not occur again until the INTERVAL time has elapsed.

—Alternating Date/Time & Error Info Here—

STATUS : #####

MODULATION :

TARGET : ### ° F

SUPPLY : ### ° F

RETURN : ### ° F

OUTDOOR : ### ° F

DEMAND : ### ### ###

PUMPS : # # #

ADD'L HEAT DEMAND : ###

SETTINGS

MANUAL RESET

SELECT ▲▼

◀ PREVIOUS ENTER ■



Troubleshooting *(continued)*

Figure 125 Troubleshooting suggestions for Ultra boilers

U-Control Error Condition Log

The U-control is able to record information about the boiler’s condition at the time of the three previous faults or errors. This information is available to view in Contractor Menus under “DIAGNOSTICS” by selecting “ERRORS.” The control will display the following information:

Information	Description	Action
Control Fault	Records the number of internal control faults	Select and press the enter key to reset this count
Ignition Retries	Displays the number of ignition attempts in the current ignition sequence.	
Manual Reset Count	Records number of lockouts that required a manual reset since this count was last cleared.	Select and press the enter key to reset this count
Auto Reset Count	Records number of lockouts that have automatically reset since this count was last cleared.	Select and press the enter key to reset this count
Lockout History 1	Details of present or last recorded lockout	Select and press the enter key for more details
Lockout History 2	Details of boiler during the second oldest lockout still in memory	Select and press the enter key for more details
Lockout History 3	Details of boiler during the oldest lockout still in memory	Select and press the enter key for more details

How to read the last 3 lockout histories:

1. Scroll down to “DIAGNOSTICS” and press the enter key (Square Key in center)
2. Scroll down to “ERRORS” and press the enter key (Square Key in center)
3. Scroll down to “LOCKOUT HISTORY #” and press the enter key.
4. Scroll to choose the either “MANUAL RESET” or “AUTO RESET” and press the enter key to display the fault condition that was recorded.
5. Press the left arrow key to return to the LOCKOUT HISTORY # screen. Scroll up or down to highlight other choices and press the enter key to view the details of the boiler’s condition when the lockout was recorded.
6. TO CLEAR ALL LOCKOUT HISTORIES: While on the “ERRORS” screen, hold the Left and Right arrow buttons simultaneously for 5 seconds.

U-Control Fault Displays, Diagnostics and Suggested Corrective Actions

Display	Condition	Diagnostics	Corrective Action(s)
Nothing shown on display screen and blower running at full speed	Control is not receiving 24V power	Check wiring for short circuit or incorrect wiring.	Correct wiring per wiring diagram including connection of transformer to the U-Control.
		Check 3-amp low voltage fuse on U-Control shown on page 100.	Replace fuse with proper part found in replacement part section of this manual. If fuse blows again recheck wiring per diagram.
		Check transformer connection to the U-control per wiring diagram. Check for 24V output of transformer.	Replace transformer if it is receiving 120VAC, but not outputting 24VAC.



Troubleshooting *(continued)*

Figure 125 Troubleshooting suggestions for Ultra boilers *(continued)*

Display	Condition	Diagnostics	Corrective Action(s)
Nothing is shown in display screen and no other boiler components are operating	Control is not receiving 120V power.	Check service switch and/or circuit breaker to boiler turned is on.	Turn on service switch to power boiler.
		Is there 120 Volts at the service switch?	Troubleshoot and correct the power supply to the service switch.
		Is the Ultra's ON/OFF POWER SWITCH located behind the control pod turned on?	Turn the Ultra's power switch behind the control pod to ON.
		Check for 120 volts at the line voltage terminal block located inside the control pod.	Correct wiring inside the control pod using the wiring diagram in this manual.
		Inspect 12-amp fuse as shown on page 100. Replace if necessary.	Replace the fuse with proper part found in the replacement part section of this manual. If fuse blows again recheck wiring per diagram.
Nothing is shown on display screen, but boiler is operating	Occurs when the communication is lost from the U-control to the display.	Check for loose connections and proper pin alignment/engagement on the U-Control's plug P9 and the back of the display circuit board.	Check for continuity on the wire harness from the display to the U-control. See repair parts section for proper replacement part.
		Cycle power off and on using boiler power switch and check for operation.	Replace with new display module. See repair parts section for proper replacement part.
TEMP RISE TOO QUICKLY	Occurs when supply water temperature in heat exchanger rises faster than 2°F per second during the first two minutes the burner is on.	Automatically resets after 1 minute delay or using manual reset on display.	Verify water pipe is installed correctly using primary/secondary connection to the boiler loop. Refer to Figure 4 page 11 for example of primary/secondary connection.
		Manual reset is necessary after 5 automatic resets have occurred during the same Priority heat demand. Reset using manual reset screen on display.	Minimum pipe sizes Ultra 80/105 - minimum 1 inch Ultra 155/230 - minimum 1.25 inch Ultra 299/399 - minimum 1.5 inch
			Verify proper circulator sizing for boiler size and system requirements starting on page 9. Boiler ship with proper size circulators: Ultra 80/105 - Taco 007e ECM or 007 Ultra 155/230/299 - Taco 0014 Ultra 399 - Taco 0013
		See message displayed TEMPERATURE SENSOR and follow procedure for loose connections.	
SUPPLY 58F > RETURN	Boiler Out temperature has exceeded the Boiler In temperature by more than 58°F, when burner is on.	Automatically resets after 30 second delay or using manual reset on display.	Verify water pipe is installed correctly using primary/secondary connection to the boiler loop. Refer to Figure 4 page 11 for example of primary/secondary connection.
			Minimum pipe sizes Ultra 80/105 - minimum 1 inch Ultra 155/230 - minimum 1.25 inch Ultra 299/399 - minimum 1.5 inch
			Verify proper circulator sizing for boiler size and system requirements starting on page 9. Boiler ship with proper size circulators: Ultra 80/105 -Taco 007e ECM Ultra 155/230/299 - Taco 0014 Ultra 399 - Taco 0013
			See message displayed TEMPERATURE SENSOR and follow procedure for loose connections.



Troubleshooting *(continued)*

Figure 125 Troubleshooting suggestions for Ultra boilers *(continued)*

Display	Condition	Diagnostics	Corrective Action(s)
RETURN > SUPPLY	<p>Occurs when a return water temperature is greater than the corresponding supply temperature by 10°F or more.</p> <p>Applies to system sensors or boiler sensors.</p> <p>Condition must occur for 10 minutes for system sensors.</p>	Automatically resets when condition no longer exists.	<p>Verify proper flow direction of the boiler circulator. This circulator should be installed to push water through the boiler's return pipe as shown in Figure 4 on page 11.</p> <p>Verify proper placement of system sensors for single or multiple boiler systems. System sensors should be on system piping not on the boiler loop.</p> <p>System sensors may need located further away from boiler loop connection to the system if proximity to the boiler loop is causing sensors to be heated inaccurately.</p>
TEMPERATURE SENSOR	Occurs when a temperature sensor has electrically shorted (SHORT) or has become disconnected (OPEN).	Automatically resets when condition no longer exists.	<p>Check all the temperature readings of the boiler on the DIAGNOSTICS - TEMPERATURES menu to determine if any sensors are currently displayed as SHORT or OPEN. Compare this to the boiler temperatures recorded in the DIAGNOSTICS - ERRORS - LOCKOUT HISTORY # - TEMPERATURES during the last several lockout conditions.</p> <p>Determine which sensors are suspect and measure their resistance value and compare it to the values shown in Figure 109. If the resistance values are incorrect replace the temperature sensor. Refer to repair parts section for proper part number.</p> <p>OUTDOOR TEMP, SYSTEM SUPPLY, and SYSTEM RETURN are the optional outdoor air temperature and system water temperature sensors. If these are not being used they will always be shown as OPEN. This is normal unless the sensors were installed.</p> <p>Check wire harness for loose connections and pin engagement at sensor connection, chassis mount connection through sheet metal cabinet, and U-Control module. Unplug connection at sensor and at U-Control and check continuity between ends.</p> <p>If problem persists after checking items above replace U-Control. Refer to repair parts section for kit number.</p>
FLUE TEMP TOO HIGH	Occurs when flue temperature sensor exceeds 216°F.	<p>Automatic reset occurs if temperature drops below 216°F for 2.5 min.</p> <p>Manual reset is required if the temperature rises above 225°F. Reset using manual reset screen on display.</p>	<p>Follow procedure for above for SHORT and OPEN sensor conditions to properly diagnose sensor. In addition inspect heat exchanger combustion chamber and flueways for abnormal wear or buildup.</p> <p>Inspect vent system for abnormal wear or damage.</p> <p>Contact Weil-McLain Technical Support.</p>
TEMPERATURE SENSOR	Occurs when dual temperature sensors values have spread by more than 10°F.	Automatically resets when sensors are within 10°F.	Follow procedure for above for SHORT and OPEN sensor conditions to properly diagnose sensor. If measured resistance values of sensors convert to temperatures separated by more than 10°F replace the sensor.
LOW WTR CUTOFF OPEN	Occurs when Low Water Cutoff Device contacts open for more than 1 second.	Requires manual reset of U-Control and may require manual reset of LWCO device depending on model.	<p>Check for low water condition in system. Repair system as necessary refer to piping section of this manual.</p> <p>If low water condition does not exist check Diagnostics - Inputs screen to view status of Low Water Cutoff. If shown as OPEN check wiring between LWCO and U-Control.</p>



Troubleshooting *(continued)*

Figure 125 Troubleshooting suggestions for Ultra boilers *(continued)*

Display	Condition	Diagnostics	Corrective Action(s)
DISPLAY COMM	Occurs when display communications out for 30 seconds.	Automatically resets when communication is re-established.	Check for a loose connection at the molex plug on the control and connection on the back of the display.
LIMIT OPEN	Occurs when manual or automatic reset limit opens.	Automatic external limit will reset 2.5 minutes after external limit device closes.	Is there an external safety device connected? If yes, trouble shoot the external limit to determine and correct the cause that opened the limit. Also check for loose wiring connections.
		Manual limit fault must be reset by choosing Reset Lockout on the display.	Remove the top front cover and inspect the ORANGE - 4 PIN connector P13. Ensure a jumper is installed between pins 1 & 2 if not using a manual reset external limit. Ensure a jumper is installed between pins 3 & 4 if not using a automatic reset external limit.
HIGH TEMP LIMIT	Boiler temperature sensor reached High Temp Limit setting (no higher than 200°F).	Reset using manual reset screen on display.	Verify all isolation valves are open and circulators are programmed into the U-Control properly. Each Priority input can be configured to turn on any combination of three circulator outputs. Refer to the U-Control Setup section to configure these properly for the system.
			Verify water pipe is installed correctly using primary/secondary connection to the boiler loop. Refer to Figure 4 page 11 for example of primary/secondary connection. Minimum pipe sizes Ultra 80/105 - minimum 1 inch Ultra 155/230 - minimum 1.25 inch Ultra 299/399 - minimum 1.5 inch
			Verify proper circulator sizing for boiler size and system requirements starting on page 9. Boiler ship with proper size circulators: Ultra 80/105 - Taco 007e ECM or 007 Ultra 155/230/299 - Taco 0014 Ultra 399 - Taco 0013
			See message displayed TEMPERATURE SENSOR and follow procedure for loose connections.
FLAME FAULT	Occurs when flame is detected when there should be no flame.	Reset using manual reset screen on display.	Burner may be operating too hot due to incorrect combustion. Inspect flame and conduct combustion test. Force boiler into hi-fire. Check flue gases with combustion analyzer and correct using the maintenance and startup procedure in this manual.
			Verify FLAME SIGNAL value quickly goes to zero on the DIAGNOSTICS - INPUTS screen when the gas valve closes.
			Check for flame at burner via flame current with burner off. Turn boiler off and watch flame through observation port. If flame continues after shutdown replace gas valve and venturi.



Troubleshooting *(continued)*

Figure 125 Troubleshooting suggestions for Ultra boilers *(continued)*

Display	Condition	Diagnostics	Corrective Action(s)
BLOWER FAULT	Blower unable to reach required speed or does not reach 0 RPM when turned off.	Automatically resets after 1 hour or can be reset by using manual reset on screen.	Check wire harness for loose connections and pin engagement at blower connections, chassis mount connection through sheet metal cabinet, and U-Control module. Unplug connection at sensor and at U-Control and check continuity between ends. Blower is connected to both low voltage and line voltage harness.
			Check Diagnostics - Inputs screen with boiler in standby mode and blower not running. If BLOWER SPEED is not 0 RPM then replace blower.
			If blower does not rotate during ignition sequence check for 120V power at blower connection. If 120Vac power at blower motor and it doesn't start replace blower. Check power at U-Control. If 120Vac is not present at U-Control when boiler is powered replace U-Control. Refer to repair parts section.
IGNITION FAULT	Boiler went through 5 ignition attempts and never detected flame.	Automatically resets after 1 hour or can be reset by using manual reset on screen.	Check condensate trap for blockage allowing condensate to accumulate inside heat exchanger
			Fouled, worn, bent, or faulty igniter. Fouled igniters can be cleaned for additional use with fine grit sand paper or steel wool. Worn or badly fouled igniters should be replaced with the proper repair part. Igniter rods should be parallel with a 3.5mm (0.138 in) spark gap.
			Dirty burner and/or heat exchanger will cause high back pressure and poor ignition. Follow procedure in maintenance section of this manual to clean burner and heat exchanger using flue cleaning tool and rinse method.
			Visual inspection of flueways will often will not be able to diagnose condition.
			Check combustion settings on high and low fire and adjust per setup instructions if necessary.
			Check incoming gas pressure with boiler off and at high fire. Adjust within limits on rating label.
			Verify correct boiler model is selected in control and high altitude is selected for installations 5500 ft above sea level.
			Check ignition cable resistance. Should measure 1000 Ohms (+/- 50 Ohms)
			Check for flue pipe and intake pipe restrictions or blockage
			Check burner fasteners and gaskets
Check venturi gaskets and proper propane orifice			
Check condensate trap for blockage allowing condensate to accumulate inside heat exchanger			



Troubleshooting *(continued)*

Figure 125 Troubleshooting suggestions for Ultra boilers *(continued)*

Display	Condition	Diagnostics	Corrective Action(s)
GAS VALVE FAULT	The U-Control has detected a problem with its gas valve output circuit	Automatic retry when condition exists. Boiler will reset if conditions clear. If condition does not clear boiler will retry in 1 hour. If condition is not clear after 1 hour, boiler will require manual reset.	Check wire harness connections between gas valve and U-Control.
			Check resistance between
			If lockout reoccurs replace U-Control.
AIR PRESSURE SW FAULT	Air Pressure switch is open	Ultra residential boilers do not use an air pressure switch, but instead have a wire jumper installed between P7 pins 4 & 5.	Check boiler size selected in U-Control against boiler rating label. Correct if necessary to select the proper boiler size.
		Reset using manual reset screen on display	Check the P7 connection as seen on Figures 98 & 99 to determine proper jumper wire location.
GAS PRESSURE SW FAULT	Gas pressure switch is open (high or low)	Residential Ultra Boilers do not use gas pressure switches. Requires manual reset.	Check boiler size selected in U-Control against boiler rating label. Correct if necessary to select the proper boiler size.
HW FAULT EXPANSION BRD	Expansion Control Board hardware has failed.	Residential Ultra Boilers do not use an Expansion Control Board. Requires manual reset.	Check boiler size selected in U-Control against boiler rating label. Correct if necessary to select the proper boiler size.
GV FAULT EXPANSION BRD	Gas valve output of the Expansion Board	Residential Ultra Boilers do not use an Expansion Control Board. Requires manual reset.	Check boiler size selected in U-Control against boiler rating label. Correct if necessary to select the proper boiler size.
EXP BOARD COM FAULT	Communication between the Expansion Control Board and the U-Control Board has failed	Residential Ultra Boilers do not use an Expansion Control Board. Requires manual reset.	Check boiler size selected in U-Control against boiler rating label. Correct if necessary to select the proper boiler size.



Ultra Gas Boiler Data Collection Sheet

Customer Info:		Maintenance Info:	
Contact:		Name:	
Contractor:		Phone:	
Job name:		Model:	
City, state:		CP#:	
Distributor:		Installed:	

System Components:	
Near boiler pipe size:	
Boiler circulator model:	
DHW tank (yes/no):	
DHW direct/system:	
Dhw model:	
Dhw pipe size:	
DHW circulator model:	
Is there air in system?:	

Boiler/System Piping Details (Please Sketch)
Please note the placement of system sensors

Diagnostic Errors:	
Control fault:	
Ignition retries:	
Manual reset CNT:	
Auto reset CNT:	

Software Versions:	
Display:	
Main micro:	
Second micro:	

Lockout History	#1
HH:MM MM/DD/YY:	
Status:	
Manual reset:	
If yes-description:	
Auto reset:	
If yes-description:	
Priority 1:	
Priority 2:	
Priority 3:	
Manual limit:	
Auto limit:	
Low WTR Cutoff:	
Blower tach:	
Flame Signal:	
Outputs:	
Gas valve:	
Circulator 1:	
Circulator 2:	
Circulator 3:	
Blower signal:	
Additional heat demand:	
Alarm:	
Temperatures:	
System supply:	
System return:	
Boiler out 1:	
Boiler out 2:	
Boiler in 1:	
Flue 1:	
Flue 2:	
Outdoor:	

Lockout History	#2
HH:MM MM/DD/YY:	
Status:	
Manual reset:	
If yes-description:	
Auto reset:	
If yes-description:	
Priority 1:	
Priority 2:	
Priority 3:	
Manual limit:	
Auto limit:	
Low WTR Cutoff:	
Blower tach:	
Flame Signal:	
Outputs:	
Gas valve:	
Circulator 1:	
Circulator 2:	
Circulator 3:	
Blower signal:	
Additional heat demand:	
Alarm:	
Temperatures:	
System supply:	
System return:	
Boiler out 1:	
Boiler out 2:	
Boiler in 1:	
Flue 1:	
Flue 2:	
Outdoor:	

Lockout History	#3
HH:MM MM/DD/YY:	
Status:	
Manual reset:	
If yes-description:	
Auto reset:	
If yes-description:	
Priority 1:	
Priority 2:	
Priority 3:	
Manual limit:	
Auto limit:	
Low WTR Cutoff:	
Blower tach:	
Flame Signal:	
Outputs:	
Gas valve:	
Circulator 1:	
Circulator 2:	
Circulator 3:	
Blower signal:	
Additional heat demand:	
Alarm:	
Temperatures:	
System supply:	
System return:	
Boiler out 1:	
Boiler out 2:	
Boiler in 1:	
Flue 1:	
Flue 2:	
Outdoor:	



Maintenance

Disconnect power

▲WARNING Electrical shock hazard — Disconnect all electrical power to the boiler before attempting maintenance procedures. Failure to complete could result in severe personal injury, death or substantial property damage.

Install boiler jacket front door after startup or servicing

▲WARNING Reinstall boiler jacket front door after start-up or servicing. The boiler front door must be securely fastened to the boiler to prevent boiler from drawing air from inside the boiler room. This is particularly important if the boiler is located in the same room as other appliances.

Inspect boiler jacket door gaskets. Gaskets must be in good condition, with no tears or gaps. Replace if necessary.

Failure to keep the door securely sealed and fastened could result in severe personal injury or death.

Perform start-up and check/out

▲WARNING Removing and reinstalling components can change boiler behavior. After any maintenance procedure, you must prove the boiler is operating correctly. To do so, follow the complete procedure for boiler and system start-up, beginning on page 35. Failure to comply could result in severe personal injury, death or substantial property damage.

General maintenance

1. Oil motor in system requiring regular oiling.
2. See Oiled bearing circulators for motor oiling procedures.

Oiled bearing circulators

1. The circulator shipped with the Ultra boiler is water-lubricated. No oiling is required.
2. Check other circulators in the system. Oil any circulators requiring oil, following circulator manufacturer's instructions. Over-oiling will damage the circulator.

NOTICE Attention to homeowners and installers of Ultra Series 4 boilers— see page 126 for the latest cleaning information for our newly coated heat exchangers.

Cleaning the heat exchanger — pin side when required

▲WARNING The boiler contains ceramic fiber materials. Use care when handling these materials per instructions on page 109 of this manual. Failure to comply could result in severe personal injury.

1. Shut down boiler:
 - a. Follow “To Turn Off Gas to Appliance” instructions on boiler and Lighting instructions.
 - b. Do not drain boiler unless it will be exposed to freezing temperatures. If using freeze prevention fluid in system, do not drain.
2. Allow time for boiler to cool to room temperature if it has been firing.
3. Remove jacket front door by removing two (2) screws at lower front. Lift door away from boiler to remove.
4. Follow the applicable procedures under “Accessing & cleaning heat exchanger: Ultra-80 and Ultra-105 Only,” page 126 or “Accessing & cleaning exchanger: Ultra-155, -230, -299 and -399 Only,” page 127.

Clean the cast aluminum heat exchanger when required — water side

1. In order for the efficiency of boilers to increase beyond the condensing limit, new materials have been introduced for the heat exchanger, including aluminum.
2. Aluminum has excellent heat transfer characteristics and is light in weight.
3. These new materials also require cleaning solutions that differ from those used in conventional cast iron and steel boilers.

▲WARNING One common cleaning method that **CANNOT** be used with systems containing aluminum is a solution of trisodium phosphate, commonly referred to as “TSP.”

The reason that trisodium phosphate cannot be used is that the cleaning solution has a very high pH level — while removing the scale in the system, it also removes the natural protective oxide layer from the aluminum. The oxide layer will reform, but if small amounts of the trisodium phosphate remain in the system, the chemical will continue to remove the protective oxide layer, leading to reduced heat exchanger life.

4. Use **ONLY** the cleaning product available from Weil-McLain, Sentinel X400. See the Repair Parts section at the end of this manual for ordering information.



Maintenance *(continued)*

*For the first 5 years, vacuum or rinse heat exchanger with water only.
No tool cleaning is necessary.*

- This heat exchanger is coated to prevent the formation of Aluminum Oxide. Cleaning the heat exchanger via mechanical means (cleaning tools, blade, or brush) could shorten the life of the coating.
- Heat exchanger inspection is recommended at yearly intervals. Only clean heat exchanger if soiling is clearly present. If cleaning is necessary flush only with water and a mild detergent. From the cover plate opening, inspect the collection area and underneath the vent pipe to ensure that it is free of debris. If cleaning is necessary flush only with water and a mild detergent.
- Cleaning the heat exchanger should not be necessary until 5 years after commissioning date.

Accessing & cleaning heat exchanger: Ultra-80 and Ultra-105 Only

1. Close the external manual gas valve.
2. Disconnect the flexible gas line at its flare fitting.
3. Remove the air silencer by separating it from the air adapter on the blower inlet.
4. Disconnect wiring: • gas valve plug • blower power supply plug • blower control connector • ignition cable • ground wire.
5. Release the heat exchanger cover plate by removing the nuts securing it to the exchanger.
6. Pull the entire blower/venturi/gas valve/cover plate assembly out of the boiler. (See Replacement parts section for component identification and locations.)
7. Use a vacuum cleaner to remove any accumulation on the heating surfaces. Do not use any solvent.
8. If the vacuum cleaner is unable to clean completely, wash the heating surfaces with clean, warm water. If further cleaning is necessary, use the Heat Exchanger Cleaning Tool (see Replacement parts at the end of this manual) or a piece of 20-gauge or lighter sheet metal 3/4" wide by about 18 inches long to loosen deposits. See Figure 127. **See water spraying notice on next page.**
9. Inspect the heat exchanger cover plate insulation. Replace if insulation is damaged. Read the ceramic fiber WARNING on page 109 before handling or disposing of ceramic fiber materials.
10. Reinstall the blower/venturi/gas valve/cover plate assembly and secure the cover plate with nuts.

WARNING You must gradually tighten the cover plate nuts. For Ultra-80 and -105, follow the tightening sequence shown in Figure 126, making two or three passes with a torque wrench. The final torque MUST NOT exceed 50 inch-pounds, +/- 10 inch-pounds.

11. Reconnect wiring: • gas valve plug • blower power supply plug • blower control connector • ignition cable • ground wire.

DANGER If the valve adapter block is removed, carefully inspect the O-ring that should still be in the gas valve inlet adapter block. The O-ring must be in good condition and must be installed when gas valve is reconnected. Failure to comply will cause a gas leak, resulting in severe personal injury or death.

12. Reconnect the flexible gas line.
13. Reinstall the air silencer by pressing onto the air inlet adapter.
14. Perform a soap suds leak test on all interior gas piping after starting the boiler.

Cleaning the heat exchanger — water side (ALL models)

1. Follow the procedure given in "Clean the cast aluminum heat exchanger when required — water side," page 125 to clean the water side of the exchanger.
2. Follow the complete procedure for boiler and system start-up, beginning on page 35.

Figure 126 Nut tightening sequence — 80 & 105
Gradually tighten the nuts, repeating the sequence shown below until the torque reaches 50 inch-pounds (+/- 10 inch-pounds)

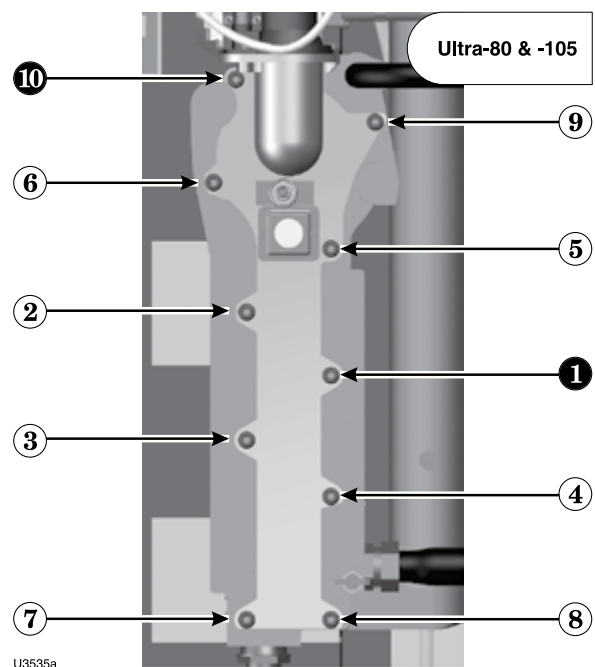
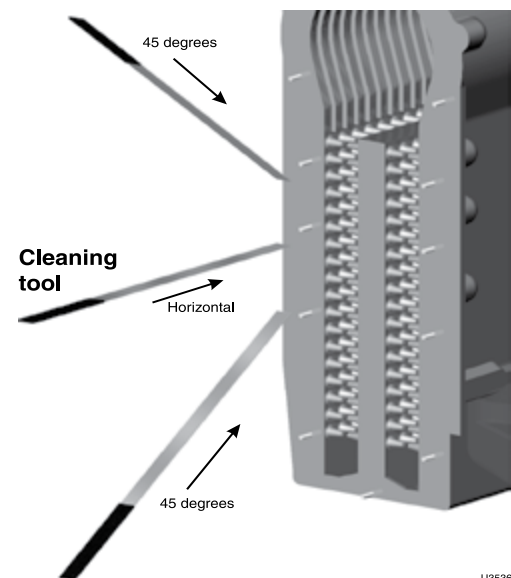

Figure 127 Cleaning the exchanger pin-side



Maintenance *(continued)*

Accessing & cleaning exchanger: Ultra-155, -230, -299 and -399 Only

1. Close the external manual gas valve.
 2. Disconnect wiring: • gas valve electrical plug • two electrical Molex plugs from the blower assembly • ignition cable • ground wire.
 3. Disconnect the flexible gas line at its flare fitting.
 4. Remove the air silencer by lifting the plastic clamp off of the gas line and then gently sliding the air silencer down and off the valve.
 5. Remove hex head nuts (10mm box end wrench) from heat exchanger cover plate and remove burner cover plate from heat exchanger.
 6. Pull the entire blower/venturi/gas valve/cover plate assembly out of the boiler. (See Replacement parts section for component identification and locations.)
 7. Remove three (3) M4 hex head screws (7mm box end wrench) and burner clips securing burner to cover plate. Remove cover plate.
 8. Use a vacuum cleaner to remove any accumulation on the heating surfaces. Do not use any solvent.
 9. If the vacuum cleaner is unable to clean completely, wash the heating surfaces with clean, warm water. If further cleaning is necessary, use the Heat Exchanger Cleaning Tool (see Replacement parts at the end of this manual) or a piece of 20-gauge or lighter sheet metal $\frac{3}{4}$ " wide by about 18 inches long to loosen deposits. See Figure 127, page 126. **See water spraying notice.**
 10. Inspect the heat exchanger cover plate insulation and gasket. Replace if damaged. Read the ceramic fiber WARNING on page 109 before handling or disposing of ceramic fiber materials.
 11. Replace the burner, hex head screws and burner clips removed in step 7. See Figure 120, page 112.
 12. Place cover plate gasket in groove of heat exchanger cover plate. Replace cover plate.
 13. Reinstall hex head nuts on the cover plate mounting studs and tighten in a staggering pattern until cover plate is uniformly tightened.
- ⚠ WARNING** You must gradually tighten the cover plate nuts. For Ultra-155 through -399, follow the tightening sequence shown in Figure 128, making two or three passes with a torque wrench. The final torque MUST NOT exceed 50 inch-pounds, +/- 10 inch-pounds.
14. Reinstall air silencer by sliding on gas valve venturi and securing clamp to gas line.
 15. Reconnect wiring: • gas valve electrical plug • two electrical Molex plugs from the blower assembly • ignition cable • ground wire.
 16. Reconnect the flexible gas line and gas valve electrical plug.
 17. Perform a soap suds leak test on all interior gas piping after starting the boiler.

Cleaning the heat exchanger — water side (ALL models)

1. Follow the procedure given in “Clean the cast aluminum heat exchanger when required — water side,” page 125 to clean the water side of the exchanger.
2. Follow the complete procedure for boiler and system start-up, beginning on page 35.

Figure 128 Nut tightening sequence — 155 to 399 — Gradually tighten the nuts, repeating the sequence shown below until the torque reaches 50 inch-pounds (+/- 10 inch-pounds)

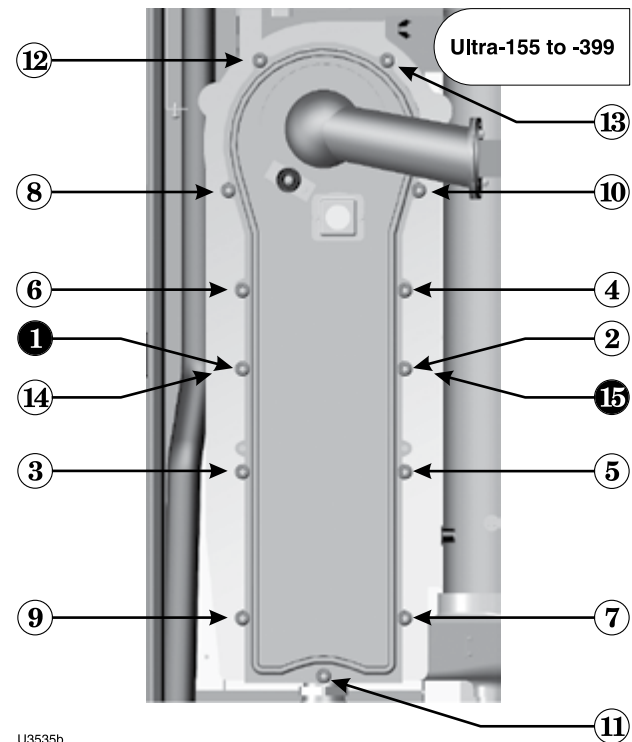

WATER SPRAY HEAT EXCHANGER PINS AFTER USING CLEANING TOOL

1. After using the cleaning tool as shown in Figure 127, page 126, spray water downward from above the pins to flush remaining sediment.
2. Remove sediment from the bottom of the heat exchanger.
3. Then disconnect the condensate line at the bottom of the heat exchanger.
 - a. Loosen the hose clamps at both ends of the condensate line.
 - b. Remove the line and place a pan under the trap connection.
 - c. Spray water into the bottom of the heat exchanger to flush remaining sediment to the condensate outlet.
 - d. Spray water through the condensate line to clean it thoroughly.
 - e. Remove pan and replace the condensate line.
 - f. Follow instructions on page 126 or page 127 to check components and replace burner and cover.



Replacement parts

⚠️ WARNING Replacement parts must be purchased through a local Weil-McLain distributor. When ordering, specify boiler model and size and include description and part number of replacement part. Results from using modified or other manufactured parts will not be covered by warranty and may damage boiler or impair operation.

NOTICE Weil-McLain part numbers are found in Weil-McLain Boilers and Controls Repair Parts Lists.



⚠️ WARNING **The boiler contains ceramic fiber materials.** Use care when handling these materials per instructions on page 109 of this manual. Failure to comply could result in severe personal injury.

Reinstall boiler jacket front door after startup or servicing

⚠️ WARNING Inspect boiler jacket front door gaskets and reinstall boiler jacket front door after start or servicing. The boiler front door must be securely fastened to the boiler to prevent boiler from drawing air from inside the boiler room. This is particularly important if the boiler is located in the same room as other appliances. Failure to keep the door securely fastened could result in severe personal injury or death.

Figure 129 Propane conversion kits and instructions

⚠️ WARNING The conversion kits listed below are only for use with Ultra Series 4 boilers. For series 1 or series 2 boilers, refer to the boiler manual or contact Weil-McLain for the correct parts.

Natural to propane conversion — SERIES 4 BOILERS ONLY <i>(not required for Ultra-399 — adjustment is made with throttle screw, not with orifice)</i>							
Sea level (to 5,500 feet altitude)				High altitude (above 5,500 feet)			
Model	Kit part #	Kit location	Instructions	Model	Kit part #	Kit location	Instructions
Ultra-80	383-501-020	SPECIAL ORDER	 In kit only	Ultra-80LP	383-500-644	SPECIAL ORDER	See page 48 or kit
Ultra-105	540-100-001 Supplied with boiler		See page 48	Ultra-105	383-500-645	SPECIAL ORDER	See page 48 or kit
Ultra-155	383-500-115 Supplied with boiler		See page 49	Ultra-155	383-500-646	SPECIAL ORDER	See page 49 or kit
Ultra-230	383-500-120 Supplied with boiler		See page 49	Ultra-230	383-500-647	SPECIAL ORDER	See page 49 or kit
Ultra-299	540-202-832 Supplied with boiler		See page 49	Ultra-299	383-500-394	SPECIAL ORDER	See page 49 or kit
Propane to natural conversion							
-80	383-501-021	SPECIAL ORDER	 In kit only	Contact factory			

⚠️ Boilers marked with this symbol require special installation procedures. Do not use the instructions in this manual — use only the instructions supplied in the conversion kit.



Replacement parts *(continued)*

Figure 130 Miscellaneous parts and kits

Description	Part Number												
CHEMICALS													
Antifreeze, aluminum-safe, Sentinel X500 (1 gallon)	592-900-029												
Antifreeze, aluminum-safe, Sentinel X500 (5 gallon)	592-900-006												
Corrosion inhibitor, Sentinel X100 (one tube, 275 ml)	592-900-002												
Inhibitor quick-test kit	592-900-005												
Cleaner, Sentinel X400 (one tube, 275 ml)	592-900-003												
BOILER ACCESSORIES AND CONTROLS													
Boiler circulator, without flanges	<table border="0"> <tr> <td>Ultra-80/105</td> <td>Taco Model 007e ECM</td> <td>511-405-153</td> </tr> <tr> <td>Ultra-80/105</td> <td>Taco Model 007</td> <td>511-405-113</td> </tr> <tr> <td>Ultra-155/230/299</td> <td>Taco Model 0014</td> <td>511-405-133</td> </tr> <tr> <td>Ultra-399</td> <td>Taco Model 0013</td> <td>511-405-140</td> </tr> </table>	Ultra-80/105	Taco Model 007e ECM	511-405-153	Ultra-80/105	Taco Model 007	511-405-113	Ultra-155/230/299	Taco Model 0014	511-405-133	Ultra-399	Taco Model 0013	511-405-140
Ultra-80/105	Taco Model 007e ECM	511-405-153											
Ultra-80/105	Taco Model 007	511-405-113											
Ultra-155/230/299	Taco Model 0014	511-405-133											
Ultra-399	Taco Model 0013	511-405-140											
Circulator hardware kit – inlet (1 flange, 2 nuts, 2 screws, and 1 gasket)	<table border="0"> <tr> <td>1”</td> <td>381-354-525</td> </tr> <tr> <td>1¼”</td> <td>381-354-526</td> </tr> <tr> <td>1½”</td> <td>381-354-531</td> </tr> </table>	1”	381-354-525	1¼”	381-354-526	1½”	381-354-531						
1”	381-354-525												
1¼”	381-354-526												
1½”	381-354-531												
Low water cut-off with test button	511-100-005												
Heat exchanger cleaning tool	591-706-200												
Annual maintenance kit (Igniter, igniter gasket, cover plate gasket, cover plate insulation, burner gasket, flue sensor gasket and venturi gasket)	<table border="0"> <tr> <td>Ultra-80/105</td> <td>383-500-605</td> </tr> <tr> <td>Ultra-155 – 399</td> <td>383-500-620</td> </tr> </table>	Ultra-80/105	383-500-605	Ultra-155 – 399	383-500-620								
Ultra-80/105	383-500-605												
Ultra-155 – 399	383-500-620												
Pressure relief valve, ASME 30 PSI, 3/4” NPT male	<table border="0"> <tr> <td>Ultra-80 – 299</td> <td>383-500-095</td> </tr> <tr> <td>Ultra-80 – 399</td> <td>511-546-921</td> </tr> </table>	Ultra-80 – 299	383-500-095	Ultra-80 – 399	511-546-921								
Ultra-80 – 299	383-500-095												
Ultra-80 – 399	511-546-921												
Pressure/Temperature gauge, Short Shank 3.12-Inch Diameter 1/4 NPT	510-218-099												
Ultra boiler wall-mount kit	389-900-180												
VENT / AIR TERMINATIONS													
Vent/air termination wall penetrate cover plate (2 are shipped with each boiler)	383-500-100												
Vent termination bird screen (2 are shipped with each boiler)	<table border="0"> <tr> <td>3” vent - Ultra-80/105/155</td> <td>383-500-105</td> </tr> <tr> <td>4” vent - Ultra-230/299/399)</td> <td>383-500-110</td> </tr> </table>	3” vent - Ultra-80/105/155	383-500-105	4” vent - Ultra-230/299/399)	383-500-110								
3” vent - Ultra-80/105/155	383-500-105												
4” vent - Ultra-230/299/399)	383-500-110												
Weil-McLain sidewall vent/air cap termination kit — Includes W-M sidewall vent/air termination cap, inside and outside cover plates, and mounting hardware; openings are sized for PVC pipe.	<table border="0"> <tr> <td>3” kit - Ultra-80 – 155</td> <td>383-500-397</td> </tr> <tr> <td>4” kit - Ultra-230 – 399</td> <td>383-500-398</td> </tr> </table>	3” kit - Ultra-80 – 155	383-500-397	4” kit - Ultra-230 – 399	383-500-398								
3” kit - Ultra-80 – 155	383-500-397												
4” kit - Ultra-230 – 399	383-500-398												
Weil-McLain Flue Pipe & Adapter kits — Includes bracket pipe flue, adapter air Inlet, adapter flue pipe, clamp pipe flue, mounting hardware and Instructions:	<table border="0"> <tr> <td>70mm kit - Ultra-80/105</td> <td>383-500-770</td> </tr> <tr> <td>80mm kit - Ultra-155</td> <td>383-500-771</td> </tr> <tr> <td>100mm kit - Ultra-230-399</td> <td>383-500-772</td> </tr> </table>	70mm kit - Ultra-80/105	383-500-770	80mm kit - Ultra-155	383-500-771	100mm kit - Ultra-230-399	383-500-772						
70mm kit - Ultra-80/105	383-500-770												
80mm kit - Ultra-155	383-500-771												
100mm kit - Ultra-230-399	383-500-772												
Concentric vent kit (for sidewall or vertical termination)	3” PVC only												
Concentric vent kit (for sidewall or vertical termination)	4” PVC only												
CONDENSATE HANDLING													
Condensate neutralizer kit	383-500-631												

Go to www.weil-mclain.com to locate Weil-McLain distributors



Replacement parts *(continued)*

Figure 131 Jacket parts

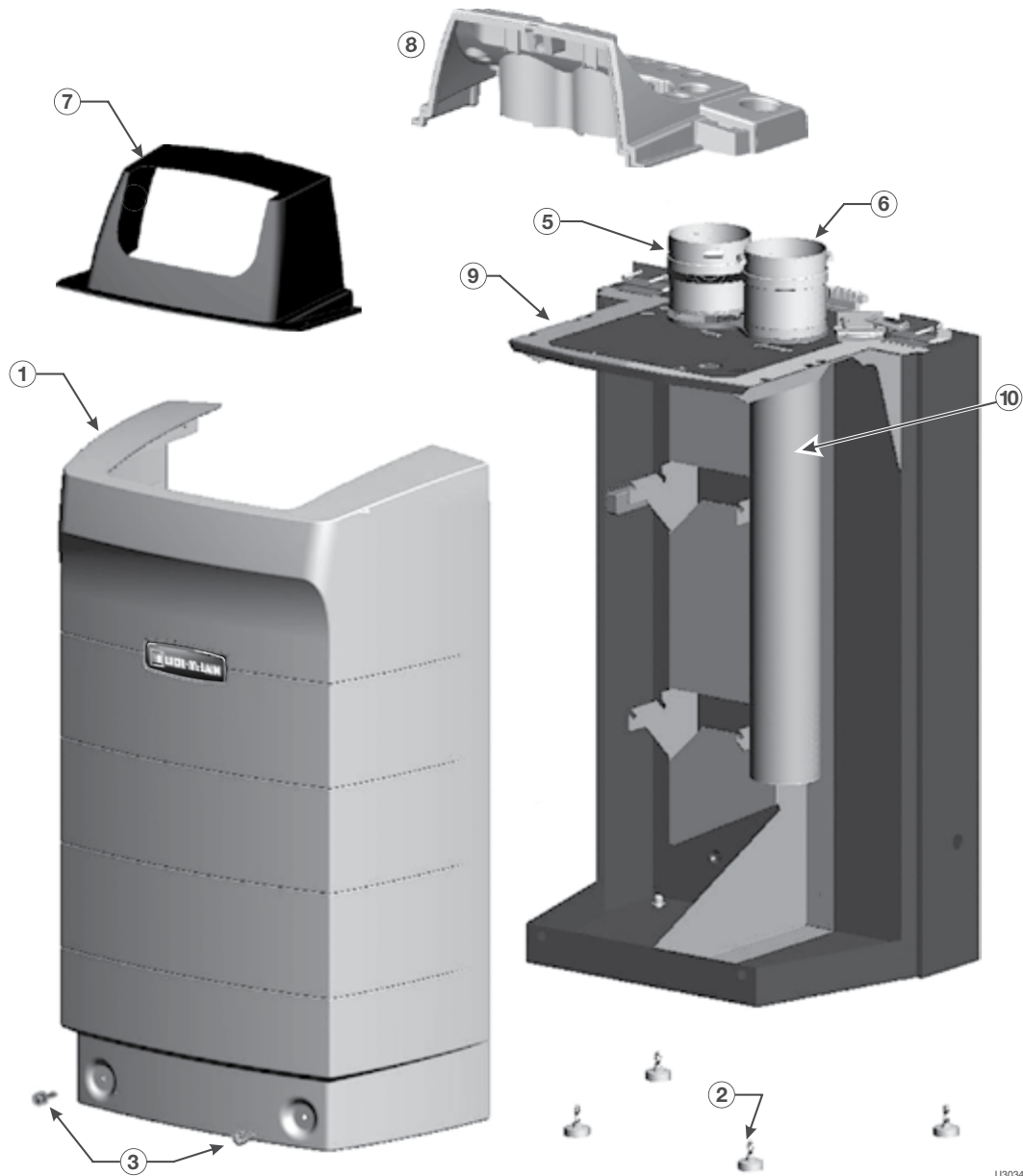

U3034

Item	Description	Boiler models	Part number
1	Jacket front door	All	383-500-135
2	Boiler leg kit (4 required)	All	383-500-065
3	Screw flat head slotted 17 Series for jacket front door (2 required)	All	562-650-126
4	Screw clip-on receptacle (not shown) (2 required)	All	383-500-180
5	Air inlet pipe adapter	3"	80/105 560-907-704
		3"	155 560-907-707
		4"	230-399 560-907-710

Item	Description	Boiler models	Part number
6	Flue outlet pipe adapter	3"	80/105 560-907-771
		3"	155 560-907-771
		4"	230-399 560-907-773
7	Top cover, front	All	383-500-607
8	Top cover, rear	80/230	383-500-608
		299/399	383-500-609
9	Door Gasket replacement kit (not shown)	All	383-500-610
10	Flue pipe	3"	80/105 560-907-775
		3"	155 560-907-772
		4"	230-399 560-907-774

Go to www.weil-mclain.com to locate Weil-McLain distributors

Replacement parts *(continued)*

Figure 132 Controls

Item	Description	Part Number
1	Ultra U-Control module	383-500-658
2	Transformer, 120V/24V	383-500-628
3	Display board assembly (includes plastic and display screen)	383-500-756
4	On/off power switch	383-500-205
5	Flue temperature sensor replacement kit	383-500-600
6	System temperature sensors (2 required)	383-500-601
7	Outdoor temperature sensor	510-312-218
8	Display to U-Control wire harness (not shown)	383-500-633
9	Line voltage wire harness (male) (not shown)	383-500-639
10	Low voltage wire harness (male) (not shown)	383-500-640
11	120 volt, 3-wire receptacle (not shown)	383-500-638
12	Ultra U-Control module fuses (not shown) F1 - 3-amp, fast-blow ATO (5 fuses) F2 - 12-amp, fast-blow AG (5 fuses)	383-500-603 383-500-604
13	Jumper for low voltage terminal blocks, (5 jumpers) (not shown)	383-500-641
14	Ultra U-Control terminal block kit, (includes 1 high voltage terminal block, 6 low voltage terminal blocks, and U-Control screwdriver) (not shown)	383-500-642
15	24V LWCO kit with quick connect harness (not shown)	511-100-005

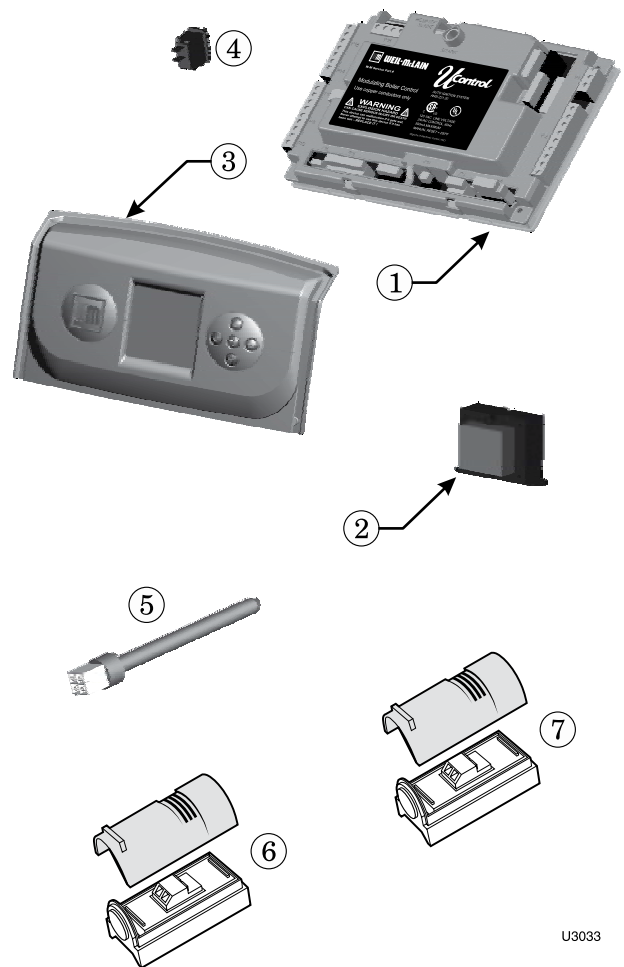

U3033



Replacement parts *(continued)*

Figure 133 Heat exchanger and piping — Ultra-80 and -105

Item	Description	Boiler Models	Part Number
1	Heat exchanger replacement kit - Heat exchanger, cover plate, burner, electrode, water sensors, compression fittings, condensate fitting, gaskets, and hardware	80NG 80LP 105	383-500-670 383-500-671 383-500-672
2	Cover plate replacement kit - Cover plate, cover plate gasket, burner gasket, and hardware	80/105	383-501-022
3	Cover plate gasket/insulation	80/105	383-500-251
4	Burner gasket	80/105	590-300-000
5	Cover plate studs, M6, 1 pitch	All	560-340-598
6	Cover plate nuts, M6, 1 pitch	All	561-928-449
7	Water compression fitting, 28 mm	80-230	383-500-260
8	Water compression fitting, 22 mm	80/105	564-100-002
9	Supply water pipe assembly - Pipe, compression fitting & plugs	80/105	383-500-760
10	Return water pipe assembly - Pipe, drain valve (assembled) & compression fitting	80/105	383-500-761
11	Boiler drain valve, 3/4" NPT	All	511-246-392
12	Blower assembly kit - Blower, gasket, and hardware	80/105	383-501-027
13	Gas pipe	80/105	560-907-682
14	Flexible gas line	80/105	383-500-616
15	Gas Pipe lower pipe clamp and hardware	80/105	383-500-617
16	Gas valve/venturi kit - Gas valve, venturi, 90° elbow, gaskets, and hardware (assembled) (For LP boilers, make sure to reinstall the existing propane orifice)	80 105	383-501-029 383-501-030
17	Gasket cork, for in between gas valve venturi & burner inlet	All	590-317-310
18	Air silencer kit - Air silencer and gasket	80/105	383-501-026
19	Air silencer adapter kit - Air silencer adapter and hardware	80/105	383-501-025
20	Condensate trap kit - Condensate trap, hose clamps, pvc fittings, and gasket	80/105	383-501-031
21	Return/supply sensor kit - (1) sensor	All	383-500-602
22	Ignition electrode kit - Ignition electrode, suppressor, gasket, and hardware	All	383-500-045
	Ignition electrode gasket ONLY	All	511-330-253
23	Ignition cable kit (not shown) - Ignition cable, suppressor, and wire tie	All	383-500-619
24	Inspection glass kit - Bracket, glass, gasket and hardware	All	383-500-020
25	Burner replacement kit - Burner, gaskets and hardware	80NG 80LP 105	383-501-032 383-501-033 383-501-034
26	Gasket rubber, blower	80/105	590-300-003
27	Condensate fitting	80/105	561-200-000



Replacement parts *(continued)*

Figure 134 Heat exchanger and piping — Ultra-80 and -105

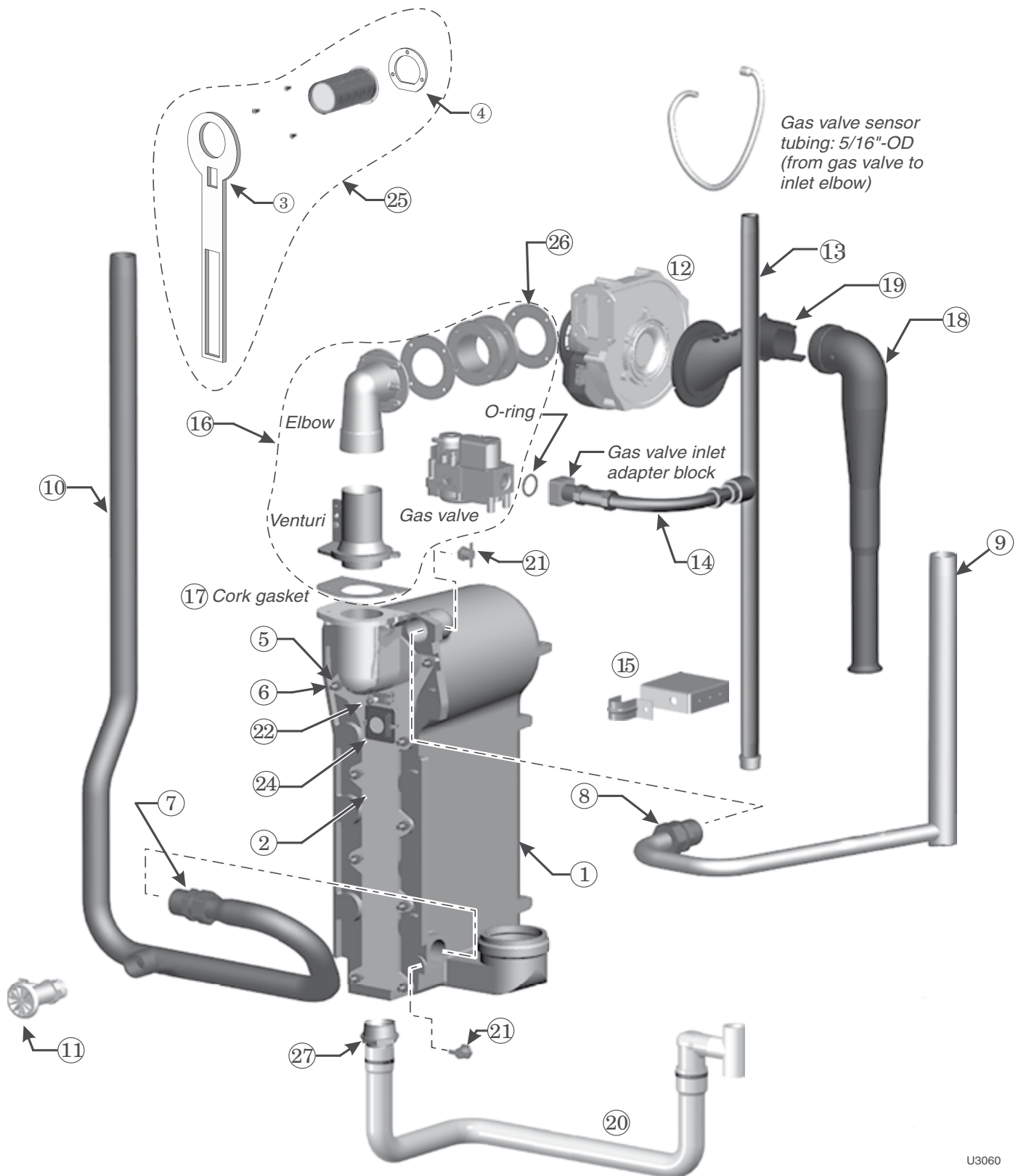

Go to www.weil-mclain.com to locate Weil-McLain distributors



Replacement parts *(continued)*

Figure 135 Heat exchanger and piping
Ultra-155 & -230

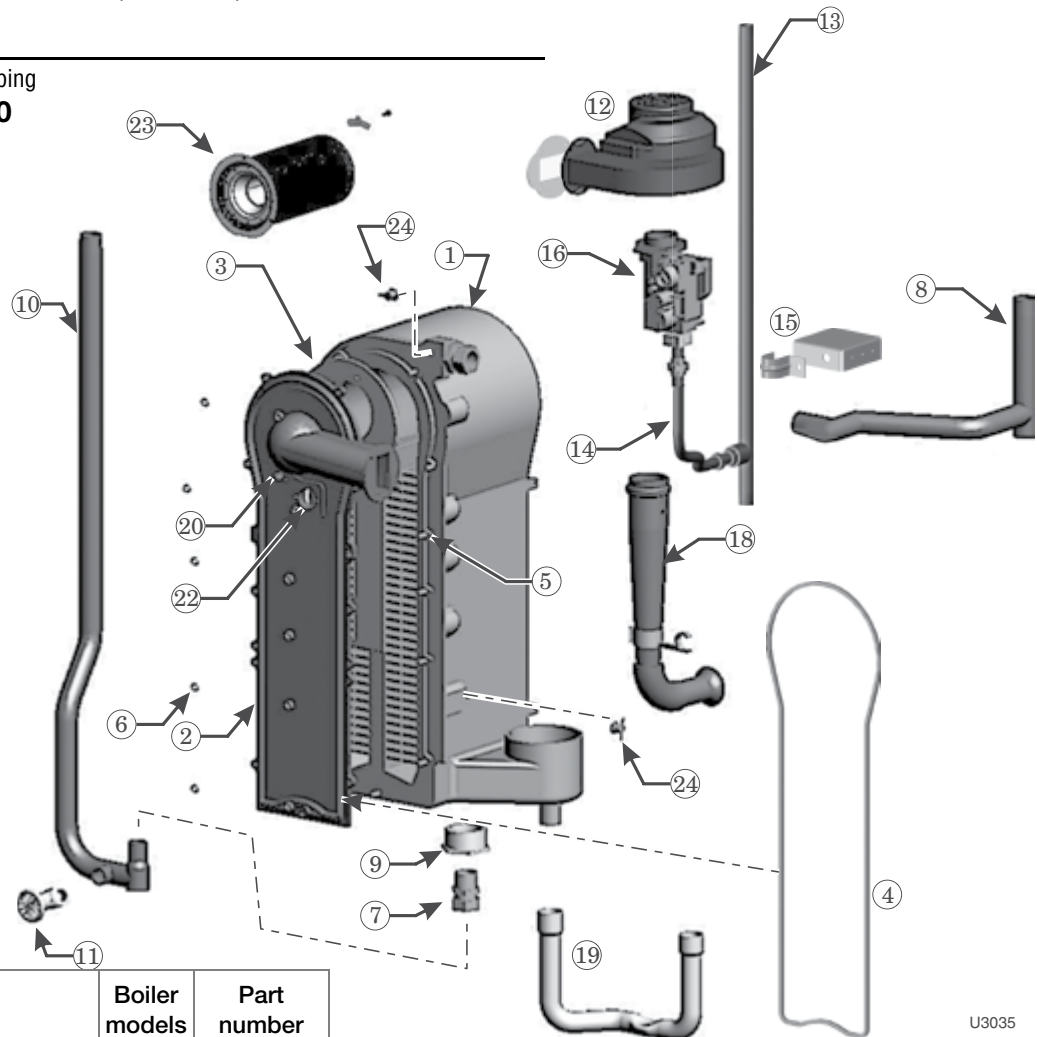

U3035

Item	Description	Boiler models	Part number
1	Heat exchanger replacement kit - Heat exchanger, cover plate, burner, electrode, water sensors, compression fittings, condensate fitting, gaskets, and hardware	155 230	383-500-673 383-500-674
2	Cover plate replacement kit - Cover plate, cover plate gasket, burner gasket, and hardware	155/230	383-500-395
3	Cover plate insulation	155/230	383-500-250
4	Cover plate gasket	155/230	383-500-255
5	Cover plate studs, M6, 1 pitch	All	560-340-598
6	Cover plate nuts, M6, 1 pitch	All	561-928-449
7	Water compression fitting, 28 mm	80-230	383-500-260
8	Supply water pipe assembly - Pipe & compression fitting & plugs	155/230	383-500-762
9	Return water bushing, 1 1/4" BSP x 1" BSP (not use on Ultra-299)	155/230	383-500-280
10	Return water pipe assembly - Pipe, drain valve, cap (assembled) & compression fitting	155/230	383-500-763
11	Boiler drain valve, 3/4" NPT	All	511-246-392
12	Blower assembly kit - Blower, gasket, and hardware	155 230	383-500-035 383-500-040
13	Gas pipe	155/230	560-907-683
14	Flexible gas line	155/230	383-500-767
15	Gas pipe lower clamp and hardware	155/230	383-500-617

Item	Description	Boiler models	Part number
16	Gas valve/venturi kit - Gas valve, venturi, adapter block, O-ring and hardware (assembled) be sure to reinstall the existing propane orifice)	155 230	383-500-025 383-500-030
17	Gasket cork, for in between gas valve venturi & blower inlet (not shown)	All	590-317-310
18	Air silencer kit - Air silencer and gasket	155/230	383-500-295
19	Condensate trap kit - Condensate trap, hose clamps, pvc fittings, and gasket	155/230	383-500-060
20	Ignition electrode kit - Ignition electrode, suppressor, gasket, and hardware Ignition electrode gasket ONLY (not shown)	All	383-500-045 511-330-253
21	Ignition cable kit (not shown) - Ignition cable, suppressor, and wire tie	All	383-500-619
22	Inspection glass kit - Bracket, glass, gasket and hardware	All	383-500-020
23	Burner replacement kit - Burner, gaskets and hardware	155 230	383-500-085 383-500-090
24	Return/supply sensor kit - (1) sensor	All	383-500-602

Go to www.weil-mclain.com to locate Weil-McLain distributors

Replacement parts *(continued)*

Figure 136 Heat exchanger and piping **Ultra-299 & -399**

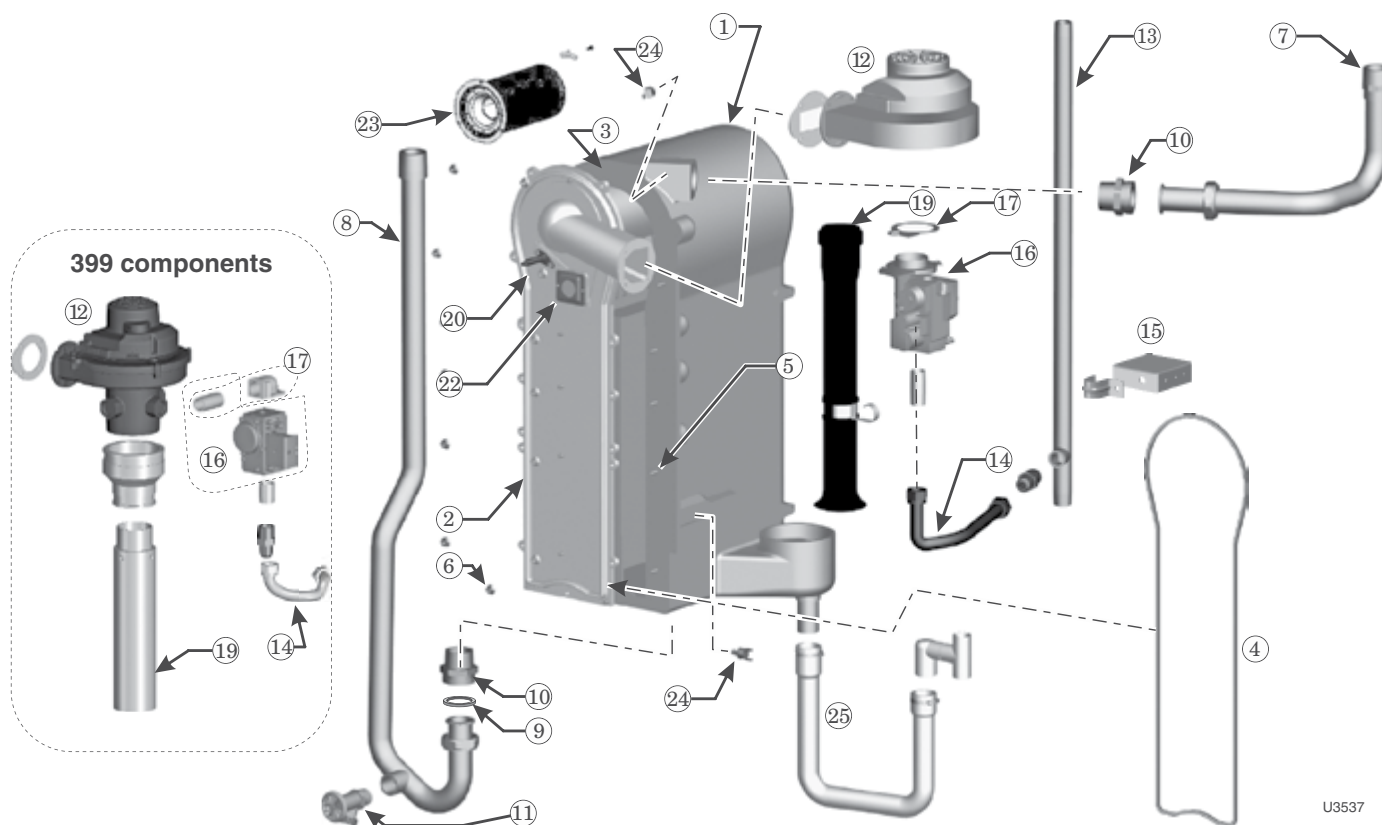

U3537

Item	Description	Boiler models	Part number	Item	Description	Boiler models	Part number
1	Heat exchanger replacement kit - Heat exchanger, cover plate, burner, electrode, water sensors, compression fittings, condensate fitting, gaskets, and hardware	299/399	383-500-675	16	Gas valve/venturi kit - Gas valve, venturi Gas valve kit - Gas valve, venturi, adapter block, O-ring and hardware (assembled)	299 399	383-500-390 383-500-652
2	Cover plate replacement kit - Cover plate, cover plate gasket, burner gasket, and hardware	299/399	383-500-395	17	Gas valve outlet adapter/nipple kit	399	383-500-651
3	Cover plate insulation	299/399	383-500-250	18	Gasket cork, for in between gas valve venturi & blower inlet	All	590-317-310
4	Cover plate gasket	299/399	383-500-255	19	Air silencer kit - Air silencer and gasket	299 399	383-500-355 383-500-654
5	Cover plate studs, M6, 1 pitch	All	560-340-598	20	Ignition electrode kit - Ignition electrode, suppressor, gasket, and hardware Ignition electrode gasket ONLY	All	383-500-045 511-330-253
6	Cover plate nuts, M6, 1 pitch	All	561-928-449	21	Ignition cable kit (not shown) - Ignition cable, suppressor, and wire tie	All	383-500-619
7	Supply water pipe assembly - Pipe & compression fitting & plugs	299/399	383-500-764	22	Inspection glass kit - Bracket, glass, gasket and hardware	All	383-500-020
8	Return water pipe assembly - Pipe, drain valve, cap (assembled) & compression fitting	299/399	383-500-385	23	Burner replacement kit - Burner, gaskets and hardware	299	383-500-407
9	Supply/Return water piping square cut EPDM gasket (Ultra-299 only)	299/399	562-248-755	24	Return/supply sensor kit - (1) sensor	All	383-500-602
10	Fitting, double nipple for supply/return	299/399	561-326-828	25	Condensate trap kit - Condensate trap, hose clamps, pvc fittings, and gasket	299/399	383-500-626
11	Boiler drain valve, 3/4" NPT	All	511-246-392				
12	Blower assembly kit - Blower, gasket, and hardware	299 399	383-500-360 383-500-650				
13	Gas pipe	299/399	560-907-679				
14	Flexible gas line	299/399	383-500-768				
15	Gas pipe lower clamp and hardware	299	383-500-625				



Dimensions

Figure 137 Dimensional data

- ① Supply connection (*note 1*)
- ② Return connection (*note 1*)
- ③ Control panel
- ④ Electrical entrance openings
- ⑤ Vent connection:
Ultra-80/105/155 — 3"
Ultra-230/299/399 — 4"

■ ALL DIMENSIONS IN INCHES ■

- ⑥ Gas connection (*note 1*)
- ⑦ Drain valve (inside enclosure)
- ⑧ Condensate drain (½" PVC)
- ⑨ Air connection:
Ultra-80/105/155 — 3"
Ultra-230/299/399 — 4"

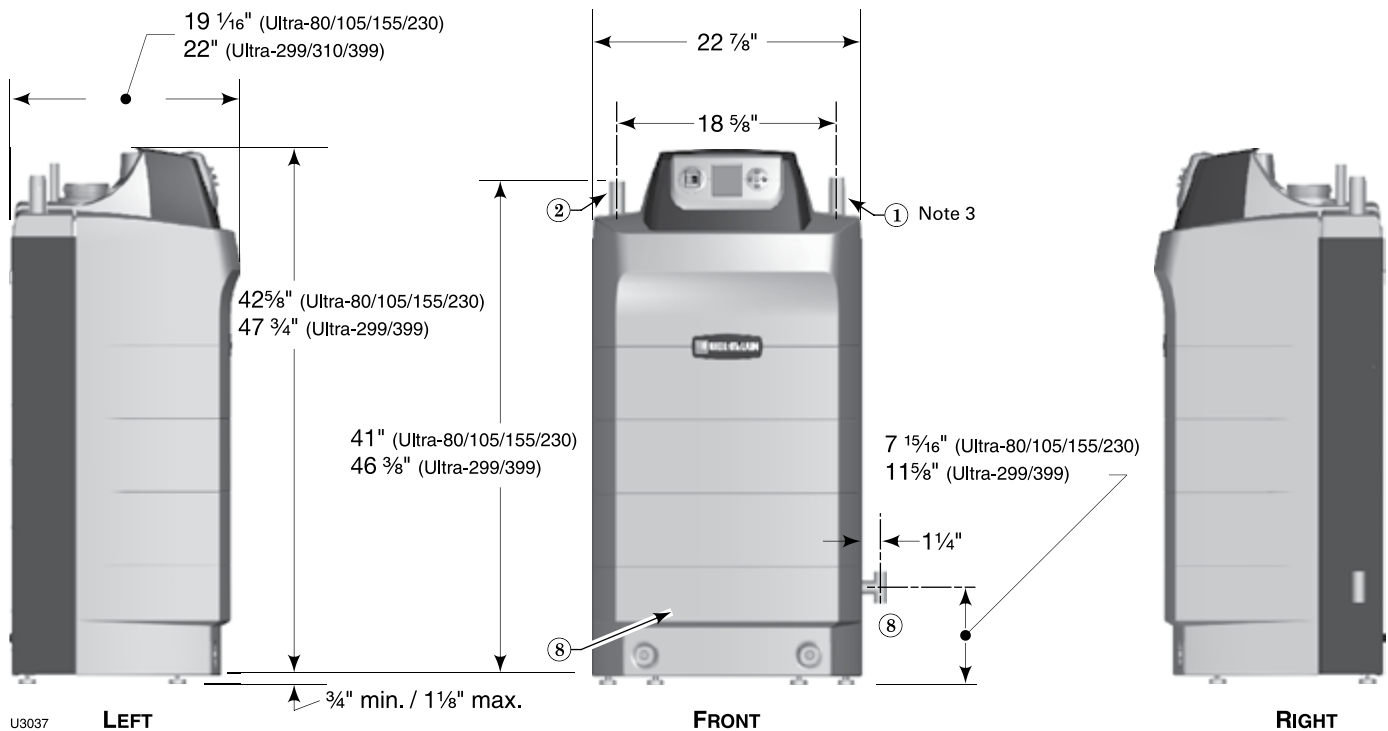
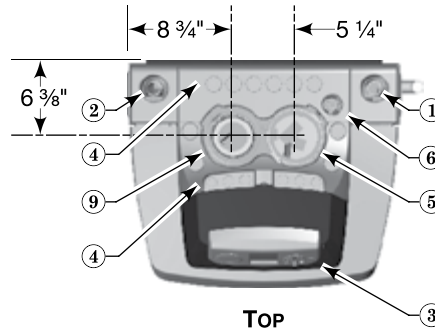

U3037

Notes

1	Boiler supply and return tapings are both 1" NPT (Ultra-80/105/155/230) or 1¼" NPT (Ultra-299/399). See page 10 for recommended piping sizes. Wall-hung boiler option — water piping and gas pipe can only be routed through top of enclosure using wall-mounting kit. See page 5 for mounting instructions.
2	Boiler circulator is shipped loose. Circulator must be mounted in the return piping. Both 1" and 1¼" circulator flanges are shipped with boiler on Ultra-80/105/155/230. Both 1¼" and 1½" circulator flanges are shipped with boiler on Ultra-299 and Ultra-399.
3	Relief valve is shipped loose. See page 9 for mounting details. Relief valve mounts on supply pipe off of supply tee and ¾" street elbow as shown.



Ratings — Ultra Series 4 boilers

Figure 138 Ratings and engineering data

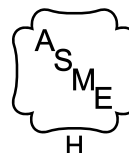

AHRI Certified Ratings

Boiler Model Number	CSA Input	Heating Capacity	Seasonal Efficiency	Net Rating (water)	Boiler Water Content	Vent/Air Pipe Size
	Btuh (Note 7)	Btuh (Note 2 and 7)	AFUE % (Note 1)	Btuh (Note 3)	Gallons	(Note 4)
Ultra-80	80,000	71,000	93.5	62,000	0.69	2" or 3"
Ultra-105	105,000	94,000	94.0	82,000	0.82	2" or 3"
Ultra-155	155,000	139,000	94.0	121,000	1.17	3"
Ultra-230	230,000	207,000	94.1	180,000	1.57	3" or 4"
Ultra-299	299,000	270,000	92.5	235,000	2.10	4"

Boiler Model Number	CSA Input	Gross Output	Net AHRI Ratings	Combustion Efficiency	Thermal Efficiency	Boiler Water Content	Vent/Air Pipe Size
	Btuh (Note 7)	Btuh (Note 7)	Btuh (Note 3)	% (Note 5)	% (Note 6)	Gallons	(Note 4)
Ultra-399	399,000	364,000	317,000	91.7	91.3	2.10	4"

Notes

- 1** As an Energy Star Partner, Weil-McLain has determined that Ultra boilers meet the Energy Star guidelines for energy efficiency. NOTE: Adjusting boiler firing rate will affect AFUE rating.
- 2** Based on standard test procedures prescribed by the United States Department of Energy.
- 3** Net AHRI ratings are based on net installed radiation of sufficient quantity for the requirements of the building and nothing need be added for normal piping and pickup. Ratings are based on a piping and pickup allowance of 1.15. An additional allowance should be made for unusual piping and pickup loads.
- 4** Ultra boilers require special venting, consistent with Category IV boiler. Use only the vent materials and methods specified in this manual. Ultra-80 and -105 vent/air pipes can be either 2" or 3" pipe. Vent/air pipe length limits for 2" piping are not as long as for 3" piping. Ultra-230 vent/air pipes can be either 3" or 4" pipe. Vent/air pipe length limits for 3" piping are not as long as for 4" piping.
- 5** Combustion efficiency is based on AHRI testing procedure BTS-2000, and equal to 100% minus flue loss.
- 6** Thermal efficiency is based on AHRI testing procedure BTS-2000.
- 7** Ratings shown are for sea level applications only. For altitudes from sea level to 5,500 feet above sea level, the Ultra boiler requires no modifications and automatically derates itself by approximately 4% per 1000 feet above sea level.

THE OUTDOOR SENSOR SUPPLIED WITH THE BOILER MUST BE INSTALLED UNLESS EXEMPTED BELOW: **IMPORTANT**

In accordance with **Section 303 of the 2007 Energy Act**, this boiler is equipped with a feature that saves energy by reducing the boiler water temperature as the heating load decreases. This feature is equipped with an override which is provided primarily to permit the use of an external energy management system that serves the same function.

THIS OVERRIDE MUST NOT BE USED UNLESS AT LEAST ONE OF THE FOLLOWING CONDITIONS IS TRUE:

- An external energy management system is installed that reduces the boiler water temperature as the heating load decreases.
- This boiler is not used for any space heating.
- This boiler is part of a modular or multiple boiler system having a total input of 300,000 BTU/hr or greater.
- This boiler is equipped with a tankless coil (not applicable to Ultra boilers).



Ratings — Multiple Ultra Series 4 boilers

Figure 139 Ratings and engineering data (Figure 141 for notes)

Boilers in system Model Ultra –						Total CSA input	DOE Heating capacity	Boiler H.P.	Net water ratings	Manifolded combustion air duct size	Foundation size			
											Side-to-side arrangement <i>(height 2" to 4")</i>		Back-to-back arrangement <i>(height 2" to 4")</i>	
											Length (inches)	Length (inches)	Length (inches)	Length (inches)
80	105	155	230	299	399	-	Note 1	-	Note 2	Figure 59, page 59	Note 3			
2						160	142	4.2	123	80	56	23	27	48
	2					210	188	5.6	163	105				
		2				310	278	8.3	242	155				
			2			460	414	12.4	360	230				
				2		598	540	16.1	468	299				
					2	798	730	21.8	634	385				
3						240	213	6.4	185	120	85	23	56	48
	3					315	282	8.4	245	157				
		3				465	417	12.5	363	232				
			3			690	621	18.6	540	345				
				3		897	810	24.2	702	449				
					3	1197	1095	32.7	951	578				
4						320	284	8.5	247	160	114	24	56	49
	4					420	376	11.2	327	210				
		4				620	556	16.6	483	310				
			4			920	828	24.7	720	460				
				4		1196	1080	32.3	936	598				
					4	1596	1460	43.6	1268	770				
5						400	355	10.6	309	200	143	24	85	49
	5					525	470	14	409	267				
		5				775	695	20.8	604	387				
			5			1150	1035	30.9	900	575				
				5		1495	1350	40.3	1170	748				
					5	1995	1825	54.5	1585	963				
6						480	426	12.7	370	240	172	24	85	49
	6					630	564	16.8	490	315				
		6				930	834	24.9	725	465				
			6			1380	1242	37.1	1080	690				
				6		1794	1620	48.4	1404	897				
					6	2394	2190	65.4	1902	1155				
7						560	497	14.8	432	280	201	24	114	49
	7					735	658	19.7	572	367				
		7				1085	973	29.1	846	542				
			7			1610	1449	43.3	1260	805				
				7		2093	1890	56.5	1638	1047				
					7	2793	2555	76.3	2219	1348				
8						640	568	17	494	320	230	24	114	49
	8					840	752	22.5	654	420				
		8				1240	1112	33.2	967	620				
			8			1840	1656	49.5	1440	920				
				8		2392	2160	64.5	1872	1196				
					8	3192	2920	87.2	2536	1539				



Ratings — Multiple Ultra Series 4 boilers *(continued)*

Figure 140 Engineering data (see Figure 141 for notes)

Boiler Model	Shipping weight	Operating weight	Water content	Water flow rate per boiler		Vent/air pipe size — Provide a separate vent for each boiler	Electrical service required
	Pounds per boiler	Pounds per boiler Note 4	Gallons per boiler	GPM @ 20°F rise	GPM @ 40°F rise		Amps per boiler Note 6
-80	199	139	0.7	7.1	3.6	2" or 3"	15.0
-105	207	145	0.8	9.4	4.7	2" or 3"	15.0
-155	234	181	1.2	13.9	7.0	3"	15.0
-230	246	192	1.6	20.7	10.4	3" or 4"	15.0
-299	297	229	2.1	27.9	14.0	4"	15.0
-399	297	229	2.1	36.5	18.2	4"	15.0

Figure 141 Notes for Figure 139 and Figure 140

1	Based on standard test procedures outlined by DOE for individual boilers.
2	Net AHRI ratings are based on piping and pickup allowance of 1.15. Consult Weil-McLain Technical Services for other allowances.
3	Foundation sizes in Figure 139 provide 6 inches between boilers and 2 inches from boiler to edge of foundation. Smaller foundations are possible with reduced service clearances. See page 58 for details. <ul style="list-style-type: none"> • For side-to-side installations, see Figure 56, page 58. • For back-to-back installations, see Figure 57, page 58.
4	Operating weight is the total weight of the boiler, including water.
5	Ultra-80 and -105 vent/air pipes can be either 2" or 3" pipe. Vent/air pipe length limits for 2" piping are not as long as for 3" piping. Ultra-230 vent/air pipes can be either 3" or 4" pipe. Vent/air pipe length limits for 3" piping are not as long as for 4" piping. All Ultra installations require a separate vent pipe and termination for each boiler. Vent piping cannot be manifolded. Install and terminate vents as described in vent/air installation instructions in this manual. Combustion air piping can be individually piped or manifolded. See Figure 59, page 59, for manifolded air piping.
6	Total amp requirement includes up to three circulators, not exceeding 2.2 amps per circulator.



Installation and Service Certificate

Boiler Model _____ Series _____ CP Number _____ Date Installed _____

- BTU Input _____
- Installation instructions have been followed.
 - Check-out sequence has been performed.
 - Above information is certified to be correct.
 - Information received and left with owner/maintenance person.

Installer _____

(Company) (Address)

(Phone) (Installer's Signature)

START-UP DATA					
Boiler Model		CO ₂ High fire	%	CO ₂ Low fire	%
Fuel	Natural ____ LP ____	CO High fire	ppm	CO Low fire	ppm
Was orifice changed? _____		Was gas valve throttle adjusted (Ultra-399) for propane? _____			
Natural gas input rate measured _____ Btuh					
U-CONTROL SET-UP DATA					
Boiler Model		WWSD Temp	°F	Add'l Heat Demand Type	1 ____ 2 ____ 3 ____ 4 ____
High Altitude	yes ____ no ____	Adjust Outdoor	°F	Add'l Heat Demand Time	minutes
Manual Reset Temp			°F		
PRIORITY 1 Settings		PRIORITY 2 Settings		PRIORITY 3 Settings	
System Type		System Type		System Type	
Max Supply	°F	Max Supply	°F	Max Supply	°F
Min Supply	°F	Min Supply	°F	Min Supply	°F
Max OD Reset	°F	Max OD Reset	°F	Max OD Reset	°F
Min OD Reset	°F	Min OD Reset	°F	Min OD Reset	°F
Modulate On Diff	°F	Modulate On Diff	°F	Modulate On Diff	°F
Modulate Off Diff	°F	Modulate Off Diff	°F	Modulate Off Diff	°F
Max On Time	minutes	Max On Time	minutes	Max On Time	—
Min On Time	—	Min On Time	minutes	Min On Time	minutes
Boost Interval	minutes	Boost Interval	minutes	Boost Interval	minutes
Pre-pump Time:	seconds	Pre-pump Time:	seconds	Pre-pump Time:	seconds
Post-pump Time:	seconds	Post-pump Time:	seconds	Post-pump Time:	seconds
Circulator 1	on-off	Circulator 1	on-off	Circulator 1	on-off
Circulator 2	on-off	Circulator 2	on-off	Circulator 2	on-off
Circulator 3	on-off	Circulator 3	on-off	Circulator 3	on-off
Maximum Rate	%Rate	Maximum Rate	%Rate	Maximum Rate	%Rate
Minimum Rate	%Rate	Minimum Rate	%Rate	Minimum Rate	%Rate
Circulator Exercising			Freeze Protection Circulators		
Circulator 1	on _____ off _____	Circulator 1	on _____ off _____		
Circulator 2	on _____ off _____	Circulator 2	on _____ off _____		
Circulator 3	on _____ off _____	Circulator 3	on _____ off _____		