



ECO-VALVE

Figure # 5044AB

Low Lead Brass Ball Valve (1/2"-2")

Product Features

- 150# WSP / 600# WOG
- Forged Brass Body
- Full Port
- Adjustable Packing
- Threaded Ends
- Blow-Out Proof Stem
- MSS-SP-110
- 550 PSI (1-1/2", 2") for UL use
- CSA 1/2, 5 & 125 PSI
- UL Approved
- FM Approved
- AB1953 Certified



Certified to ANSI/NSF 61

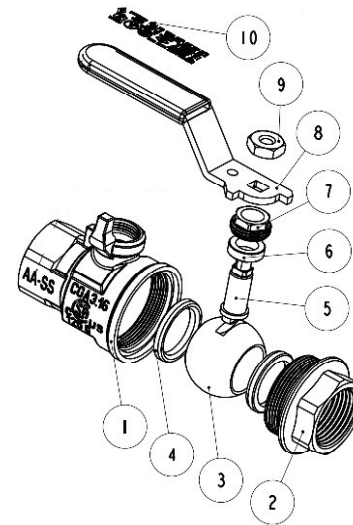

Pressure/Temperature Rating	
600 PSI from 15°F to 160°F	150 PSI MAX at 366°F

Materials & Specifications

Item	Description	Material	Specification
1	Body	Low Lead Brass	CW510L
2	End piece	Low Lead Brass	CW510L
3	Ball	Low Lead Brass/Cr Plated	CW510L
4	Seat	PTFE	PTFE
5	Stem	Low Lead Brass	CW510L
6	Packing	PTFE	PTFE
7	Packing nut	Brass	B124 C37700
8	Handle	Dacromet Steel	A36 Dacromet
9	Handle nut	Zinc Plated Steel	A36
10	Valve info	-	-

Dimensions, Weights (inches-lbs.) & Valve Data

Size	1/2	3/4	1	1-1/4	1-1/2	2
A	2.13	2.56	2.92	3.39	3.90	4.45
C	0.55	0.59	0.71	0.73	0.77	0.81
H	2.13	2.26	2.57	2.79	3.28	3.58
L	3.60	3.60	4.98	4.98	5.57	5.57
P	0.59	0.79	0.98	1.26	1.57	1.97
Wt	0.56	0.83	1.36	2.15	3.09	4.87

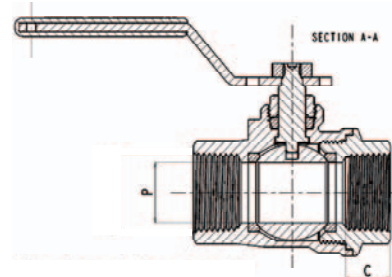
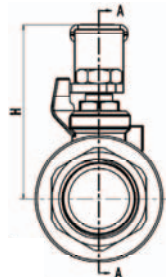
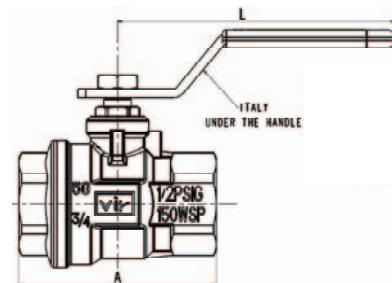

RED-WHITE VALVE CORP.

20600 Regency Lane, Lake Forest, CA 92630

TEL: 949.859.1010 • FAX: 949.859.7200 • www.redwhitevalvecorp.com