

45601-1

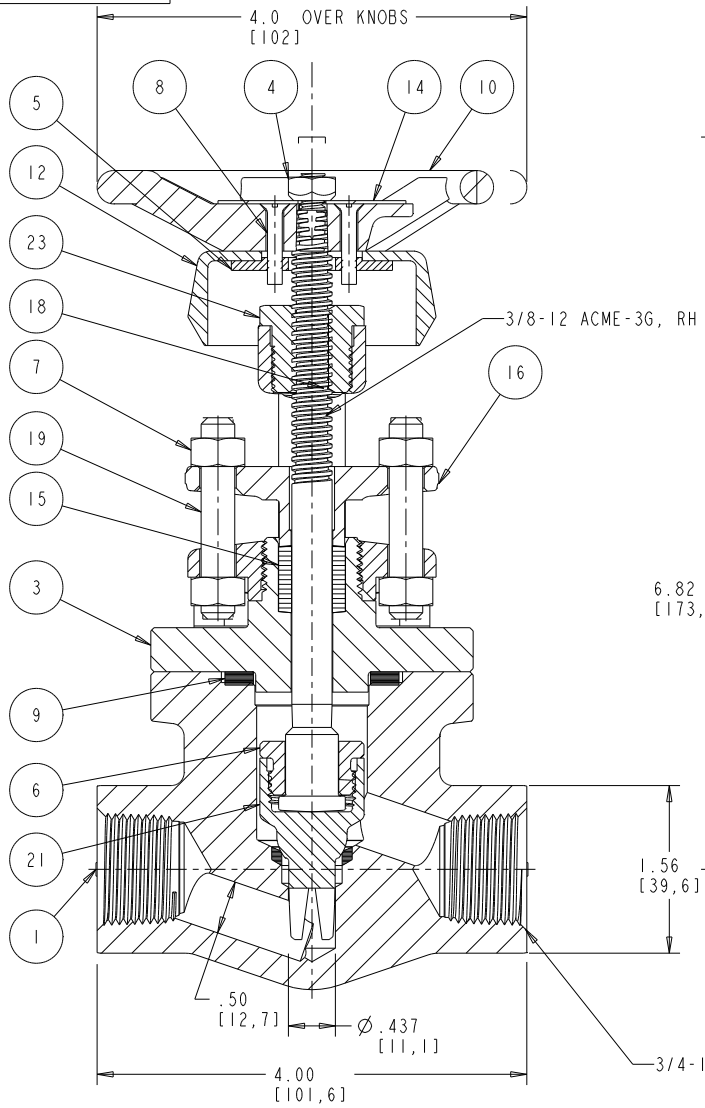

SECTION A-A

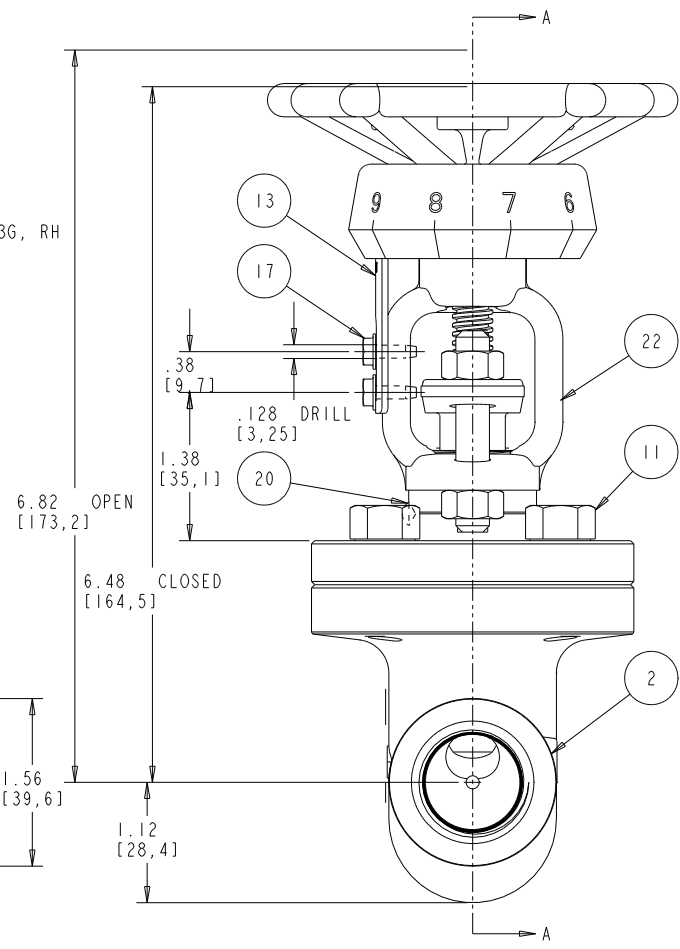

ITEM	QTY	ITEM NO	DRAWING	PART NAME	MATERIAL
1	2	58405		3/4 THD PROTECTOR	POLYETHYLENE
2	1	20873	44826	BODY	A105 (HFS)
3	1	30147	35003	BONNET	A105
4	1	50009	60679A	CS LOCK NUT	A105
5	1	50242	52163	DIAL WASHER	A105
6	1	32488	44273	DISK NUT	A479 TYPE 410
7	4	50221	60684A	FINISHED HEX NUT	F594 304SS
8	2	50016		FLAT HEAD SCREW	MFG. STD.
9	1	55002	45706B	GASKET	304/GRAFOIL
10	1	35003	53763T	HANDWHEEL	CAST IRON
11	4	50026	45417A	HEX HD BOLT	A193 GR B7
12	1	58328	39033A	INDICATOR DIAL	TYPE 347
13	1	58333	38756	INDICATOR SCALE	A182 TYPE 304
14	1	40235	28297	NAME PLATE	ALUMINUM
15	1	55175		PACKING CARTRIDGE	FLEXIBLE GRAPHITE
16	1	34070	35005	PACKING GLAND	A105
17	2	50015		SELF TAPPING SCREW	ZINC PLATED
18	1	32889	49961	STEM	A479 TYPE 410
19	2	50120	21912	STUD BOLT	F593 304SS
20	1	58452		TACK WELD	(RMPWPS555)
21	1	32384	44828	THROTTLING DISC	A479 TYPE 410
22	1	34015	35130	YOKE	A105
23	1	58108	26857	YOKE NUT	A582 TYPE 416

NOTE: SET DIAL & INDICATOR TO "0" AT ASSEMBLY WHEN VALVE IS CLOSED.
- 4 TURNS TO OPEN (APPROX)

NOTE: VALVE TO BE TESTED PER MSS-SP-61 PER RMPVFLT005

	X.XX Inches [XX,X] MM	
WEIGHT	5.9 LBS	2.66 Kg
Cv FACTOR	2.4	

CNS	58644	DWN BY	J.CECIL
REV	14	CHK BY	S.B.R.
BY	R.Jackson	RVD BY	
DATE	2-18-2005	DATE	9-19-67

SERIES No:	12443-05
ITEM No:	202284
RATING: 1975 PSI @ 100 F	SPECS: ASME B16.34
BODY A105 SEAT INTG HF DISC 13CR STEM 13CR	

FLOWERVE Vogt Valves

SULPHUR SPRINGS, TEXAS, USA

3/4 GLOBE VALVE - THROTTLING
FORGED STEEL-OS&Y-BOLTED BONNET-BOLTED GLAND
- INTEGRAL SEAT - THREADED V-PORT DISC
THREADED ENDS - CLASS 800

45601-1