

Lead-Free* Bronze Ring Check® Valves

Features: Silicon Performance Bronze® Alloy • Inline Lift Type • Resilient Discs • Spring Actuated

Approvals: conforms to MSS SP-139 • NSF/ANSI-61-8 Commercial Hot 180°F (includes annex F and G) and NSF/ANSI-372

Size range: 1/2" - 2"

Pressure rating: 250 PSI non-shock cold working pressure

Maximum pressure / temperature: 100 PSI at 300° F

Lead-free* marking:

Double oval in body casting



NSF/ANSI 61
NSF/ANSI 372

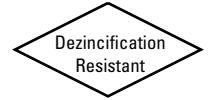

T-480-Y-LF

Threaded



S-480-Y-LF

Solder

MATERIAL LIST

PART	SPECIFICATION
1. Body	Silicon Bronze ASTM B584 Alloy C87850
2. Stem	Stainless Steel ASTM A582 Alloy S30300
3. Spring	Stainless Steel S31600
4. Disc Holder	Stainless Steel S31600
5. Disc	PTFE
6. Seat Screw	Stainless Steel ASTM A276 Alloy S43000
7. Body End	Silicon Bronze ASTM B584 Alloy C87850

DIMENSIONS—WEIGHTS—QUANTITIES

SIZE	A		B		C		D		E		T-480-Y-LF		Master Ctn Qty.	
	In.	mm.	In.	mm.	In.	mm.	In.	mm.	In.	mm.	Lbs.	Kg.		
1/2	15	2.06	52	0.5	13	1.03	26	0.53	13	1.37	35	0.36	0.16	100
3/4	20	2.25	57	0.75	19	1.12	28	0.61	15	1.63	41	0.48	0.22	100
1	25	2.63	67	1	25	1.29	33	0.72	18	2.08	53	0.77	0.35	50
1-1/4	32	2.94	75	1.25	32	1.47	37	0.59	15	2.39	61	1.14	0.51	30
1-1/2	40	3.31	84	1.5	38	1.77	45	0.84	21	2.76	70	1.63	0.74	30
2	50	3.69	94	2	51	2.19	56	0.84	21	3.39	86	2.27	1.03	10

SIZE	A		B		C		D		E		S-480-Y-LF		Master Ctn Qty.	
	In.	mm.	In.	mm.	In.	mm.	In.	mm.	In.	mm.	Lbs.	Kg.		
1/2	15	2.17	55	0.5	13	1.19	30	0.5	13	1.37	35	0.40	0.18	100
3/4	20	2.78	71	0.75	19	1.31	33	0.75	19	1.63	41	0.52	0.24	100
1	25	3.31	84	1	25	1.5	38	0.91	23	2.08	53	0.85	0.39	50
1-1/4	32	3.54	90	1.25	32	1.6	41	0.97	25	2.39	61	1.28	0.58	30
1-1/2	40	4.1	104	1.5	38	1.92	49	1.09	28	2.76	70	1.75	0.79	30
2	50	4.96	126	2	51	2.28	58	1.34	34	3.39	86	2.70	1.23	10

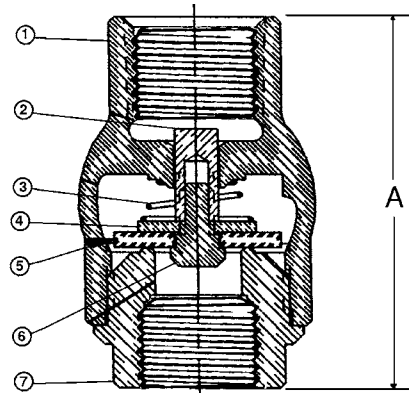

T-480-Y-LF
NPT x NPT

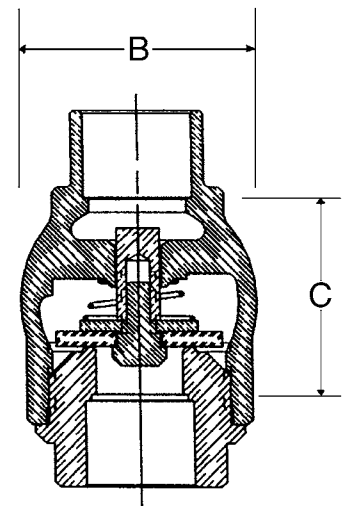

S-480-Y-LF
C x C

1/2" thru 2" require 1/2 pound pressure to open

NIBCO check valves may be installed in both horizontal and vertical lines with upward flow or in any intermediate position. They will operate satisfactorily in a declining plane (no more than 15°). Install check valves as far from pump discharge or line direction change as possible and at a minimum length of 5 times the pipe diameter.

Do not use for reciprocating air compressor service.

*Weighted average lead content ≤ 0.25%