

INSTALLATION, OPERATION AND MAINTENANCE MANUAL

Figure 920

**1" & 2" Compound Lever
Air Release Valves**

Drawing EAR-7003



234 Clay Avenue • Mars, PA 16046 USA
Telephone (724) 776-1020 • Fax (724) 776-1254
E-mail: info-ga@vag-group.com

Manual Number 920-IOM 022420



WARNING: Cancer and Reproductive Harm – www.Prop65Warnings.ca.gov

INSTALLATION, OPERATION INSTALLATION, OPERATION and MAINTENANCE

Figure 920 Air Release Valves

INTRODUCTION

This manual will provide the information to properly install, operate and maintain the valve to ensure a long service life. The Air Release Valve is ruggedly constructed to provide years of trouble-free operation with minimal maintenance.

These Air Release Valves are not intended for use with fluids containing suspended solids such as wastewater and sewage. The GA Industries Figure 925, 927 or 929 Air Release Valves are recommended for such applications.

CAUTION

The valve is NOT recommended for use with toxic fluids, fuels or fluids containing hazardous gases

CAUTION

The valve will not function if used at a pressure higher than the maximum working pressure indicated on the nameplate.

The Shop Order (SO) Number, Figure Number, size and pressure rating are stamped on a nameplate attached to the valve. Please refer to the SO number when ordering parts.

DESCRIPTION OF OPERATION

The Air Release Valve is designed to automatically vent air that has accumulated within the valve. These valves are usually installed at high points in the system where air tends to collect. The valve as shipped is "normally open" and will vent air through its orifice at the top of the valve. The float rises when water enters the valve and closes the orifice. Air from the system accumulates in the valve forcing the water level down until the float drops and opens the venting orifice. As air is released the water level rises lifting the float and re-closing the valve.

This sequence occurs as often as necessary to release air that has collected in the valve.

RECEIVING AND STORAGE

Inspect the valve upon receipt for damage during shipment. Carefully unload all valves to the ground without dropping.

The valves should remain in a clean, dry and weather protected area until installed. For long term storage (greater than 6 months) the rubber surfaces of the seat should be coated with a non-toxic lubricant such as "SuperLube" made by Synco Chemical. Do not expose the rubber parts to sunlight or ozone.

INSTALLATION

The Figure 920 is standard with NPT screwed connections. An optional flange pipeline connection is available on special order.

Consult the drawings of record to verify the configuration supplied and installed.

The valve must be installed in an upright vertical orientation, normally at a high point in the system.

If installed outdoors, below ground in a vault or in an unheated area, adequate freeze protection must be provided. Some discharge of water may occur during operation so the valve outlet should be piped to an adequate drain.

An isolating valve should be installed between the valve and the pipeline or system to facilitate maintenance.

Carefully screw threaded end valves onto pipe nipple using compatible thread sealant. Tighten valve using wrench flats. DO NOT OVERTIGHTEN.

Flat-faced flanged valves should be mated with flat-faced flanges and full-face gaskets. If ring gaskets are used the bolt material shall be ASTM A307 Grade B (or equivalent). Higher strength bolting should only be used with full-face gaskets.

Lower heavy valves over the mating flange using slings or chains around the valve body. Lubricate the bolts or studs and insert around flange. Lightly tighten bolts until gaps are eliminated. Torque bolts in an alternating pattern in graduated steps. If leakage occurs wait 24 hours and re-torque the bolts but do not compress the gasket more than 50% or exceed bolt maximum torque rating.

VALVE CONSTRUCTION

The standard Figure 920 Air Release Valve has a cast iron body, stainless steel float and linkage mechanism and a rubber seat. Optional materials such as ductile iron body can be provided for higher working pressures. Refer to the List of Materials submitted for the order if non-standard materials were provided.

Refer to Figure 1 for details of construction and parts location.

The body (1) has an inlet connection at the bottom where the valve attaches to the system and a smaller outlet connection at the top through which air leaves the valve.

WARNING

Removing the valve from the line or disassembling the valve while there is pressure in the valve body may result in injury or damage to the valve

PREVENTIVE MAINTENANCE

Figure 920 Air Release Valves require no scheduled lubrication, adjustment or preventive maintenance.

A periodic visual inspection should be performed to ensure the outlet piping is not obstructed and to verify there is no fluid leakage.

TESTING

Valve operation can be easily tested. Close the inlet isolation valve and remove or loosen the pipe plug nearest the inlet to drain the water from the valve. The float should drop as the water leaves the valve. NOTE: A ball or gate valve can be installed in place of the pipe plug to facilitate testing.

Replace or tighten the pipe plug and slowly open the inlet isolating valve. The valve should float closed and seat tightly.

TROUBLESHOOTING

- Valve Does Not Close / Fluid Leakage
Verify debris has not collected on the seat preventing tight closure

Verify rubber orifice button and/or orifice seating surfaces are not damaged

Verify float has buoyancy

Verify linkage mechanism operates freely without binding or sticking

- Valve Does Not Open
Verify debris in the valve is not preventing the float from freely falling when fluid is drained from valve

Verify linkage mechanism operates freely without binding or sticking

DISASSEMBLY

While small valves may be more easily serviced by removing it from the line, all valves can be serviced while the body remains connected to the pipeline. A skilled technician with proper tools should perform all work. No special tools are required.

First ensure there is no pressure within the valve. Remove the cover bolts and nuts (16 & 17) and lift off cover (2) with float and linkage attached. It may be necessary to pry the cover off. Be careful not to damage or lose o-ring (21).

Remove the two spring pins connecting the lever arm (5) and float arm (6) to the bracket (3). The float and linkage will be free from the cover.

Remove the spring pin connecting the pivot link (12) to the float arm (6) and remove the float screw (13) and lockwasher (9). Remove the hex nut (8) and lockwasher (9) and unscrew the orifice button (7) from the lever arm (5).

Remove the bracket screw (4) to remove the leverage bracket (3). Using a hex socket remove the orifice (20) from the cover.

Inspect all parts for wear and damage. Minor scratches and dents in the float are normal. Some floats may contain sand for added weight but if water is detected replace the float. Carefully clean the orifice of scale. Replace damaged parts.

REASSEMBLY

Clean all parts especially seating and sealing surfaces before reassembling valve. Worn parts should be replaced during re-assembly.

Apply Loctite® PST thread sealant to orifice (20) and thread into cover. Torque to maximum 22 ft-lbs.

Thread orifice button (7) all the way into lever arm (5) and install hex nut (8) and lockwasher (9) but do not tighten. Connect the lever arm (5) and float arm (6) to the bracket (3) using two spring pins.

Adjust the orifice button (7) so that the end of the lever arm (5) nearest the orifice button is about 1/16" (1.6mm) farther from the cover than the opposite end when the orifice button (7) is gently resting on the orifice (20). Secure by tightening hex nut (8)

Secure float (15) to pivot link (12) using screw (13) and lockwasher (9). Attach pivot link (12) to float arm (6) using spring pin. Verify free movement of linkage mechanism and that the orifice button (7) presses against the orifice (3) when the float is lifted and pulls away when falls.

Lubricate and place o-ring (21) in cover (2) and carefully place cover (2) on body (1) ensuring o-ring is retained. Install the cover bolts (16) and nuts (17) and tighten in an alternating pattern.

Carefully introduce pressure and check for leaks

REPLACEMENT PARTS

Genuine replacement parts are available from your local VAG/GA Industries representative or from the factory:

VAG USA, LLC
234 Clay Avenue
Mars, PA 16046 USA
Telephone: 724-776-1020
Fax: 724-776-1254
E-mail: quotes-ga@vag-group.co

Please have the nameplate data available when ordering parts.

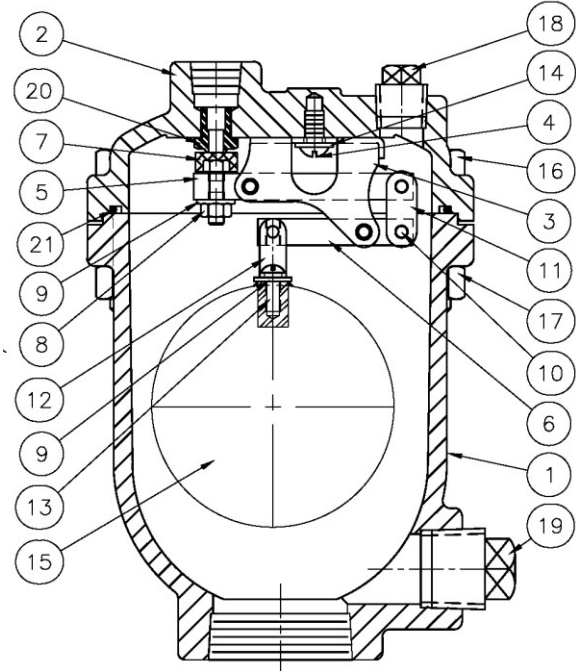

PARTS LIST

Item	Name	Material
1.	Body	Cast Iron
2.	Cover	Cast Iron
3.	Bracket	Stainless Steel
4.	Bracket Screw	Stainless Steel
5.	Lever Arm	Stainless Steel
6.	Float Arm	Stainless Steel
7.	Orifice Button	Stainless Steel
8.	Hex Nut	Stainless Steel
9.	Lock Washer	Stainless Steel
10.	Spring Pin	Stainless Steel
11.	Valve Link	Stainless Steel
12.	Pivot Link	Stainless Steel
13.	Float Screw	Stainless Steel
14.	Lock Washer	Stainless Steel
15.	Float Ball	Stainless Steel
16.	Cover Bolts	Steel
17.	Cover Nuts	Steel
18.	Pipe Plug	Malleable Iron
19.	Pipe Plug	Malleable Iron
20.	Orifice Button	Rubber & Stainless
21.	O-Ring	Rubber

WARRANTY

For a period of one year from the date of shipment, and provided payments for the Products have been made by Buyer to Seller, Seller warrants to Buyer that its Products: (i) substantially conform to Seller's published specifications and (ii) are free from defects in material or workmanship. Specific products may have a warranty period greater than one year. Any Services provided by Seller are warranted to be performed in a good and workmanlike manner. Should a warranted Product or any Services fail to conform to these warranties, Buyer must promptly notify Seller in writing. Seller will, at its discretion and at no charge to the Buyer: (i) repair the Product or Services; (ii) replace the Product or any Services; or (iii) offer a full refund of that portion of the purchase price allocable to the non-conforming Product or Services. Warranty repair or replacement by Seller shall not extend or renew the applicable warranty period. Buyer shall obtain Seller's agreement on the specifications of any tests it plans to conduct to determine whether a non-conformance exists. Buyer shall bear the costs of access for Seller's remedial warranty efforts (including removal and replacement of systems, structures or other parts of Buyer's facility), de-installation, decontamination and re-installation. THE FOREGOING WARRANTIES ARE IN LIEU OF ALL OTHER WARRANTIES, EXPRESS OR IMPLIED, INCLUDING BUT NOT LIMITED TO THE IMPLIED WARRANTIES OF MERCHANTABILITY AND FITNESS FOR A PARTICULAR PURPOSE. This warranty allocates the risks of Product failure between Seller and Buyer. This allocation is recognized by both parties and is reflected in the price of the goods. Buyer acknowledges that it has read VAG USA, LLC's Terms and Conditions of Sale, understands it, and agrees to and is bound by its terms.

WHAT IS NOT COVERED BY WARRANTY

No representative of Seller has authority to waive, alter, vary or add to the terms hereof without prior written approval of an officer of Seller. Seller's warranty does not apply to: (i) dynamic vibrations imposed by the drive system in which such Products are installed unless the nature of such vibrations has been defined and accepted in writing by Company as a condition of operation; (ii) improper or unauthorized repair, installation or maintenance of the Products by a party other than Seller; (iii) use for purposes other than those for which designed, or other abuse, negligence, misuse, or normal wear and tear; (iv) unauthorized attachments, modifications or disassembly; (v) damage during shipping; or (vi) Products purchased from unauthorized distributors, resellers or internet sites. Buyer's care in selection, adequate testing at time of installation and proper installation, operation and maintenance of all Products is required for adequate performance.

LIMITATIONS OF LIABILITY

NOTWITHSTANDING ANY PROVISION OF THIS CONTRACT OR THE LAW, IT IS EXPRESSLY AGREED THAT SELLER'S TOTAL LIABILITY FOR ANY DAMAGES, COSTS OR EXPENSES ARISING OUT OF OR RELATED TO THIS CONTRACT OR ITS PRODUCTS OR SERVICES, WHETHER BASED IN CONTRACT, WARRANTY, INDEMNITY, TORT/EXTRA-CONTRACTUAL LIABILITY (INCLUDING NEGLIGENCE), STRICT LIABILITY OR OTHERWISE IS LIMITED TO THE REPAIR OR REPLACEMENT OF THE PRODUCT OR SERVICES OR, AT SELLER'S OPTION, A RETURN OF AN AMOUNT THAT SHALL NOT EXCEED THE PURCHASE PRICE. UNDER NO CIRCUMSTANCES WILL SELLER, IT'S OFFICERS, DIRECTORS, EMPLOYEES OR ASSIGNS BE LIABLE FOR ANY OTHER REMEDY, LOSS, COST, DAMAGE OR EXPENSE WHETHER DIRECT OR INDIRECT. IN NO EVENT WHATSOEVER SHALL SELLER BE LIABLE FOR ANY CONSEQUENTIAL, LIQUIDATE, EXEMPLARY OR PUNITIVE DAMAGES, INCLUDING BUT NOT LIMITED TO, LOSS OF USE, INCOME, PROFIT, OR PRODUCTION; INCREASED COST OF OPERATION, SPOILAGE OR DAMAGE TO MATERIAL, OR CHANGE OUT COSTS. BUYER SHALL INDEMNIFY, DEFEND AND HOLD SELLER HARMLESS FROM ANY LOSS, COST, EXPENSE, DAMAGE, OR CAUSE OF ACTION TO OR BY A THIRD PARTY THAT EXCEEDS THESE LIMITATIONS OF LIABILITY.