



Air Conditioning & Heating

# CPH COMMERCIAL

## 3- TO 6-TON PACKAGED HEAT PUMP

### 13 SEER / UP TO 11.3 EER & 7.7 HSPF

**COOLING CAPACITY: 35,000 — 70,000 BTU/H**

**HEATING CAPACITY: 34,600 — 70,000 BTU/H**



#### Standard Features

- R-410A chlorine-free refrigerant
- High-efficiency scroll compressor
- Copper tube / aluminum fin coils
- High- and low-pressure switches
- Refrigerant accumulator
- Contactor with lugs
- High-capacity, steel-cased filter drier
- Heater kits with single-point entry
- 24-volt terminal strip
- Convertible
- Easy to service
- Built-in filter rack with standard 2" filters
- Bottom utility entry
- AHRI Certified; ETL Listed

#### Cabinet Features

- Heavy-gauge, galvanized-steel cabinet with UV-resistant powder-paint finish
- Full Perimeter Rail

## SINGLE PHASE & THREE PHASE

#### Contents

Nomenclature .....	2
Product Specifications .....	3
Airflow Data .....	7
Expanded Heating Data .....	17
Heat Kit Electrical Data .....	13
Expanded Cooling Data .....	18
Dimensions .....	26
Wiring Diagrams .....	30
Accessories .....	36



\* Complete warranty details available from your local dealer or at [www.goodmanmfg.com](http://www.goodmanmfg.com).



NOMENCLATURE

	C	P	H	060	015	3	B	*	*	*	A	*	
	1	2	3	4,5,6	7,8,9	10	11	12	13	14	15	16	
												<b>Revision Levels</b>	
												Major & Minor	
<b>Brand</b>												<b>Factory-Installed Options</b>	
C Commercial												X No Options	
<b>Configuration</b>												A Non-powered convenience outlet	
P Packaged Unit												B Powered convenience outlet	
<b>Application</b>												C Low-ambient kit	
C Cooling												D Return air smoke detector	
G Gas Heat												E Supply air smoke detector	
H Heat Pump												F Non-powered convenience outlet; Low-ambient kit	
<b>Nominal Gross Cooling Capacity</b>												G Non-powered convenience outlet; Return air smoke detector	
036 3 Tons 102 8½ Tons												H Non-powered convenience outlet; Supply air smoke detector	
048 4 Tons 120 10 Tons												J Non-powered convenience outlet; Return & Supply air smoke detectors	
060 5 Tons 150 12½ tons												K Non-powered convenience outlet; Low-ambient kit; Supply air smoke detector	
072 6 Tons 180 & 181 15 Tons												L Non-powered convenience outlet; Low-ambient kit	
090 7½ Tons 240 20 Tons												M Powered convenience outlet; Return & Supply air smoke detectors	
<b>Nominal Heating Capacity</b>												N Powered convenience outlet; Return air smoke detector	
<b>CPG</b>												O Powered convenience outlet; Return & Supply air smoke detectors	
<b>CPC/CPH (Factory-Installed Electric Heat)</b>												P Powered convenience outlet; Supply air smoke detector	
045 45,000 BTU/h XXX No Heat												Q Powered convenience outlet; Low-ambient kit; Return air smoke detector	
090 90,000 BTU/h 010 10 kW 030 30 kW												R Powered convenience outlet; Low-ambient kit; Supply air smoke detector	
115 115,000 BTU/h 015 15 kW 031 30 kW												T Powered convenience outlet; Low-ambient kit; Return & Supply air smoke detectors	
140 140,000 BTU/h 016 15 kW 045 45 kW												U Non-powered convenience outlet; Low-ambient kit; Return air smoke detector	
210 210,000 BTU/h 018 18 kW 046 45 kW												V Low-ambient kit; Return air smoke detector	
350 350,000 BTU/h 020 20 kW 060 60 kW												W Low-ambient kit; Supply air smoke detector	
400 400,000 BTU/h 025 25 kW 075 75 kW												Y Low-ambient kit; Return & Supply air smoke detectors	
<b>Voltage</b>												Z Return & Supply air smoke detectors	
1 208-230/1/60 4 460/3/60													
3 208-230/3/60 7 575/3/60													
<b>Supply Fan/Drive Type/Motor</b>												<b>Factory-Installed Options</b>	
B Belt Drive												X Standard Aluminized Heat Exchanger	
D Direct Drive												A Condenser Coil Hail Guard	
H High-Static Belt Drive (Factory-Installed)												B Condenser Coil Hail Guard	
<b>Factory-Installed Options</b>												C Condenser Coil Hail Guard	
X No Options												D Treated Condenser Coil (UltraGold)	
A Downflow Economizer												E Condenser Coil Hail Guard	
H Disconnect Switch (non-fused)												F Stainless-Steel Heat Exchanger	
J Downflow Economizer; Disconnect Switch (non-fused)												G Condenser Coil Hail Guard	
												H Treated Condenser Coil (UltraGold)	
												I Stainless-Steel Heat Exchanger	
												J Treated Condenser Coil (UltraGold)	
												K Stainless-Steel Heat Exchanger	
												L Treated Condenser Coil (UltraGold)	
												M Stainless-Steel Heat Exchanger	
												N Treated Condenser Coil (UltraGold)	
												O Stainless-Steel Heat Exchanger	
												P Treated Condenser Coil (UltraGold)	
												Q Stainless-Steel Heat Exchanger	
												R Treated Condenser Coil (UltraGold)	
												S Stainless-Steel Heat Exchanger	
												T Treated Condenser Coil (UltraGold)	
												U Stainless-Steel Heat Exchanger	

Note: Not all options available for all products.

**Factory-Installed Options**

- Condenser Hail Guards: Louvered metal guards help protect the condenser coil from damage from hail and debris. Available as a factory-installed option on 3- to 12½-ton units. Hail guards are standard on 15- and 20-ton units.
- Stainless-Steel Heat Exchanger (CPG units only): A tubular heat exchanger made of 409-type stainless steel is installed in the unit.
- Ultra-Gold Condenser Coil: Offers increased corrosion resistance of the condenser coil. Not available for 15- & 20-ton units.
- Low-Ambient Kit: Allows for cooling operation at lower outdoor temperatures. On the 3- to 6-ton units, cooling operation is extended from 60°F ambient temperature to 35°F outside air temperature. On 7½- to 20-ton units, cooling operation is extended from 35°F ambient temperature to 0°F outside air temperature.
- Economizers (Downflow): Based on air conditions, can provide outside air to cool the space.
- High Static Kits: Provides airflow in higher static applications.
- Electric Heat Kits (CPC and CPH units only): Available in all voltage options.
- Non-powered Convenience Outlet: A 120V, 15A, GFCI outlet makes it easier for technicians to service the unit once an electrician runs power to the outlet.
- Powered Convenience Outlet: A 120V, 15A, GFCI outlet powered with a transformer built into the unit.
- Disconnect Switch (non-fused): A disconnect switch is installed in the unit and factory wiring will be complete from the switch to the unit. Please note that for air conditioning (CPC units) and heat pump models (CPH units), the appropriate electric heat kit must be ordered to be factory-installed along with the disconnect switch (non-fused) when it is ordered. Please note that for models with a powered convenience outlet option and a disconnect switch (non-fused) option, the power to the powered convenience outlet will be shut off when the disconnect switch (non-fused) is in the off position.
- Return Air and/or Supply Air Smoke Detectors: Return air and/or supply air smoke detectors are installed in the unit.

PRODUCT SPECIFICATIONS — 3 TONS

	CPH036 ***1D***B*	CPH036 ***3D***B*	CPH036 ***3B***B*	CPH036 ***4B***B*	CPH036 ***7B***B*
<b>COOLING CAPACITY</b>					
Total BTU/h	35,000	35,000	35,000	35,000	35,000
Sensible BTU/h	25,460	25,460	25,460	25,460	25,460
SEER / EER	13 / 11	13 / 11	13 / 11	13 / 11	13 / 11
Decibels	78	78	78	78	78
AHRI Reference #s	4385108	4385109	4385109	4385110	4397610
<b>HEATING CAPACITY</b>					
BTU/h / COP (47° F)	34,600 / 3.5	34,600 / 3.5	34,600 / 3.5	34,600 / 3.5	34,600 / 3.62
BTU/h / COP (17° F)	19,000 / 2.2	19,000 / 2.2	19,000 / 2.2	19,000 / 2.2	19,000 / 2.2
HSPF	7.7	7.7	7.7	7.7	7.7
<b>EVAPORATOR MOTOR / COIL</b>					
Motor Type	Direct Drive	Direct Drive	Belt Drive	Belt Drive	Belt Drive
# of Wheels (D x W)	1 (10" x 9")	1 (10" x 9")	1 (11" x 10")	1 (11" x 10")	1 (11" x 10")
Indoor Nominal CFM	1,200	1,200	1,200	1,200	1,200
Motor Speed Tap (Cooling)	Low Speed	Low Speed	---	---	---
Indoor Motor FLA (Cooling)	2.50	2.50	3.8	1.9	2.3
Horsepower - RPM	¼ - 890	¼ - 890	1.0 - 1725	1.0 - 1725	1.5 - 1725
Piston Size (Cooling)	0.068	0.068	0.068	0.068	0.068
Filter Size (Qty)	(1) 24" x 24" x 2"	(1) 24" x 24" x 2"	(1) 24" x 24" x 2"	(1) 24" x 24" x 2"	(1) 24" x 24" x 2"
Drain Size (NPT)	¾"	¾"	¾"	¾"	¾"
R-410A Refrigerant Charge (oz.)	105	105	105	105	135
Evaporator Coil Face Area (ft²)	5.4	5.4	5.4	5.4	5.4
Rows Deep / Fins per Inch	3 / 16	3 / 16	3 / 16	3 / 16	3 / 16
<b>BELT DRIVE EVAP FAN DATA</b>					
# of Wheels (D x W)	1 (10" x 9")	1 (10" x 9")	1 (11" x 10")	1 (11" x 10")	1 (11" x 10")
Motor Sheave	---	---	1VL40 x ¾"	1VL40 x ¾"	1VL40 x ¾"
Blower Sheave / Belt	---	---	AK69 x 1 / AX52	AK69 x 1 / AX52	AK69 x 1 / AX52
<b>CONDENSER FAN / COIL</b>					
Quantity of Condenser Fan Motors	1	1	1	1	1
Horsepower - RPM	¼ / 1,090	¼ / 1,090	¼ / 1,090	¼ - 890	¼ - 1,075
Fan Diameter / # Fan Blades	22 / 4	22 / 4	22 / 4	22 / 4	22 / 4
Outdoor Nominal CFM	3,800	3,800	3,800	3,800	3,800
Face Area (ft²)	17.0	17.0	17.0	17.0	13.0
Rows Deep / Fins per Inch	1 / 24	1 / 24	1 / 24	1 / 24	2 / 16
Piston Size (Heating)	0.055	0.055	0.055	0.055	0.053
<b>COMPRESSOR</b>					
Quantity / Type	1 / Scroll	1 / Scroll	1 / Scroll	1 / Scroll	1 / Scroll
Stage	Single	Single	Single	Single	Single
Compressor RLA / LRA	16.7 / 79.0	10.5 / 73.0	10.5 / 73.0	5.8 / 38.0	3.8 / 36.5
<b>ELECTRICAL DATA</b>					
Voltage - Phase - Frequency	208/230-1-60	208/230-3-60	208/230-3-60	460-3-60	575-3-60
Indoor Blower HP / FLA	¼ / 2.5	¼ / 2.5	1.0 / 3.8	1.0 / 1.9	1.5 / 2.3
Outdoor Fan HP / FLA	¼ / 1.4	¼ / 1.4	¼ / 1.4	¼ / 0.8	¼ / 0.6
Total Unit Amps	20.57	14.35	15.65	8.47	6.68
Min. Circuit Ampacity <sup>1</sup>	25	17	18	10	8
Max. Overcurrent Protection (amps) <sup>2</sup>	40	25	25	15	10
Power Supply Conduit Hole	1.125"	1.125"	1.125"	1.125"	1.125"
Low Voltage Conduit Hole	½"	½"	½"	½"	½"
<b>OPERATING WEIGHT (LBS)</b>	580	580	580	580	580
<b>SHIP WEIGHT (LBS)</b>	605	605	605	605	605

<sup>1</sup> Wire size should be determined in accordance with National Electrical Codes. Extensive wire runs will require larger wire sizes.

<sup>2</sup> May use fuses or HACR-type circuit breakers of the same size as noted.

Note: Always check the S&R plate for electrical data on the unit being installed.

PRODUCT SPECIFICATIONS — 4 TONS

	CPH048 ***1D***B*	CPH048 ***3D***B*	CPH048 ***3B***B*	CPH048 ***4B***B*	CPH048 ***7B***B*
<b>COOLING CAPACITY</b>					
Total BTU/h	46,000	46,000	46,000	46,000	46,000
Sensible BTU/h	34,500	34,500	34,500	34,500	34,500
SEER / EER	13 / 11.3	13 / 11.3	13 / 11.3	13 / 11.3	13 / 11.3
Decibels	78	78	78	78	78
AHRI Reference #s	4385111	4385112	4385112	4385113	4397611
<b>HEATING CAPACITY</b>					
BTU/h / COP (47° F)	45,000 / 3.5	45,000 / 3.5	45,000 / 3.5	45,000 / 3.5	45,000 / 3.5
BTU/h / COP (17° F)	24,800 / 2.2	24,800 / 2.2	24,800 / 2.2	24,800 / 2.2	24,800 / 2.2
HSPF	7.7	7.7	7.7	7.7	7.7
<b>EVAPORATOR MOTOR / COIL</b>					
Motor Type	Direct Drive	Direct Drive	Belt Drive	Belt Drive	Belt Drive
Indoor Nominal CFM	1,600	1,600	1,600	1,600	1,600
Motor Speed Tap (Cooling)	Medium	Medium	---	---	---
Indoor Motor FLA (Cooling)	2.87	2.87	3.8	1.9	2.3
Horsepower - RPM	½ - 1,000	½ - 1,000	1.0 - 1,725	1.0 - 1,725	1.5 - 1,725
Piston Size (Cooling)	0.076	0.076	0.076	0.076	0.076
Filter Size (#)	14 x 20 x 2 (4)	14 x 20 x 2 (4)	14 x 20 x 2 (4)	14 x 20 x 2 (4)	14 x 20 x 2 (4)
Drain Size (NPT)	¾"	¾"	¾"	¾"	¾"
R-410A Refrigerant Charge (oz.)	170	170	170	170	170
Evaporator Coil Face Area (ft²)	7.8	7.8	7.8	7.8	7.8
Rows Deep / Fins per Inch	4 / 16	4 / 16	4 / 16	4 / 16	4 / 16
<b>BELT DRIVE EVAP FAN DATA</b>					
# of Wheels (D x W)	1 (10" x 9")	1 (10" x 9")	1 (11" x 10")	1 (11" x 10")	1 (11" x 10")
Motor Sheave	---	---	VL44 x ¾	VL44 x ¾	VL44 x ¾
Blower Sheave / Belt	---	---	AK66 x 1 / AX52	AK66 x 1 / AX52	AK66 x 1 / AX52
<b>CONDENSER FAN / COIL</b>					
Quantity of condenser Fan Motors	1	1	1	1	1
Horsepower - RPM	¼ / 1,090	¼ / 1,090	¼ / 1,090	¼ - 890	¼ - 1,075
Fan Diameter / # Fan Blades	22 / 4	22 / 4	22 / 4	22 / 4	22 / 4
Outdoor Nominal CFM	3,800	3,800	3,800	3,800	3,800
Face Area (ft²)	17	17	17	17	17
Rows Deep / Fins per Inch	2 / 18	2 / 18	2 / 18	2 / 18	2 / 18
Piston Size (Heating)	0.057	0.057	0.057	0.057	0.057
<b>COMPRESSOR</b>					
Quantity / Type	1 / Scroll	1 / Scroll	1 / Scroll	1 / Scroll	1 / Scroll
Stage	Single	Single	Single	Single	Single
Compressor RLA / LRA	20 / 109	13.1 / 83.1	13.1 / 83.1	6.1 / 41	4.4 / 33
<b>ELECTRICAL DATA</b>					
Voltage - Phase - Frequency	208/230-1-60	208/230-3-60	208/230-3-60	460-3-60	575-3-60
Outdoor Fan FLA	1.40	1.40	1.40	0.80	0.60
Total Unit Amps	24.1	17.4	18.3	8.8	7.3
Min. Circuit Ampacity <sup>1</sup>	29	21	22	10	8
Max. Overcurrent Protection (amps) <sup>2</sup>	45	30	30	15	10
Power Supply Conduit Hole	1.125"	1.125"	1.125"	1.125"	1.125"
Low Voltage Conduit Hole	½"	½"	½"	½"	½"
<b>OPERATING WEIGHT (LBS)</b>	585	585	585	585	585
<b>SHIP WEIGHT (LBS)</b>	610	610	610	610	610

<sup>1</sup> Wire size should be determined in accordance with National Electrical Codes. Extensive wire runs will require larger wire sizes.

<sup>2</sup> May use fuses or HACR-type circuit breakers of the same size as noted.

Note: Always check the S&R plate for electrical data on the unit being installed.

PRODUCT SPECIFICATIONS — 5 TONS

	CPH060 ***1D***B*	CPH060 ***3D***B*	CPH060 ***3B***B*	CPH060 ***4B***B*	CPH060 ***7B***B*
<b>COOLING CAPACITY</b>					
Total BTU/h	59,500	59,500	59,500	59,500	59,500
Sensible BTU/h	43,200	43,200	43,200	43,200	43,200
SEER / EER	13 / 11.0	13 / 11.0	13 / 11.0	13 / 11.0	13 / 11.0
Decibels	78	78	78	78	78
AHRI Reference #s	4385114	4385115	4385115	4385116	4397612
<b>HEATING CAPACITY</b>					
BTU/h / COP (47° F)	57,000 / 3.5	57,000 / 3.5	57,000 / 3.5	57,000 / 3.5	57,000 / 3.5
BTU/h / COP (17° F)	32,000 / 2.2	32,000 / 2.2	32,000 / 2.2	32,000 / 2.2	32,000 / 2.2
HSPF	7.7	7.7	7.7	7.7	7.7
<b>EVAPORATOR MOTOR/ COIL</b>					
Motor Type	Direct	Direct	Belt	Belt	Belt
Indoor Nominal CFM	1,950	1,950	1,950	1,950	1,950
Piston Size (Cooling)	0.082	0.082	0.082	0.082	0.082
Filter Size (#)	14 x 20 x 2 (4)	14 x 20 x 2 (4)	14 x 20 x 2 (4)	14 x 20 x 2 (4)	14 x 20 x 2 (4)
Drain Size (NPT)	¾"	¾"	¾"	¾"	¾"
R-410A Refrigerant Charge (oz.)	170	170	170	170	170
Face Area (ft²)	7.8	7.8	7.8	7.8	7.8
Rows Deep / Fins per Inch	4 / 16	4 / 16	4 / 16	4 / 16	4 / 16
Tube Diameter - Material	5/16 - Copper	5/16 - Copper	5/16 - Copper	5/16 - Copper	5/16 - Copper
<b>BELT DRIVE EVAP FAN DATA</b>					
# of Wheels (D x W)	---	---	1 (11" x 10")	1 (11" x 10")	1 (11" x 10")
Motor Sheave	---	---	VL44 x ¾"	VL44 x ¾"	VL44 x ¾"
Blower Sheave / Belt	---	---	AK61 x 1 / AX52	AK61 x 1 / AX52	AK61 x 1 / AX52
<b>CONDENSER FAN / COIL</b>					
Horsepower / RPM	¼ / 1,090	¼ / 1,090	¼ / 1,090	¼ / 1,090	¼ / 1,075
Fan Diameter/ # Fan Blades	22 / 4	22 / 4	22 / 4	22 / 4	22 / 4
Outdoor Nominal CFM	3,800	3,800	3,800	3,800	3,800
Face Area (ft²)	17	17	17	17	17
Rows Deep / Fins per Inch	2 / 18	2 / 18	2 / 18	2 / 18	2 / 18
Tube Diameter - Material	5/16 - Copper	5/16 - Copper	5/16 - Copper	5/16 - Copper	5/16 - Copper
Piston Size (Heating)	0.064	0.064	0.064	0.064	0.064
<b>COMPRESSOR</b>					
Quantity / Type	1 / Scroll	1 / Scroll	1 / Scroll	1 / Scroll	1 / Scroll
Stage	Single	Single	Single	Single	Single
Compressor RLA / LRA	26.4 / 134	16 / 110	16 / 110	7.8 / 52	5.7 / 38.9
<b>ELECTRICAL DATA</b>					
Voltage - Phase - Frequency	208/230-1-60	208/230-3-60	208/230-3-60	460-3-60	575-3-60
Indoor Blower HP / FLA	1.0 / 7.6	1.0 / 7.6	1.0 / 3.8	1.0 / 1.9	1.5 / 2.3
Indoor Blower LRA	----	----	24	12	12
Outdoor Fan HP / FLA	¼ / 1.40	¼ / 1.40	¼ / 1.40	¼ / 0.80	¼ / 0.60
Total Unit Amps	35.4	25	21.2	10.5	8.6
Min. Circuit Ampacity <sup>1</sup>	42	29	25	12	10
Max. Overcurrent Protection (amps) <sup>2</sup>	60	45	40	20	15
Power Supply Conduit Hole	1.125"	1.125"	1.125"	1.125"	1.125"
Low Voltage Conduit Hole	½"	½"	½"	½"	½"
<b>OPERATING WEIGHT (LBS)</b>	590	590	590	590	590
<b>SHIP WEIGHT (LBS)</b>	615	615	615	615	615

<sup>1</sup> Wire size should be determined in accordance with National Electrical Codes. Extensive wire runs will require larger wire sizes.

<sup>2</sup> May use fuses or HACR-type circuit breakers of the same size as noted.

Note: Always check the S&R plate for electrical data on the unit being installed.

PRODUCT SPECIFICATIONS — 6 TONS

	CPH072 ***3B***B*	CPH072 ***4B***B*	CPH072 ***7B***B*
<b>COOLING CAPACITY</b>			
Total BTU/h	70,000	70,000	70,000
Sensible BTU/h	50,410	50,410	50,410
EER / IEER	11.1 / 11.2	11.1 / 11.2	11.1 / 11.2
Decibels	78.0	78.0	78.0
AHRI Number	5104780	5104780	5104780
<b>HEATING CAPACITY</b>			
BTU/h (47° F)	70,000	70,000	70,000
COP (47°F)	3.6	3.6	3.6
BTU/h (17° F)	39,000	39,000	39,000
COP (17°F)	2.3	2.3	2.3
<b>EVAPORATOR MOTOR / COIL</b>			
Motor Type	Belt Drive	Belt Drive	Belt Drive
# of Wheels (D x W)	1 (11" x 10")	1 (11" x 10")	1 (11" x 10")
Indoor Nominal CFM	2,400	2,400	2,400
Indoor Motor FLA (Cooling)	5.0	2.5	2.3
Horsepower - RPM	1.5-1,725	1.5-1,725	1.5-1,725
Piston Size (Cooling)	0.094	0.094	0.094
Filter Size (Qty)	(4) 16" x 20" x 2"	(4) 16" x 20" x 2"	(4) 16" x 20" x 2"
Drain Size (NPT)	¾"	¾"	¾"
R-410A Refrigerant Charge (oz.)	233.0	233.0	233.0
Evaporator Coil Face Area (ft²)	8.9	8.9	8.9
Rows Deep/ Fins per Inch	4/ 16	4/ 16	4/ 16
Motor Sheave	VL44 x 7/8	VL44 x 7/8	VL44 x 7/8
Blower Sheave / Belt	AK59x1 / AX52	AK59x1 / AX52	AK59x1 / AX52
<b>CONDENSER FAN / COIL</b>			
Quantity of Condenser Fan Motors	1	1	1
Horsepower - RPM	⅓ - 1,075	⅓ - 1,075	⅓ - 1,075
Fan Diameter/ # Fan Blades	22/ 4	22/ 4	22/ 4
Outdoor Nominal CFM	4,300	4,300	4,300
Face Area (ft²)	18.7	18.7	18.7
Rows Deep/ Fins per Inch	2/ 20	2/ 20	2/ 20
Piston Size (Heating)	0.080	0.080	0.080
<b>COMPRESSOR</b>			
Quantity / Stage	1 / Single	1 / Single	1 / Single
Type	Scroll	Scroll	Scroll
Compressor RLA / LRA	19/123.0	9.7/62.0	7.4/50.0
<b>ELECTRICAL DATA</b>			
Voltage/ Phase/ Frequency	208-230/ 3/ 60	460/ 3/ 60	575/ 3/ 60
Belt-Driven Standard Max Static	1.0	1.0	1.0
Outdoor Fan FLA	1.90	1.20	0.90
Total Unit Amps	25.9	13.4	10.6
Min. Circuit Ampacity <sup>1</sup>	31	16	12
Max. Overcurrent Protection (amps) <sup>2</sup>	45	25	15
Entrance Power Supply	1.125"	1.125"	1.125"
Entrance Control Voltage	½"	½"	½"
<b>OPERATING WEIGHT (LBS)</b>	650	650	650
<b>SHIP WEIGHT (LBS)</b>	675	675	675

<sup>1</sup> Wire size should be determined in accordance with National Electrical Codes. Extensive wire runs will require larger wire sizes.

<sup>2</sup> May use fuses or HACR-type circuit breakers of the same size as noted.

Note: Always check the S&R plate for electrical data on the unit being installed.

**AIRFLOW DATA — CPH036**

**STANDARD BELT DRIVE — HORIZONTAL**

ESP (" W.C.)	TURNS OPEN											
	0		1		2		3		4		5	
	CFM	BHP	CFM	BHP	CFM	BHP	CFM	BHP	CFM	BHP	CFM	BHP
0.2									1658	0.35	1489	0.28
0.4							1560	0.36	1339	0.28	1129	0.21
0.6			1682	0.47	1436	0.36	1196	0.27	949	0.19		
0.8	1581	0.50	1354	0.38	1096	0.28	828	0.18				
1.0	1266	0.39	994	0.28	756	0.19						
1.2	923	0.28										

**HIGH-STATIC BELT DRIVE — HORIZONTAL**

ESP (" W.C.)	TURNS OPEN											
	0		1		2		3		4		5	
	CFM	BHP	CFM	BHP	CFM	BHP	CFM	BHP	CFM	BHP	CFM	BHP
0.6									1742	0.50	1431	0.36
0.8							1626	0.52	1357	0.39	1078	0.27
1.0					1611	0.56	1315	0.42	1011	0.28		
1.2			1605	0.62	1299	0.46	976	0.31				
1.4	1605	0.68	1281	0.51	959	0.35						
1.6	1281	0.57	981	0.41								
1.8	981	0.47										

**STANDARD BELT DRIVE — DOWN SHOT**

ESP (" W.C.)	TURNS OPEN											
	0		1		2		3		4		5	
	CFM	BHP	CFM	BHP	CFM	BHP	CFM	BHP	CFM	BHP	CFM	BHP
0.2									1424	0.30	1239	0.23
0.4					1520	0.39	1292	0.29	1073	0.22	779	0.14
0.6			1439	0.40	1192	0.30	944	0.21	619	0.12		
0.8	1350	0.42	1101	0.31	864	0.22						
1.0	1028	0.31	729	0.21								
1.2	675	0.20										

**HIGH-STATIC BELT DRIVE — DOWN SHOT**

ESP (" W.C.)	TURNS OPEN											
	0		1		2		3		4		5	
	CFM	BHP	CFM	BHP	CFM	BHP	CFM	BHP	CFM	BHP	CFM	BHP
0.6							1692	0.54	1449	0.41	1173	0.29
0.8					1678	0.58	1397	0.44	1107	0.31	854	0.21
1.0			1681	0.65	1381	0.49	1078	0.34	794	0.22		
1.2	1681	0.71	1362	0.54	1062	0.39						
1.4	1362	0.60	1066	0.44								
1.6	1066	0.50	789	0.34								
1.8	789	0.40										

## AIRFLOW DATA — CPH036 (CONT.)

### STANDARD DIRECT DRIVE — HORIZONTAL

CFM	STATIC	AMPS	WATTS	RPM	SPEED TAP
1296	0.1	1.67	356	764	Low
1245	0.2	1.60	334	830	
1174	0.3	1.56	325	861	
1103	0.4	1.52	316	891	
1013	0.5	1.46	300	935	
1502	0.1	2.10	456	836	
1449	0.2	2.06	444	864	
1396	0.3	2.02	432	891	
1335	0.4	1.97	418	916	
1273	0.5	1.91	404	940	
1153	0.6	1.83	380	973	
996	0.7	1.71	346	1017	
1516	0.2	2.36	506	940	High
1454	0.3	2.31	496	960	
1392	0.4	2.26	486	979	
1273	0.5	2.17	458	1006	
1183	0.6	2.09	441	1023	
1092	0.7	2.02	424	1039	
920	0.8	1.90	390	1067	

### STANDARD DIRECT DRIVE — DOWN SHOT

CFM	STATIC	AMPS	WATTS	RPM	SPEED TAP
1287	0.1	1.66	350	770	Low
1233	0.2	1.63	342	815	
1176	0.3	1.59	332	858	
1107	0.4	1.55	320	891	
1044	0.5	1.51	312	924	
965	0.6	1.45	296	957	
1476	0.1	2.08	446	866	
1421	0.2	2.03	432	885	
1334	0.3	1.96	414	918	
1255	0.4	1.90	396	945	
1180	0.5	1.84	386	971	
1085	0.6	1.78	368	990	
964	0.7	1.70	344	1023	
1455	0.3	2.31	490	962	High
1367	0.4	2.25	476	984	
1277	0.5	2.16	454	1006	
1180	0.6	2.09	438	1025	
1080	0.7	2.02	418	1039	
922	0.8	1.90	386	1067	

SEE NOTES BELOW

## AIRFLOW DATA — CPH048

### STANDARD DIRECT DRIVE — HORIZONTAL

CFM	STATIC	AMPS	WATTS	RPM	SPEED TAP
1622	0.1	2.54	539	809	Low
1558	0.2	2.43	517	852	
1494	0.3	2.32	495	895	
1410	0.4	2.21	471	924	
1326	0.5	2.10	447	953	
1861	0.1	3.11	670	886	
1733	0.2	2.78	606	918	
1639	0.3	2.64	568	960	
1564	0.4	2.51	542	984	
1434	0.5	2.35	508	1017	
1320	0.6	2.25	482	1039	
1156	0.7	2.08	446	1067	
1984	0.1	3.34	734	949	High
1883	0.2	3.18	694	977	
1770	0.3	3.03	654	1001	
1656	0.4	2.87	620	1027	
1540	0.5	2.76	590	1044	
1415	0.6	2.62	558	1061	

### STANDARD DIRECT DRIVE — DOWN SHOT

CFM	STATIC	AMPS	WATTS	RPM	SPEED TAP
1602	0.1	2.48	528	835	Low
1538	0.2	2.37	506	878	
1474	0.3	2.26	484	921	
1390	0.4	2.15	460	950	
1306	0.5	2.04	436	979	
1805	0.1	2.84	620	935	
1704	0.2	2.71	590	967	
1625	0.3	2.59	558	990	
1549	0.4	2.47	540	1012	
1437	0.5	2.38	516	1030	
1301	0.6	2.23	480	1050	
1158	0.7	2.09	444	1072	
1971	0.1	3.22	706	968	High
1828	0.2	3.03	664	998	
1744	0.3	2.94	632	1017	
1628	0.4	2.80	606	1034	
1510	0.5	2.69	582	1050	
1402	0.6	2.57	552	1067	

**NOTES**

- Assumes dry coil with filter in place; SCFM correction for wet coil = 4%
- Five-ton models are shipped from the factory with speed tap set on T4.



**AIRFLOW DATA — CPH048 (CONT.)**

**STANDARD BELT DRIVE — HORIZONTAL**

ESP (" W.C.)	TURNS OPEN											
	0		1		2		3		4		5	
	CFM	BHP	CFM	BHP	CFM	BHP	CFM	BHP	CFM	BHP	CFM	BHP
0.2									1943	0.52	1714	0.40
0.4					2187	0.72	1876	0.55	1566	0.40	1270	0.26
0.6			2044	0.72	1761	0.56	1444	0.40	1136	0.26		
0.8	1947	0.74	1704	0.59	1335	0.40						
1.0	1598	0.60	1275	0.36								
1.2	1208	0.45										

**HIGH-STATIC BELT DRIVE — HORIZONTAL**

ESP (" W.C.)	TURNS OPEN											
	0		1		2		3		4		5	
	CFM	BHP	CFM	BHP	CFM	BHP	CFM	BHP	CFM	BHP	CFM	BHP
0.6									2056	0.72	1721	0.54
0.8							1996	0.77	1662	0.57	1328	0.40
1.0					1924	0.79	1603	0.61	1270	0.43		
1.2			1952	0.88	1559	0.64	1210	0.44				
1.4	1888	0.92	1543	0.70	1195	0.49						
1.6	1557	0.77	1180	0.54								
1.8	1192	0.60										

**STANDARD BELT DRIVE — DOWN SHOT**

ESP (" W.C.)	TURNS OPEN											
	0		1		2		3		4		5	
	CFM	BHP	CFM	BHP	CFM	BHP	CFM	BHP	CFM	BHP	CFM	BHP
0.2							2129	0.64	1795	0.47	1550	0.35
0.4					1994	0.65	1701	0.49	1433	0.36	1163	0.22
0.6			1905	0.67	1606	0.50	1326	0.36	1025	0.22		
0.8	1808	0.69	1565	0.54	1216	0.36						
1.0	1473	0.55	1137	0.32								
1.2	1103	0.41										

**HIGH STATIC BELT DRIVE — DOWN SHOT**

ESP (" W.C.)	TURNS OPEN											
	0		1		2		3		4		5	
	CFM	BHP	CFM	BHP	CFM	BHP	CFM	BHP	CFM	BHP	CFM	BHP
0.6							2194	0.85	1886	0.66	1580	0.49
0.8					2113	0.86	1832	0.70	1526	0.52	1219	0.37
1.0			2182	0.98	1776	0.73	1472	0.55	1166	0.39		
1.2	2053	1.00	1780	0.80	1440	0.59	1111	0.40				
1.4	1759	0.86	1421	0.64	1104	0.46						
1.6	1442	0.72	1095	0.50								
1.8	1095	0.56										

**AIRFLOW DATA — CPH060**

**STANDARD DIRECT DRIVE MOTOR — HORIZONTAL**

CFM	STATIC	AMPS	WATTS	RPM	SPEED TAP
1355	0.1	1.57	174	599	T1
1281	0.2	1.66	182	651	
1235	0.3	1.76	196	693	
1168	0.4	1.81	202	726	
1118	0.5	1.94	218	775	
1049	0.6	2.03	232	819	
982	0.7	2.10	240	858	
922	0.8	2.14	246	885	
871	0.9	2.25	260	927	
1544	0.1	2.04	234	660	T2
1490	0.2	2.17	250	704	
1427	0.3	2.25	260	742	
1370	0.4	2.35	276	781	
1319	0.5	2.42	282	809	
1274	0.6	2.52	296	849	
1210	0.7	2.62	316	891	
1137	0.8	2.73	326	935	
1106	0.9	2.77	336	957	
2099	0.1	4.13	516	825	T3
2068	0.2	4.25	536	852	
2029	0.3	4.37	552	885	
1971	0.4	4.48	568	913	
1911	0.5	4.61	586	950	
1876	0.6	4.73	604	973	
1821	0.7	4.86	622	1012	
1792	0.8	4.91	630	1028	
1740	0.9	5.03	648	1067	
2233	0.1	4.76	608	863	T4
2168	0.2	4.91	628	896	
2125	0.3	5.02	640	924	
2070	0.4	5.14	660	951	
2050	0.5	5.27	678	979	
1980	0.6	5.41	696	1012	
1954	0.7	5.47	704	1034	
1893	0.8	5.60	724	1067	
1852	0.9	5.70	736	1089	
2322	0.1	5.44	710	904	T5
2294	0.2	5.55	726	934	
2254	0.3	5.68	742	958	
2201	0.4	5.80	766	990	
2147	0.5	5.93	782	1017	
2117	0.6	6.01	788	1039	
2081	0.7	6.12	808	1060	
2017	0.8	6.22	822	1094	
1932	0.9	6.10	804	1111	

**STANDARD DIRECT DRIVE MOTOR — DOWN SHOT**

CFM	STATIC	AMPS	WATTS	RPM	SPEED TAP
1334	0.1	1.65	180	627	T1
1286	0.2	1.75	192	665	
1212	0.3	1.83	202	715	
1144	0.4	1.94	216	759	
1077	0.5	1.99	222	792	
1039	0.6	2.10	238	830	
953	0.7	2.17	248	874	
904	0.8	2.27	258	913	
825	0.9	2.30	266	940	
1512	0.1	2.12	240	682	T2
1469	0.2	2.24	254	720	
1397	0.3	2.31	264	759	
1333	0.4	2.44	282	803	
1285	0.5	2.54	296	836	
1221	0.6	2.59	304	874	
1173	0.7	2.72	322	913	
1118	0.8	2.77	328	946	
1049	0.9	2.90	344	984	
2053	0.1	4.27	540	869	T3
2014	0.2	4.39	558	896	
1999	0.3	4.60	576	929	
1947	0.4	4.68	588	957	
1897	0.5	4.79	608	989	
1857	0.6	4.87	620	1012	
1763	0.7	4.99	640	1050	
1741	0.8	5.06	650	1072	
1669	0.9	5.19	668	1105	
2137	0.1	4.95	634	913	T4
2093	0.2	5.07	652	940	
2095	0.3	5.19	670	962	
2026	0.4	5.28	682	990	
1980	0.5	5.40	698	1018	
1961	0.6	5.49	720	1039	
1914	0.7	5.58	732	1072	
1845	0.8	5.70	742	1100	
1766	0.9	5.69	740	1127	
2299	0.1	5.70	742	942	T5
2233	0.2	5.80	748	969	
2217	0.3	5.90	768	990	
2157	0.4	6.07	786	1018	
2131	0.5	6.12	804	1045	
2060	0.6	6.21	816	1073	
2015	0.7	6.30	820	1095	
1940	0.8	6.27	816	1111	
1862	0.9	6.13	790	1128	

**NOTES**

- Assumes dry coil with filter in place; SCFM correction for wet coil = 4%
- Five-ton models are shipped from the factory with speed tap set on T4.

**AIRFLOW DATA — CPH060 (CONT.)**

**STANDARD BELT DRIVE — HORIZONTAL**

ESP (" W.C.)	TURNS OPEN											
	0		1		2		3		4		5	
	CFM	BHP	CFM	BHP	CFM	BHP	CFM	BHP	CFM	BHP	CFM	BHP
0.2									2420	0.79	2198	0.64
0.4					2605	1.02	2358	0.84	2133	0.67	1874	0.52
0.6			2526	1.06	2300	0.88	2026	0.70	1806	0.55		
0.8	2529	1.15	2252	0.93	1975	0.73	1670	0.54				
1.0	2233	0.99	1943	0.78	1628	0.57						
1.2	1907	0.83	1582	0.61								

**HIGH-STATIC BELT DRIVE — HORIZONTAL**

ESP (" W.C.)	TURNS OPEN											
	0		1		2		3		4		5	
	CFM	BHP	CFM	BHP	CFM	BHP	CFM	BHP	CFM	BHP	CFM	BHP
0.6											2323	0.92
0.8									2315	1.00	2009	0.77
1.0							2308	1.09	1992	0.84	1666	0.60
1.2					2338	1.21	1992	0.92	1646	0.66		
1.4			2359	1.32	2025	1.02	1648	0.72				
1.6	2404	1.45	2056	1.13	1684	0.82						
1.8	2088	1.24	1722	0.92								

**STANDARD BELT DRIVE — DOWN SHOT**

ESP (" W.C.)	TURNS OPEN											
	0		1		2		3		4		5	
	CFM	BHP	CFM	BHP	CFM	BHP	CFM	BHP	CFM	BHP	CFM	BHP
0.2					2579	1.01	2368	0.85	2175	0.69	1961	0.55
0.4			2513	1.05	2318	0.89	2089	0.73	1906	0.59	1666	0.44
0.6	2514	1.14	2276	0.94	2045	0.77	1797	0.60	1604	0.47		
0.8	2261	1.01	2017	0.82	1760	0.63						
1.0	1989	0.87	1730	0.68								
1.2	1695	0.72										

**HIGH-STATIC BELT DRIVE — DOWN SHOT**

ESP (" W.C.)	TURNS OPEN											
	0		1		2		3		4		5	
	CFM	BHP	CFM	BHP	CFM	BHP	CFM	BHP	CFM	BHP	CFM	BHP
0.6									2331	1.01	2072	0.80
0.8							2324	1.10	2059	0.87	1791	0.66
1.0					2350	1.21	2058	0.95	1774	0.72		
1.2			2367	1.33	2086	1.06	1776	0.79				
1.4	2404	1.45	2111	1.17	1805	0.89						
1.6	2136	1.28	1835	0.99								
1.8	1868	1.10										

**AIRFLOW DATA — CPH072**

**CPH072 STANDARD BELT DRIVE — HORIZONTAL**

ESP ("W.C.)	0 TURNS		1 TURN		2 TURNS		3 TURNS		4 TURNS		5 TURNS	
	CFM	BHP	CFM	BHP	CFM	BHP	CFM	BHP	CFM	BHP	CFM	BHP
0.2							2784	1.30	2582	0.83	2411	0.79
0.4					2814	1.34	2620	1.19	2342	0.72	2105	0.66
0.6			2665	1.34	2583	1.19	2398	1.06	2103	0.62	1902	0.57
0.8	2689	1.38	2492	1.22	2370	1.07	2142	0.91	1816	0.51		
1.0	2438	1.22	2275	1.09	2098	0.92	1883	0.78				
1.2	2250	1.10	1996	0.92								

**CPH072 STANDARD BELT DRIVE — DOWN SHOT**

ESP ("W.C.)	0 TURNS		1 TURN		2 TURNS		3 TURNS		4 TURNS		5 TURNS	
	CFM	BHP	CFM	BHP	CFM	BHP	CFM	BHP	CFM	BHP	CFM	BHP
0.2					2771	1.27	2567	1.05	2421	0.88	2220	0.71
0.4			2753	1.38	2573	1.15	2382	0.95	2186	0.77	1980	0.61
0.6	2655	1.42	2548	1.24	2360	1.02	2119	0.81	1934	0.65		
0.8	2470	1.30	2331	1.11	2111	0.89	1868	0.69				
1.0	2296	1.18	2078	0.96	1840	0.75						
1.2	2040	1.02										

**CPH072 HIGH STATIC BELT DRIVE — HORIZONTAL**

ESP ("W.C.)	0 TURNS		1 TURN		2 TURNS		3 TURNS		4 TURNS		5 TURNS	
	CFM	BHP	CFM	BHP	CFM	BHP	CFM	BHP	CFM	BHP	CFM	BHP
0.6									2746	1.38	2515	1.12
0.8							2721	1.47	2494	1.21	2261	0.97
1.0					2689	1.56	2500	1.32	2255	1.06	1994	0.83
1.2			2752	1.74	2473	1.40	2252	1.15	1996	0.91		
1.4	2802	1.88	2487	1.53	2286	1.27	2037	1.02				
1.6	2553	1.67	2308	1.40	1997	1.08						
1.8	2355	1.51	2014	1.19								
2.0	2055	1.29										

**CPH072 HIGH STATIC BELT DRIVE — DOWN SHOT**

ESP ("W.C.)	0 TURNS		1 TURN		2 TURNS		3 TURNS		4 TURNS		5 TURNS	
	CFM	BHP	CFM	BHP	CFM	BHP	CFM	BHP	CFM	BHP	CFM	BHP
0.6					2793	1.64	2603	1.39	2450	1.18	2270	0.97
0.8			2903	1.87	2696	1.57	2369	1.23	2236	1.05	1987	0.82
1.0	2776	1.86	2682.5	1.69	2445	1.38	2196	1.12	1968	0.90		
1.2	2599	1.71	2539	1.57	2310	1.29	1932	0.96				
1.4	2424	1.57	2305	1.40	2032	1.11						
1.6	2172	1.38	2017	1.19								
1.8	1953	1.22										

## HEAT KIT ELECTRICAL DATA — 3 TONS

MODEL AND HEAT KIT USAGE	MCA <sup>1</sup> @ 208 / 240V	MOP <sup>2</sup> (AMPS) @ 208 / 240V	ACTUAL KW & BTU @ 240V	RECOMMENDED AIRFLOW RANGE
CPH036***1D***	25	40		
EHK1-10	67 / 77	70 / 80	10	1250-1350 CFM
EHK1-15	89 / 103	90 / 110	15	1400-1440 CFM
CPH036***3D***	17	25		
EHK3-10	41 / 47	45 / 50	10	1250-1350 CFM
EHK3-15	54 / 62	60 / 70	15	1400-1440 CFM
CPH036***3B***	18	25		
EHK3-10	42 / 48	45 / 50	10	1250-1350 CFM
EHK3-15	55 / 63	60 / 70	15	1400-1440 CFM

MODEL AND HEAT KIT USAGE	MCA <sup>1</sup> @ 480V	MOP <sup>2</sup> (AMPS) @ 480V	ACTUAL KW & BTU @ 480V	RECOMMENDED AIRFLOW RANGE
CPH036***4B***	10	15		
EHK4-10	25	25	10	1250-1350 CFM
EHK4-15	33	35	15	1400-1440 CFM

MODEL AND HEAT KIT USAGE	MCA <sup>1</sup> @ 575V	MOP <sup>2</sup> (AMPS) @ 575V	ACTUAL KW & BTU @ 575V	RECOMMENDED AIRFLOW RANGE
CPH036***7B***	8	15		
EHK7-10	20	25	10	1400-1475 CFM
EHK7-15	26	30	15	1575-1650 CFM

<sup>1</sup> Minimum Circuit Ampacity

<sup>2</sup> Maximum Overcurrent Protection device

### kW CORRECTION FACTORS

kW CORRECTION FACTOR FOR 1- & 3-PHASE UNITS					
SUPPLY VOLTAGE	240	230	220	210	208
CORRECTION FACTOR	1	0.93	0.82	0.78	0.76

kW CORRECTION FACTOR FOR 480V UNITS			
ACTUAL VOLTAGE	460	440	430
CORRECTION FACTOR	0.92	0.84	0.8

For other voltage use  $\text{voltage}^2 / 480^2$

kW CORRECTION FACTOR FOR 575V UNITS			
SUPPLY VOLTAGE	560	550	540
CORRECTION FACTOR	0.95	0.91	0.88

Multiply rated kW by correction factor to get actual kW

### MINIMUM AIRFLOW FOR ELECTRIC HEAT

HEATER SIZE	MINIMUM CFM	
	A MODELS	B MODELS
10 kW	1,250	1,250
15 kW	1,400	1,250

## HEAT KIT ELECTRICAL DATA — 4 TONS

MODEL AND HEAT KIT USAGE	MCA <sup>1</sup> @ 208 / 240V	MOP <sup>2</sup> (AMPS) @ 208 / 240V	ACTUAL kW & BTU @ 240V	RECOMMENDED AIRFLOW RANGE
CPH048***1D***	29	45		
EHK1-10	70 / 81	80 / 90	10	1400-1800 CFM
EHK1-15	93 / 107	100 / 110	15	1575-1800 CFM
EHK1-18	107 / 123	110 / 125	18	1575-1800 CFM
CPH048***3D***	21	30		
EHK3-10	44 / 51	45 / 60	10	1400-1800 CFM
EHK3-15	57 / 66	60 / 70	15	1575-1800 CFM
EHK3-18	65 / 75	70 / 80	18	1575-1800 CFM
CPH048***3B***	22	30		
EHK3-10	45 / 52	45 / 60	10	1400-1800 CFM
EHK3-15	58 / 67	60 / 70	15	1575-1800 CFM
EHK3-18	66 / 76	70 / 80	18	1575-1800 CFM

MODEL AND HEAT KIT USAGE	MCA <sup>1</sup> @ 480V	MOP <sup>2</sup> (AMPS) @ 480V	ACTUAL kW & BTU @ 480V	RECOMMENDED AIRFLOW RANGE
CPH048***4B***	10	15		
EHK4-10	25	30	10	1400-1800 CFM
EHK4-15	33	35	15	1575-1800 CFM
EHK4-18	37	40	18	1575-1800 CFM

MODEL AND HEAT KIT USAGE	MCA <sup>1</sup> @ 575V	MOP <sup>2</sup> (AMPS) @ 575V	ACTUAL kW & BTU @ 575V	RECOMMENDED AIRFLOW RANGE
CPH048***7B***	8	15		
EHK7-10	21	25	10	1400-1800 CFM
EHK7-15	27	30	15	1575-1800 CFM
EHK7-18	31	35	18	1575-1800 CFM

<sup>1</sup> Minimum Circuit Ampacity

<sup>2</sup> Maximum Overcurrent Protection device

### kW CORRECTION FACTORS

kW CORRECTION FACTOR FOR 1- & 3-PHASE UNITS					
SUPPLY VOLTAGE	240	230	220	210	208
CORRECTION FACTOR	1	0.93	0.82	0.78	0.76

kW CORRECTION FACTOR FOR 480V UNITS			
ACTUAL VOLTAGE	460	440	430
CORRECTION FACTOR	0.92	0.84	0.8

For other voltage use  $\text{voltage}^2 / 480^2$

kW CORRECTION FACTOR FOR 575V UNITS			
SUPPLY VOLTAGE	560	550	540
CORRECTION FACTOR	0.95	0.91	0.88

Multiply rated kW by correction factor to get actual kW

## HEAT KIT ELECTRICAL DATA — 5 TONS

MODEL AND HEAT KIT USAGE	MCA <sup>1</sup> @ 208 / 240V	MOP <sup>2</sup> (AMPS) @ 208 / 240V	ACTUAL kW & BTU @ 240V	RECOMMENDED AIRFLOW RANGE
CPH060***1D***	42	60		
EHK1-10	82 / 94	90 / 110	10	1750-2250 CFM
EHK1-15	104 / 120	110 / 125	15	1750-2250 CFM
EHK1-20	127 / 146	150 / 150	20	1850-2250 CFM
CPH060***3D***	29	45		
EHK3-10	51 / 59	60 / 60	10	1750-2250 CFM
EHK3-15	64 / 74	70 / 80	15	1750-2250 CFM
EHK3-20	77 / 89	80 / 90	20	1850-2250 CFM
CPH060***3B***	25	40		
EHK3-10	48 / 55	50 / 60	10	1750-2250 CFM
EHK3-15	61 / 70	70 / 80	15	1750-2250 CFM
EHK3-20	74 / 85	80 / 90	20	1850-2250 CFM

MODEL AND HEAT KIT USAGE	MCA <sup>1</sup> @ 480V	MOP <sup>2</sup> (AMPS) @ 480V	ACTUAL kW & BTU @ 480V	RECOMMENDED AIRFLOW RANGE
CPH060***4B***	12	20		
EHK4-10	27	30	10	1750-2250 CFM
EHK4-15	35	40	15	1750-2250 CFM
EHK4-20	43	45	20	1850-2250 CFM

MODEL AND HEAT KIT USAGE	MCA <sup>1</sup> @ 575V	MOP <sup>2</sup> (AMPS) @ 575V	ACTUAL kW & BTU @ 575V	RECOMMENDED AIRFLOW RANGE
CPH060***7B***	10	15		
EHK7-10	23	25	10	1750-2250 CFM
EHK7-15	29	30	15	1750-2250 CFM
EHK7-20	35	40	20	1850-2250 CFM

<sup>1</sup> Minimum Circuit Ampacity

<sup>2</sup> Maximum Overcurrent Protection Device

### kW CORRECTION FACTORS

kW CORRECTION FACTOR FOR 1- & 3-PHASE UNITS					
SUPPLY VOLTAGE	240	230	220	210	208
CORRECTION FACTOR	1	0.93	0.82	0.78	0.76

kW CORRECTION FACTOR FOR 480V UNITS			
ACTUAL VOLTAGE	460	440	430
CORRECTION FACTOR	0.92	0.84	0.8

For other voltage use voltage<sup>2</sup> / 480<sup>2</sup>

kW CORRECTION FACTOR FOR 575V UNITS			
SUPPLY VOLTAGE	560	550	540
CORRECTION FACTOR	0.95	0.91	0.88

Multiply rated kW by correction factor to get actual kW

### MINIMUM AIRFLOW FOR ELECTRIC HEAT

HEATER SIZE	MINIMUM CFM	
	A MODELS	B MODELS
10	1,750	1,700
15	1,750	1,700
20	1,850	1,880

## HEAT KIT ELECTRICAL DATA — 6 TONS

MODEL AND HEAT KIT USAGE	MCA <sup>1</sup> @ 208 / 240V	MOP <sup>2</sup> (AMPS) @ 208 / 240V	ACTUAL KW & BTU @ 240V	RECOMMENDED AIRFLOW RANGE
CPH072XX3B***	31	45		
EHK3-10	61	70	10	2,100 - 2,700 CFM
EHK3-15	76	80	15	2,100 - 2,700 CFM
EHK3-20	91	100	20	2,100 - 2,700 CFM
EHK3-25	106	110	25	2,100 - 2,700 CFM

MODEL AND HEAT KIT USAGE	MCA <sup>1</sup> @ 480V	MOP <sup>2</sup> (AMPS) @ 480V	ACTUAL KW & BTU @ 480V	RECOMMENDED AIRFLOW RANGE
CPH072XX4B***	16	25		
EHK4-10	31	35	10	2,100 - 2,700 CFM
EHK4-15	38	40	15	2,100 - 2,700 CFM
EHK4-20	46	50	20	2,100 - 2,700 CFM
EHK4-25	53	60	25	2,100 - 2,700 CFM

MODEL AND HEAT KIT USAGE	MCA <sup>1</sup> @ 575V	MOP <sup>2</sup> (AMPS) @ 575V	ACTUAL KW & BTU @ 575V	RECOMMENDED AIRFLOW RANGE
CPH072XX7B***	13	15		
EHK7-10	25	30	10	2,100 - 2,700 CFM
EHK7-15	31	35	15	2,100 - 2,700 CFM
EHK7-20	38	40	20	2,100 - 2,700 CFM
EHK7-25	44	45	25	2,100 - 2,700 CFM

<sup>1</sup> Minimum Circuit Ampacity

<sup>2</sup> Maximum Overcurrent Protection Device

Note: All heaters have single-point entry kit

KW CORRECTION FACTOR FOR 1- & 3-PHASE UNITS				
Supply Voltage	240	230	220	210
Correction Factor	1	0.92	0.84	0.77

KW CORRECTION FACTOR FOR 480V UNITS			
Actual Voltage	460	440	430
Correction Factor	0.92	0.84	0.8

For other voltage use  $\text{voltage}^2 / 480^2$

KW CORRECTION FACTOR FOR 575V UNITS			
Supply Voltage	560	550	540
Correction Factor	0.95	0.91	0.88

Multiply rated kW by correction factor to get actual kW.

### MINIMUM AIRFLOW FOR ELECTRIC HEAT

HEATER SIZE	MINIMUM CFM
10	2,100
15	2,100
20	2,100
25	2,100



## EXPANDED HEATING DATA

### CPH 036B

	OUTDOOR AMBIENT TEMPERATURE																	
	65	60	55	50	47	45	40	35	30	25	20	17	15	10	5	0	-5	-10
MBh	43.5	41.2	38.8	36.2	<b>34.6</b>	33.5	31.1	28.7	23.7	21.9	20.1	19.0	18.3	16.4	14.6	12.7	10.8	8.9
T/R	33.6	31.8	29.9	28.0	<b>26.7</b>	25.9	24.0	22.2	18.3	16.9	15.5	14.7	14.1	12.7	11.2	9.8	8.4	6.8
kW	2.93	2.88	2.82	2.77	<b>2.74</b>	2.72	2.66	2.61	2.63	2.58	2.52	2.49	2.47	2.41	2.36	2.30	2.25	2.19
Amps	10.7	10.1	9.6	9.2	<b>8.9</b>	8.8	8.4	8.1	7.8	7.6	7.3	7.2	7.1	6.9	6.6	6.3	6.0	5.6
COP	4.34	4.19	4.02	3.83	<b>3.70</b>	3.61	3.42	3.22	2.63	2.48	2.33	2.23	2.17	1.99	1.81	1.61	1.41	1.18
EER	14.8	14.3	13.7	13.1	<b>12.6</b>	12.3	11.7	11.0	9.0	8.5	8.0	7.6	7.4	6.8	6.2	5.5	4.8	4.0
HI PR	357	342	329	314	<b>307</b>	301	290	278	266	254	244	238	234	225	216	208	200	193
LO PR	135	126	118	108	<b>102</b>	98	90	80	73	65	57	53	51	43	37	31	27	22

### CPH048B

	OUTDOOR AMBIENT TEMPERATURE																	
	65	60	55	50	47	45	40	35	30	25	20	17	15	10	5	0	-5	-10
MBh	56.6	53.6	50.4	47.1	<b>45.0</b>	43.6	40.5	37.4	30.9	28.5	26.3	24.8	23.9	21.4	19.0	16.6	14.1	11.6
T/R	32.7	31.0	29.2	27.3	<b>26.0</b>	25.2	23.4	21.6	17.9	16.5	15.2	14.4	13.8	12.4	11.0	9.6	8.2	6.7
kW	4.00	3.93	3.85	3.78	<b>3.74</b>	3.71	3.64	3.56	3.47	3.39	3.32	3.28	3.25	3.18	3.11	3.04	2.97	2.90
Amps	14.9	14.0	13.3	12.7	<b>12.4</b>	12.2	11.7	11.3	11.0	10.6	10.3	10.1	10.0	9.7	9.3	8.9	8.5	8.0
COP	4.14	3.99	3.83	3.65	<b>3.52</b>	3.44	3.26	3.07	2.61	2.46	2.31	2.21	2.15	1.97	1.79	1.60	1.39	1.17
EER	14.1	13.6	13.1	12.5	<b>12.0</b>	11.8	11.1	10.5	8.9	8.4	7.9	7.6	7.3	6.7	6.1	5.5	4.8	4.0
HI PR	403	387	372	355	<b>347</b>	341	327	314	301	287	276	269	265	254	245	235	226	218
LO PR	134	124	116	107	<b>101</b>	97	89	79	72	64	56	52	50	43	37	31	27	21

### CPH 060B

	OUTDOOR AMBIENT TEMPERATURE																	
	65	60	55	50	47	45	40	35	30	25	20	17	15	10	5	0	-5	-10
MBh	71.6	67.8	63.8	59.7	<b>57.0</b>	55.2	51.3	47.3	39.9	36.8	33.9	32.0	30.8	27.6	24.5	21.4	18.2	14.9
T/R	34.0	32.2	30.3	28.3	<b>27.1</b>	26.2	24.4	22.5	18.9	17.5	16.1	15.2	14.6	13.1	11.6	10.2	8.7	7.1
kW	4.83	4.74	4.64	4.55	<b>4.50</b>	4.46	4.37	4.27	4.16	4.07	3.97	3.92	3.88	3.79	3.70	3.61	3.51	3.42
Amps	17.9	16.8	15.8	15.0	<b>14.6</b>	14.3	13.7	13.1	12.6	12.2	11.7	11.5	11.4	10.9	10.3	9.9	9.3	8.6
COP	4.34	4.19	4.02	3.84	<b>3.71</b>	3.63	3.44	3.24	2.80	2.65	2.50	2.39	2.32	2.14	1.94	1.73	1.52	1.28
EER	14.8	14.3	13.7	13.1	<b>12.7</b>	12.4	11.8	11.1	9.6	9.1	8.5	8.2	7.9	7.3	6.6	5.9	5.2	4.4
HI PR	404	387	372	356	<b>348</b>	341	328	315	301	288	276	270	265	255	245	235	227	219
LO PR	130	121	113	104	<b>98</b>	94	87	77	70	62	55	51	49	42	36	30	26	21

### CPH072

	OUTDOOR AMBIENT TEMPERATURE																	
	65	60	55	50	47	45	40	35	30	25	20	17	15	10	5	0	-5	-10
MBh	88.0	83.3	78.4	73.3	<b>70.0</b>	67.8	63.0	58.1	49.0	45.2	41.6	39.3	37.9	34.0	30.1	26.3	22.4	18.4
T/R	37.9	35.9	33.8	31.6	<b>30.1</b>	29.2	27.1	25.0	21.1	19.5	17.9	16.9	16.3	14.6	13.0	11.3	9.7	7.9
kW	6.10	5.98	5.87	5.76	<b>5.69</b>	5.64	5.53	5.42	5.24	5.13	5.02	4.96	4.91	4.80	4.69	4.58	4.47	4.36
Amps	23.4	22.1	20.9	20.0	<b>19.4</b>	19.1	18.3	17.6	17.1	16.5	16.0	15.7	15.5	15.0	14.3	13.7	13.1	12.2
COP	4.22	4.07	3.91	3.73	<b>3.60</b>	3.52	3.33	3.14	2.73	2.58	2.43	2.32	2.26	2.07	1.88	1.68	1.47	1.23
EER	14.4	13.9	13.4	12.7	<b>12.3</b>	12.0	11.4	10.7	9.3	8.8	8.3	7.9	7.7	7.1	6.4	5.7	5.0	4.2
HI PR	368	352	339	324	<b>316</b>	310	298	286	274	262	251	245	241	232	223	214	206	199
LO PR	131	121	114	104	<b>99</b>	95	87	78	70	63	55	51	49	42	36	30	26	21

Above information is for 2150 CFM & 70° indoor dry bulb; instantaneous capacity listed.

kW = Total system power

High pressure measured at liquid line access fitting.

Amps: Unit Amps (comp+evap motor+condenser fan motor)

Low pressure measured at compressor suction access fitting.

EXPANDED COOLING DATA — CPH036

IDB	AIRFLOW	OUTDOOR AMBIENT TEMPERATURE												ENTERING INDOOR WET BULB TEMPERATURE												
		65°F				75°F				85°F				95°F				105°F				115°F				
		59	63	67	71	59	63	67	71	59	63	67	71	59	63	67	71	59	63	67	71	59	63	67	71	
1350	MBh	34.3	35.5	38.9	-	33.5	34.7	38.0	-	32.7	33.9	37.1	-	31.9	33.1	36.2	-	30.3	31.4	34.4	-	28.1	29.1	31.9	-	
	S/T	0.77	0.65	0.45	-	0.80	0.67	0.46	-	0.82	0.69	0.48	-	0.85	0.71	0.49	-	0.88	0.74	0.51	-	0.89	0.74	0.51	-	
	ΔT	18	16	12	-	18	16	12	-	18	16	12	-	18	16	12	-	18	16	12	-	17	15	11	-	
	kW	2.54	2.59	2.67	-	2.73	2.78	2.86	-	2.89	2.95	3.04	-	3.03	3.09	3.19	-	3.15	3.21	3.31	-	3.25	3.32	3.42	-	
	HI PR	238	256	270	-	267	287	303	-	304	327	345	-	346	372	393	-	389	419	442	-	430	463	488	-	
	LO PR	107	114	124	-	113	120	131	-	118	125	137	-	124	131	144	-	130	138	150	-	134	143	156	-	
	MBh	33.3	34.5	37.8	-	32.5	33.7	36.9	-	31.7	32.9	36.1	-	31.0	32.1	35.2	-	29.4	30.5	33.4	-	27.3	28.3	31.0	-	
	S/T	0.74	0.62	0.43	-	0.76	0.64	0.44	-	0.78	0.65	0.45	-	0.81	0.68	0.47	-	0.84	0.70	0.49	-	0.85	0.71	0.49	-	
	ΔT	19	16	12	-	19	16	13	-	19	17	13	-	19	17	13	-	19	16	12	-	18	15	12	-	
	kW	2.53	2.58	2.65	-	2.71	2.76	2.84	-	2.86	2.92	3.01	-	3.00	3.07	3.16	-	3.12	3.19	3.29	-	3.23	3.29	3.40	-	
Amps	8.5	8.7	8.9	-	9.1	9.2	9.5	-	9.7	9.8	10.1	-	10.2	10.4	10.6	-	10.7	10.9	11.2	-	11.2	11.4	11.7	-		
HI PR	236	253	268	-	264	284	300	-	301	323	342	-	342	368	389	-	385	414	438	-	426	458	484	-		
LO PR	106	113	123	-	112	119	130	-	116	124	135	-	122	130	142	-	128	136	149	-	133	141	154	-		
1200	MBh	30.7	31.9	34.9	-	30.0	31.1	34.1	-	29.3	30.4	33.3	-	28.6	29.6	32.5	-	27.2	28.2	30.8	-	25.2	26.1	28.6	-	
	S/T	0.71	0.59	0.41	-	0.74	0.62	0.43	-	0.76	0.63	0.44	-	0.78	0.65	0.45	-	0.81	0.68	0.47	-	0.82	0.68	0.47	-	
	ΔT	19	17	13	-	19	17	13	-	19	17	13	-	20	17	13	-	19	17	13	-	18	16	12	-	
	kW	2.47	2.52	2.59	-	2.64	2.70	2.78	-	2.80	2.86	2.94	-	2.93	2.99	3.09	-	3.05	3.11	3.21	-	3.15	3.22	3.32	-	
	Amps	8.4	8.5	8.7	-	8.9	9.0	9.3	-	9.4	9.6	9.9	-	9.9	10.1	10.4	-	10.4	10.7	10.9	-	10.9	11.2	11.5	-	
	HI PR	228	246	260	-	256	276	291	-	292	314	331	-	332	357	377	-	374	402	425	-	413	444	469	-	
	LO PR	103	109	120	-	109	116	126	-	113	120	131	-	119	126	138	-	124	132	144	-	129	137	149	-	
	1050	MBh	34.9	35.9	38.9	41.7	34.1	35.1	38.0	40.7	33.3	34.2	37.1	39.8	32.4	33.4	36.2	38.8	30.8	31.7	34.4	36.9	28.6	29.4	31.8	34.2
		S/T	0.88	0.79	0.60	0.38	0.91	0.81	0.62	0.40	0.93	0.84	0.63	0.41	0.96	0.86	0.65	0.42	1.00	0.90	0.68	0.44	1.00	0.90	0.68	0.44
		ΔT	21	19	16	11	21	19	16	11	21	19	16	11	21	20	16	11	21	19	16	11	19	18	15	10
kW		2.56	2.61	2.69	2.77	2.75	2.80	2.89	2.98	2.91	2.97	3.06	3.15	3.05	3.12	3.21	3.31	3.17	3.24	3.34	3.45	3.28	3.35	3.45	3.56	
Amps		8.7	8.8	9.0	9.3	9.2	9.4	9.6	9.9	9.8	10.0	10.2	10.5	10.3	10.5	10.8	11.1	10.8	11.1	11.4	11.7	11.4	11.6	11.9	12.3	
HI PR		240	259	273	285	270	290	306	320	307	330	349	364	349	376	397	414	393	423	447	466	434	467	493	515	
LO PR		108	115	126	134	114	122	133	141	119	126	138	147	125	133	145	154	131	139	152	162	135	144	157	167	
MBh		33.9	34.9	37.7	40.5	33.1	34.1	36.9	39.6	32.3	33.2	36.0	38.6	31.5	32.4	35.1	37.7	29.9	30.8	33.3	35.8	27.7	28.5	30.9	33.2	
S/T		0.84	0.75	0.57	0.37	0.87	0.78	0.59	0.38	0.89	0.80	0.60	0.39	0.92	0.82	0.62	0.40	0.95	0.85	0.65	0.42	0.96	0.86	0.65	0.42	
ΔT		22	20	16	11	22	20	17	11	22	20	17	11	22	20	17	11	22	20	17	11	20	19	15	11	
kW	2.55	2.60	2.67	2.75	2.73	2.78	2.86	2.95	2.89	2.95	3.04	3.13	3.03	3.09	3.19	3.29	3.15	3.21	3.31	3.42	3.25	3.32	3.43	3.54		
Amps	8.6	8.8	9.0	9.2	9.1	9.3	9.5	9.8	9.7	9.9	10.2	10.5	10.2	10.4	10.7	11.0	10.8	11.0	11.3	11.6	11.3	11.5	11.8	12.2		
HI PR	238	256	270	282	267	287	303	316	304	327	345	360	346	372	393	410	389	419	442	461	430	463	489	510		
LO PR	107	114	124	133	113	120	131	140	118	125	137	146	124	131	144	153	130	138	150	160	134	143	156	166		
MBh	31.3	32.2	34.8	37.4	30.5	31.4	34.0	36.5	29.8	30.7	33.2	35.6	29.1	29.9	32.4	34.8	27.6	28.4	30.8	33.0	25.6	26.3	28.5	30.6		
S/T	0.81	0.72	0.55	0.35	0.84	0.75	0.57	0.36	0.86	0.77	0.58	0.37	0.89	0.79	0.60	0.39	0.92	0.82	0.62	0.40	0.93	0.83	0.63	0.40		
ΔT	22	20	17	12	22	21	17	12	22	21	17	12	23	21	17	12	22	21	17	12	21	19	16	11		
kW	2.49	2.54	2.61	2.69	2.66	2.72	2.80	2.88	2.82	2.88	2.96	3.06	2.96	3.02	3.11	3.21	3.07	3.14	3.24	3.34	3.17	3.24	3.34	3.45		
Amps	8.4	8.6	8.8	9.0	8.9	9.1	9.3	9.6	9.5	9.7	9.9	10.2	10.0	10.2	10.5	10.8	10.5	10.7	11.0	11.4	11.0	11.2	11.6	11.9		
HI PR	231	248	262	274	259	279	294	307	295	317	335	349	335	361	381	398	377	406	429	447	417	449	474	494		
LO PR	104	111	121	129	110	117	128	136	114	121	133	141	120	128	139	148	126	134	146	155	130	138	151	161		

IDB = Entering Indoor Dry Bulb Temperature  
 High & low pressures are measured at the liquid & suction service ports.  
 Shaded area reflects ACCA (TVNA) conditions  
 kW = Total system power  
 Amps: Unit: amps (comp.+ evaporator + condenser fan motors)

EXPANDED COOLING DATA — CPH036 (CONT.)

IDB	AIRFLOW	OUTDOOR AMBIENT TEMPERATURE												ENTERING INDOOR WET BULB TEMPERATURE												
		65°F				75°F				85°F				95°F				105°F				115°F				
		59	63	67	71	59	63	67	71	59	63	67	71	59	63	67	71	59	63	67	71	59	63	67	71	
80	1350	MBh	35.5	36.3	38.8	41.4	34.7	35.4	37.9	40.5	33.8	34.6	37.0	39.5	33.0	33.7	36.1	38.5	31.4	32.1	34.2	36.6	29.1	29.7	31.7	33.9
		S/T	0.96	0.90	0.74	0.55	1.00	0.94	0.76	0.57	1.00	0.96	0.78	0.58	1.00	1.00	0.81	0.60	1.00	1.00	0.84	0.63	1.00	1.00	0.84	0.63
	ΔT	23	22	19	16	24	23	20	16	23	23	20	16	22	23	20	16	21	22	20	16	20	20	18	15	
	kW	2.58	2.63	2.71	2.79	2.77	2.82	2.91	3.00	2.93	2.99	3.08	3.18	3.08	3.14	3.24	3.34	3.20	3.27	3.37	3.48	3.30	3.37	3.48	3.59	
	HI PR	243	261	276	288	272	293	310	323	310	333	352	367	353	380	401	418	397	427	451	470	439	472	498	520	
	LO PR	109	116	127	135	116	123	134	143	120	128	139	148	126	134	146	156	132	141	153	163	137	145	159	169	
	MBh	34.5	35.2	37.6	40.2	33.7	34.4	36.8	39.3	32.9	33.6	35.9	38.4	32.1	32.8	35.0	37.4	30.5	31.1	33.3	35.5	28.2	28.8	30.8	32.9	
	S/T	0.92	0.86	0.70	0.52	0.95	0.89	0.73	0.54	0.98	0.92	0.75	0.56	1.00	0.95	0.77	0.58	1.00	0.98	0.80	0.60	1.00	0.99	0.81	0.60	
	ΔT	24	23	20	16	25	24	20	16	25	24	21	16	25	24	21	16	23	23	20	16	22	22	19	15	
	kW	2.56	2.61	2.69	2.77	2.75	2.80	2.89	2.98	2.91	2.97	3.06	3.16	3.05	3.12	3.21	3.31	3.17	3.24	3.34	3.45	3.28	3.35	3.45	3.56	
Amps	8.7	8.8	9.0	9.3	9.2	9.4	9.6	9.9	9.8	10.0	10.2	10.5	10.3	10.5	10.8	11.1	10.8	11.1	11.4	11.7	11.4	11.6	11.9	12.3		
HI PR	240	259	273	285	270	290	306	320	307	330	349	364	349	376	397	414	393	423	447	466	434	467	493	515		
LO PR	108	115	126	134	114	122	133	141	119	126	138	147	125	133	145	154	131	139	152	162	135	144	157	167		
MBh	31.8	32.5	34.7	37.1	31.1	31.7	33.9	36.3	30.3	31.0	33.1	35.4	29.6	30.2	32.3	34.5	28.1	28.7	30.7	32.8	26.0	26.6	28.4	30.4		
S/T	0.89	0.83	0.68	0.51	0.92	0.86	0.70	0.52	0.94	0.88	0.72	0.54	0.97	0.91	0.74	0.55	1.01	0.95	0.77	0.58	1.02	0.95	0.78	0.58		
ΔT	25	24	21	16	25	24	21	17	25	24	21	17	25	24	21	17	25	24	21	17	23	22	19	15		
kW	2.51	2.56	2.63	2.71	2.69	2.74	2.82	2.91	2.84	2.90	2.99	3.08	2.98	3.04	3.14	3.23	3.10	3.16	3.26	3.37	3.20	3.27	3.37	3.48		
Amps	8.5	8.6	8.8	9.1	9.0	9.2	9.4	9.7	9.6	9.8	10.0	10.3	10.1	10.3	10.6	10.9	10.6	10.8	11.1	11.4	11.1	11.3	11.6	12.0		
HI PR	233	251	265	276	262	282	297	310	298	320	338	353	339	365	385	402	381	410	433	452	421	453	479	499		
LO PR	105	112	122	130	111	118	129	137	115	123	134	143	121	129	141	150	127	135	147	157	131	140	152	162		

85	1350	MBh	36.1	36.8	38.6	41.1	35.3	36.0	37.7	40.2	34.4	35.1	36.8	39.2	33.6	34.2	35.9	38.3	31.9	32.5	34.1	36.4	29.6	30.1	31.6	33.7
		S/T	1.00	0.98	0.88	0.71	1.00	1.00	0.91	0.74	1.00	1.00	0.94	0.76	1.00	1.00	0.97	0.78	1.00	1.00	0.96	0.78	1.00	1.00	0.96	0.78
	ΔT	25	24	23	20	24	24	23	20	23	24	23	20	23	23	24	20	22	22	23	20	20	21	21	19	
	kW	2.60	2.65	2.73	2.81	2.79	2.85	2.93	3.02	2.95	3.02	3.11	3.21	3.10	3.16	3.26	3.37	3.22	3.29	3.40	3.50	3.33	3.40	3.51	3.62	
	Amps	8.8	8.9	9.2	9.4	9.3	9.5	9.7	10.0	9.9	10.1	10.4	10.7	10.5	10.7	11.0	11.3	11.0	11.2	11.5	11.9	11.5	11.8	12.1	12.5	
	HI PR	245	264	279	291	275	296	313	326	313	337	356	371	356	384	405	422	401	431	456	475	443	477	503	525	
	LO PR	110	117	128	137	117	124	135	144	121	129	141	150	127	135	148	158	133	142	155	165	138	147	160	171	
	MBh	35.1	35.7	37.4	39.9	34.3	34.9	36.6	39.0	33.4	34.1	35.7	38.1	32.6	33.3	34.8	37.2	31.0	31.6	33.1	35.3	28.7	29.3	30.6	32.7	
	S/T	0.96	0.93	0.84	0.68	1.00	0.96	0.87	0.71	1.00	0.99	0.89	0.72	1.00	1.00	0.92	0.75	1.00	1.00	0.96	0.78	1.00	1.00	0.96	0.78	
	ΔT	26	25	24	21	26	26	24	21	26	26	24	21	25	25	25	21	24	24	24	21	22	22	23	20	
kW	2.58	2.63	2.71	2.79	2.77	2.82	2.91	3.00	2.93	2.99	3.08	3.18	3.08	3.14	3.24	3.34	3.20	3.27	3.37	3.48	3.30	3.37	3.48	3.59		
Amps	8.7	8.9	9.1	9.4	9.2	9.4	9.7	9.9	9.9	10.1	10.3	10.6	10.4	10.6	10.9	11.2	10.9	11.1	11.4	11.8	11.5	11.7	12.0	12.4		
HI PR	243	261	276	288	272	293	310	323	310	333	352	367	353	380	401	418	397	427	451	470	439	472	498	520		
LO PR	109	116	127	135	116	123	134	143	120	128	139	148	126	134	146	156	132	141	153	163	137	145	159	169		
MBh	32.4	33.0	34.6	36.9	31.6	32.2	33.8	36.0	30.9	31.5	32.9	35.1	30.1	30.7	32.1	34.3	28.6	29.2	30.5	32.6	26.5	27.0	28.3	30.2		
S/T	0.93	0.90	0.81	0.66	0.96	0.93	0.84	0.68	0.99	0.95	0.86	0.70	1.00	0.98	0.89	0.72	1.00	1.00	0.92	0.75	1.00	1.00	0.93	0.75		
ΔT	26	26	24	21	27	26	25	21	27	26	25	21	26	26	25	21	25	26	25	21	23	24	23	20		
kW	2.53	2.58	2.65	2.73	2.71	2.76	2.84	2.93	2.86	2.92	3.01	3.10	3.00	3.07	3.16	3.26	3.12	3.19	3.29	3.39	3.23	3.29	3.40	3.51		
Amps	8.5	8.7	8.9	9.2	9.1	9.2	9.5	9.7	9.7	9.8	10.1	10.4	10.2	10.4	10.6	11.0	10.7	10.9	11.2	11.5	11.2	11.4	11.7	12.1		
HI PR	235	253	268	279	264	284	300	313	301	323	341	356	342	368	389	406	385	414	438	456	425	458	483	504		
LO PR	106	113	123	131	112	119	130	139	116	124	135	144	122	130	142	151	128	136	149	159	133	141	154	164		

IDB = Entering Indoor Dry Bulb Temperature  
 High & low pressures are measured at the liquid & suction service ports.  
 Shaded area reflects AHRI (TVSA) conditions  
 kW = Total system power  
 Amps: Unit amps (comp.+ evaporator + condenser fan motors)

EXPANDED COOLING DATA — CPH048

IDB	AIRFLOW	OUTDOOR AMBIENT TEMPERATURE												ENTERING INDOOR WET BULB TEMPERATURE												
		65°F				75°F				85°F				95°F				105°F				115°F				
		59	63	67	71	59	63	67	71	59	63	67	71	59	63	67	71	59	63	67	71	59	63	67	71	
70	1800	MBh	45.1	46.7	51.2	-	44.0	45.6	50.0	-	43.0	44.5	48.8	-	41.9	43.5	47.6	-	39.8	41.3	45.2	-	36.9	38.2	41.9	-
		S/T	0.76	0.63	0.44	-	0.78	0.65	0.45	-	0.80	0.67	0.46	-	0.83	0.69	0.48	-	0.86	0.72	0.50	-	0.87	0.72	0.50	-
		ΔT	17	15	11	-	18	15	12	-	18	15	12	-	18	15	12	-	18	15	12	-	16	14	11	-
		kW	3.18	3.24	3.33	-	3.40	3.47	3.57	-	3.59	3.66	3.77	-	3.76	3.84	3.95	-	3.91	3.99	4.11	-	4.03	4.12	4.24	-
		HI PR	233	251	265	-	262	281	297	-	297	320	338	-	339	365	385	-	381	410	433	-	421	453	479	-
		LO PR	112	119	130	-	118	125	137	-	123	130	142	-	129	137	150	-	135	144	157	-	140	148	162	-
	1600	MBh	43.8	45.4	49.7	-	42.7	44.3	48.5	-	41.7	43.2	47.4	-	40.7	42.2	46.2	-	38.7	40.1	43.9	-	35.8	37.1	40.7	-
		S/T	0.72	0.60	0.42	-	0.75	0.62	0.43	-	0.77	0.64	0.44	-	0.79	0.66	0.46	-	0.82	0.69	0.47	-	0.83	0.69	0.48	-
		ΔT	18	16	12	-	18	16	12	-	18	16	12	-	18	16	12	-	18	16	12	-	17	15	11	-
		kW	3.16	3.22	3.31	-	3.38	3.44	3.54	-	3.57	3.64	3.74	-	3.74	3.81	3.92	-	3.88	3.96	4.08	-	4.00	4.08	4.21	-
		Amps	10.6	10.8	11.0	-	11.2	11.3	11.6	-	11.8	12.0	12.3	-	12.4	12.6	12.9	-	13.0	13.2	13.5	-	13.5	13.8	14.1	-
		HI PR	231	248	262	-	259	279	294	-	295	317	335	-	335	361	381	-	377	406	429	-	417	449	474	-
1400	LO PR	111	118	128	-	117	124	136	-	121	129	141	-	127	136	148	-	134	142	155	-	138	147	160	-	
	MBh	40.4	41.9	45.9	-	39.5	40.9	44.8	-	38.5	39.9	43.7	-	37.6	38.9	42.7	-	35.7	37.0	40.5	-	33.1	34.3	37.5	-	
	S/T	0.70	0.58	0.40	-	0.72	0.60	0.42	-	0.74	0.62	0.43	-	0.76	0.64	0.44	-	0.79	0.66	0.46	-	0.80	0.67	0.46	-	
	ΔT	18	16	12	-	19	16	12	-	19	16	12	-	19	16	12	-	19	16	12	-	17	15	11	-	
	kW	3.09	3.15	3.24	-	3.30	3.37	3.46	-	3.49	3.56	3.66	-	3.65	3.72	3.83	-	3.79	3.87	3.98	-	3.91	3.99	4.11	-	
	HI PR	224	241	254	-	251	270	285	-	286	307	325	-	325	350	370	-	366	394	416	-	404	435	460	-	
75	1800	LO PR	107	114	124	-	113	120	132	-	118	125	137	-	124	132	144	-	130	138	150	-	134	143	156	-
		MBh	45.8	47.2	51.1	54.8	44.8	46.1	49.9	53.6	43.7	45.0	48.7	52.3	42.6	43.9	47.5	51.0	40.5	41.7	45.1	48.5	37.5	38.6	41.8	44.9
		S/T	0.86	0.77	0.58	0.37	0.89	0.80	0.60	0.39	0.91	0.82	0.62	0.40	0.94	0.84	0.64	0.41	0.98	0.87	0.66	0.43	0.99	0.88	0.67	0.43
		ΔT	20	19	15	10	20	19	15	11	20	19	15	11	21	19	15	11	20	19	15	11	19	17	14	10
		kW	3.21	3.27	3.36	3.46	3.43	3.49	3.59	3.70	3.62	3.69	3.80	3.92	3.79	3.87	3.98	4.11	3.94	4.02	4.14	4.27	4.06	4.15	4.27	4.41
		Amps	10.7	10.9	11.1	11.4	11.3	11.5	11.8	12.1	12.0	12.2	12.5	12.8	12.6	12.8	13.1	13.5	13.2	13.4	13.7	14.1	13.7	14.0	14.4	14.8
	1600	HI PR	235	253	268	279	264	284	300	313	300	323	341	356	342	368	389	406	385	414	438	456	425	458	483	504
		LO PR	113	120	131	139	119	127	138	147	124	132	144	153	130	138	151	161	136	145	158	169	141	150	164	174
		MBh	44.5	45.8	49.6	53.2	43.5	44.8	48.4	52.0	42.4	43.7	47.3	50.8	41.4	42.6	46.1	49.5	39.3	40.5	43.8	47.0	36.4	37.5	40.6	43.6
		S/T	0.82	0.73	0.55	0.36	0.85	0.76	0.57	0.37	0.87	0.78	0.59	0.38	0.90	0.80	0.61	0.39	0.93	0.83	0.63	0.41	0.94	0.84	0.64	0.41
		ΔT	21	19	16	11	21	20	16	11	21	20	16	11	21	20	16	11	21	19	16	11	20	18	15	10
		kW	3.18	3.24	3.33	3.43	3.40	3.47	3.57	3.67	3.59	3.67	3.77	3.89	3.76	3.84	3.95	4.08	3.91	3.99	4.11	4.24	4.03	4.12	4.24	4.37
1400	Amps	10.7	10.8	11.1	11.3	11.2	11.4	11.7	12.0	11.9	12.1	12.4	12.7	12.5	12.7	13.0	13.4	13.1	13.3	13.6	14.0	13.6	13.9	14.2	14.7	
	HI PR	233	251	265	276	262	282	297	310	298	320	338	353	339	365	385	402	381	410	433	452	421	453	479	499	
	LO PR	112	119	130	138	118	125	137	146	123	130	142	152	129	137	150	159	135	144	157	167	140	148	162	173	
	MBh	41.1	42.3	45.8	49.1	40.1	41.3	44.7	48.0	39.2	40.3	43.7	46.8	38.2	39.3	42.6	45.7	36.3	37.4	40.5	43.4	33.6	34.6	37.5	40.2	
	S/T	0.79	0.71	0.53	0.34	0.82	0.73	0.55	0.36	0.84	0.75	0.57	0.37	0.87	0.78	0.59	0.38	0.90	0.80	0.61	0.39	0.91	0.81	0.61	0.39	
	ΔT	21	20	16	11	22	20	16	11	22	20	16	11	22	20	16	11	21	20	16	11	20	18	15	10	
1400	kW	3.12	3.17	3.26	3.36	3.33	3.39	3.49	3.59	3.51	3.58	3.69	3.80	3.68	3.75	3.86	3.98	3.82	3.90	4.01	4.14	3.94	4.02	4.14	4.27	
	Amps	10.5	10.6	10.9	11.1	11.0	11.2	11.5	11.8	11.7	11.9	12.2	12.5	12.2	12.5	12.8	13.1	12.8	13.0	13.4	13.7	13.4	13.6	13.9	14.3	
	HI PR	226	243	257	268	254	273	288	301	289	311	328	342	329	354	374	390	370	398	420	438	409	440	464	484	
	LO PR	108	115	126	134	114	122	133	142	119	126	138	147	125	133	145	154	131	139	152	162	135	144	157	167	

IDB = Entering Indoor Dry Bulb Temperature  
 High & low pressures are measured at the liquid & suction service ports.  
 Shaded area reflects ACCA (TVA) conditions  
 kW = Total system power  
 Amps: Unit amps (comp. + evaporator + condenser fan motors)

EXPANDED COOLING DATA — CPH048 (CONT.)

IDB	AIRFLOW	OUTDOOR AMBIENT TEMPERATURE												ENTERING INDOOR WET BULB TEMPERATURE												
		65°F				75°F				85°F				95°F				105°F				115°F				
		59	63	67	71	59	63	67	71	59	63	67	71	59	63	67	71	59	63	67	71	59	63	67	71	
80	1800	MBh	46.7	47.7	50.9	54.4	45.6	46.6	49.7	53.2	44.5	45.5	48.6	51.9	43.4	44.3	47.4	50.6	41.2	42.1	45.0	48.1	38.2	39.0	41.7	44.6
		S/T	0.94	0.88	0.72	0.54	1.00	0.92	0.75	0.56	1.00	0.94	0.76	0.57	1.00	0.97	0.79	0.59	1.00	1.00	0.82	0.61	1.00	1.00	0.83	0.62
		ΔT	22	22	19	15	23	22	19	15	23	22	19	15	22	22	19	15	21	22	19	15	20	20	18	14
		kW	3.23	3.29	3.38	3.48	3.45	3.52	3.62	3.73	3.65	3.72	3.83	3.95	3.82	3.90	4.02	4.14	3.97	4.05	4.17	4.30	4.10	4.18	4.31	4.44
		HI PR	238	256	270	282	267	287	303	316	304	327	345	360	346	372	393	410	389	419	442	461	430	462	488	509
		LO PR	114	121	132	141	120	128	140	149	125	133	145	155	131	140	153	162	138	146	160	170	142	151	165	176
	1600	MBh	45.3	46.3	49.5	52.9	44.2	45.2	48.3	51.6	43.2	44.1	47.2	50.4	42.1	43.1	46.0	49.2	40.0	40.9	43.7	46.7	37.1	37.9	40.5	43.3
		S/T	0.90	0.84	0.69	0.51	0.93	0.87	0.71	0.53	0.95	0.90	0.73	0.54	0.99	0.92	0.75	0.56	1.00	0.96	0.78	0.58	1.00	0.97	0.79	0.59
		ΔT	23	22	19	16	24	23	20	16	24	23	20	16	24	23	20	16	23	23	20	16	21	21	18	15
		kW	3.21	3.27	3.36	3.46	3.43	3.49	3.59	3.70	3.62	3.69	3.80	3.92	3.79	3.87	3.99	4.11	3.94	4.02	4.14	4.27	4.06	4.15	4.28	4.41
		Amps	10.7	10.9	11.1	11.4	11.3	11.5	11.8	12.1	12.0	12.2	12.5	12.8	12.6	12.8	13.1	13.5	13.2	13.4	13.7	14.1	13.7	14.0	14.4	14.8
		LO PR	235	253	268	279	264	284	300	313	301	323	341	356	342	368	389	406	385	414	438	456	425	458	483	504
1400	MBh	41.8	42.7	45.6	48.8	40.8	41.7	44.6	47.7	39.9	40.7	43.5	46.5	38.9	39.7	42.5	45.4	36.9	37.8	40.3	43.1	34.2	35.0	37.4	39.9	
	S/T	0.87	0.81	0.66	0.49	0.90	0.84	0.69	0.51	0.92	0.86	0.70	0.53	0.95	0.89	0.73	0.54	0.99	0.93	0.75	0.56	0.99	0.93	0.76	0.57	
	ΔT	24	23	20	16	24	23	20	16	24	23	20	16	24	23	20	16	24	23	20	16	22	21	19	15	
	kW	3.14	3.20	3.29	3.38	3.35	3.42	3.51	3.62	3.54	3.61	3.72	3.83	3.71	3.78	3.89	4.01	3.85	3.93	4.04	4.17	3.97	4.05	4.17	4.30	
	Amps	10.5	10.7	10.9	11.2	11.1	11.3	11.5	11.8	11.8	12.0	12.2	12.6	12.3	12.5	12.8	13.2	12.9	13.1	13.4	13.8	13.5	13.7	14.0	14.5	
	LO PR	228	246	260	271	256	276	291	304	292	314	331	345	332	357	377	394	374	402	424	443	413	444	469	489	
	85	MBh	47.5	48.4	50.7	54.1	46.4	47.3	49.5	52.8	45.3	46.1	48.3	51.6	44.2	45.0	47.1	50.3	42.0	42.8	44.8	47.8	38.9	39.6	41.5	44.3
		S/T	0.99	0.95	0.86	0.70	1.00	0.99	0.89	0.72	1.00	1.00	0.91	0.74	1.00	1.00	0.94	0.77	1.00	1.00	0.98	0.79	1.00	1.00	0.99	0.80
		ΔT	24	24	22	19	24	24	23	20	23	24	23	20	23	23	23	20	21	22	22	19	20	20	21	18
		kW	3.25	3.31	3.41	3.51	3.48	3.54	3.65	3.76	3.67	3.75	3.86	3.98	3.85	3.93	4.05	4.17	4.00	4.08	4.21	4.34	4.13	4.21	4.34	4.48
		Amps	10.9	11.0	11.3	11.6	11.4	11.6	11.9	12.2	12.1	12.4	12.7	13.0	12.7	13.0	13.3	13.7	13.3	13.6	13.9	14.3	13.9	14.2	14.6	15.0
		LO PR	240	259	273	285	270	290	306	319	307	330	348	363	349	376	397	414	393	423	446	466	434	467	493	514
1600		MBh	46.1	47.0	49.2	52.5	45.0	45.9	48.1	51.3	43.9	44.8	46.9	50.1	42.9	43.7	45.8	48.8	40.7	41.5	43.5	46.4	37.7	38.5	40.3	43.0
		S/T	0.94	0.91	0.82	0.67	0.98	0.94	0.85	0.69	1.00	0.97	0.87	0.71	1.00	1.00	0.90	0.73	1.00	1.00	0.93	0.76	1.00	1.00	0.94	0.76
		ΔT	25	25	23	20	25	25	23	20	25	25	23	20	25	25	24	20	23	24	23	20	22	22	22	19
		kW	3.23	3.29	3.38	3.48	3.45	3.52	3.62	3.73	3.65	3.72	3.83	3.95	3.82	3.90	4.02	4.14	3.97	4.05	4.17	4.30	4.10	4.18	4.31	4.44
		Amps	10.8	11.0	11.2	11.5	11.4	11.6	11.8	12.2	12.1	12.3	12.6	12.9	12.7	12.9	13.2	13.6	13.3	13.5	13.8	14.2	13.8	14.1	14.5	14.9
		LO PR	238	256	270	282	267	287	303	316	304	327	345	360	346	372	393	410	389	419	442	461	430	462	488	509
1400	MBh	42.5	43.4	45.4	48.5	41.5	42.4	44.4	47.3	40.6	41.3	43.3	46.2	39.6	40.3	42.2	45.1	37.6	38.3	40.1	42.8	34.8	35.5	37.2	39.7	
	S/T	0.91	0.88	0.79	0.64	0.94	0.91	0.82	0.67	0.97	0.93	0.84	0.68	1.00	0.96	0.87	0.70	1.00	1.00	0.90	0.73	1.00	1.00	0.91	0.74	
	ΔT	25	25	24	20	26	25	24	21	26	25	24	21	26	25	24	21	25	25	24	21	23	23	22	19	
	kW	3.16	3.22	3.31	3.40	3.38	3.44	3.54	3.64	3.57	3.64	3.74	3.86	3.73	3.81	3.92	4.04	3.88	3.96	4.08	4.20	4.00	4.08	4.21	4.34	
	Amps	10.6	10.8	11.0	11.3	11.2	11.3	11.6	11.9	11.8	12.0	12.3	12.6	12.4	12.6	12.9	13.3	13.0	13.2	13.5	13.9	13.5	13.8	14.1	14.6	
	LO PR	231	248	262	273	259	279	294	307	294	317	335	349	335	361	381	397	377	406	429	447	417	449	474	494	
	Notes	IDB = Entering Indoor Dry Bulb Temperature High & low pressures are measured at the liquid & suction service ports. Shaded area reflects AHRI (TVA) conditions Amps: Unit amps (comp.+ evaporator + condenser fan motors) kW = Total system power																								

EXPANDED COOLING DATA — CPH060

IDB	AIRFLOW	OUTDOOR AMBIENT TEMPERATURE												ENTERING INDOOR WET BULB TEMPERATURE												
		65°F				75°F				85°F				95°F				105°F				115°F				
		59	63	67	71	59	63	67	71	59	63	67	71	59	63	67	71	59	63	67	71	59	63	67	71	
2190	MBh	58.3	60.4	66.2	-	56.9	59.0	64.7	-	55.6	57.6	63.1	-	54.2	56.2	61.6	-	51.5	53.4	58.5	-	47.7	49.5	54.2	-	
	S/T	0.73	0.61	0.42	-	0.75	0.63	0.44	-	0.77	0.65	0.45	-	0.80	0.67	0.46	-	0.83	0.69	0.48	-	0.84	0.70	0.48	-	
	ΔT	18	15	12	-	18	16	12	-	18	16	12	-	18	16	12	-	18	16	12	-	17	14	11	-	
	kW	3.97	4.06	4.18	-	4.27	4.36	4.50	-	4.54	4.64	4.78	-	4.77	4.88	5.03	-	4.97	5.08	5.25	-	5.14	5.25	5.43	-	
	HI PR	244	262	277	-	273	294	311	-	311	335	353	-	354	381	402	-	398	429	453	-	440	474	500	-	
	LO PR	107	114	124	-	113	120	131	-	118	125	137	-	124	131	144	-	130	138	150	-	134	143	156	-	
	MBh	56.6	58.7	64.3	-	55.3	57.3	62.8	-	54.0	55.9	61.3	-	52.7	54.6	59.8	-	50.0	51.8	56.8	-	46.3	48.0	52.6	-	
	S/T	0.69	0.58	0.40	-	0.72	0.60	0.42	-	0.74	0.62	0.43	-	0.76	0.64	0.44	-	0.79	0.66	0.46	-	0.80	0.67	0.46	-	
	ΔT	19	16	12	-	19	16	12	-	19	16	12	-	19	16	12	-	19	16	12	-	17	15	11	-	
	kW	3.94	4.02	4.15	-	4.24	4.33	4.47	-	4.50	4.60	4.75	-	4.73	4.84	4.99	-	4.93	5.04	5.20	-	5.10	5.21	5.38	-	
	Amps	12.4	12.6	12.9	-	13.2	13.4	13.8	-	14.1	14.4	14.8	-	14.9	15.2	15.6	-	15.7	16.0	16.5	-	16.5	16.8	17.3	-	
	1950	HI PR	241	260	274	-	271	291	308	-	308	331	350	-	351	377	398	-	394	424	448	-	436	469	495	-
LO PR		106	113	123	-	112	119	130	-	116	124	135	-	122	130	142	-	128	136	149	-	133	141	154	-	
MBh		52.2	54.2	59.3	-	51.0	52.9	58.0	-	49.8	51.6	56.6	-	48.6	50.4	55.2	-	46.2	47.9	52.4	-	42.8	44.3	48.6	-	
S/T		0.67	0.56	0.39	-	0.69	0.58	0.40	-	0.71	0.59	0.41	-	0.73	0.61	0.42	-	0.76	0.64	0.44	-	0.77	0.64	0.44	-	
ΔT		19	16	12	-	19	16	13	-	19	16	13	-	19	17	13	-	19	16	12	-	18	15	12	-	
kW		3.85	3.93	4.05	-	4.14	4.23	4.36	-	4.39	4.49	4.63	-	4.62	4.72	4.87	-	4.81	4.91	5.07	-	4.97	5.08	5.25	-	
Amps		12.1	12.3	12.6	-	12.9	13.1	13.5	-	13.8	14.0	14.4	-	14.5	14.8	15.3	-	15.3	15.6	16.1	-	16.1	16.4	16.9	-	
HI PR		234	252	266	-	263	283	298	-	299	321	339	-	340	366	386	-	383	412	435	-	423	455	480	-	
LO PR		103	109	120	-	109	116	126	-	113	120	131	-	119	126	138	-	124	132	144	-	129	137	149	-	
1710		MBh	59.3	61.0	66.1	70.9	57.9	59.6	64.5	69.3	56.5	58.2	63.0	67.6	55.2	56.8	61.5	66.0	52.4	53.9	58.4	62.7	48.5	50.0	54.1	58.1
		S/T	0.83	0.74	0.56	0.36	0.86	0.77	0.58	0.37	0.88	0.79	0.60	0.38	0.91	0.81	0.61	0.40	0.94	0.84	0.64	0.41	0.95	0.85	0.64	0.41
		ΔT	21	19	16	11	21	19	16	11	21	19	16	11	21	19	16	11	21	19	16	11	19	18	15	10
	kW	4.01	4.09	4.22	4.35	4.31	4.40	4.54	4.68	4.58	4.67	4.82	4.98	4.81	4.92	5.08	5.24	5.01	5.12	5.29	5.47	5.18	5.30	5.47	5.66	
	Amps	12.5	12.8	13.1	13.5	13.4	13.6	14.0	14.4	14.3	14.6	15.0	15.5	15.1	15.4	15.9	16.4	15.9	16.3	16.7	17.3	16.7	17.1	17.6	18.2	
	HI PR	246	265	280	292	276	297	314	327	314	338	357	372	358	385	406	424	402	433	457	477	445	478	505	527	
	LO PR	108	115	126	134	114	122	133	141	119	126	138	147	125	133	145	154	131	139	152	162	135	144	157	167	
	MBh	57.6	59.3	64.2	68.9	56.2	57.9	62.7	67.3	54.9	56.5	61.2	65.7	53.6	55.1	59.7	64.1	50.9	52.4	56.7	60.8	47.1	48.5	52.5	56.4	
	S/T	0.79	0.71	0.53	0.34	0.82	0.73	0.55	0.36	0.84	0.75	0.57	0.37	0.87	0.77	0.59	0.38	0.90	0.80	0.61	0.39	0.91	0.81	0.61	0.39	
	ΔT	21	20	16	11	22	20	16	11	22	20	16	11	22	20	16	11	22	20	16	11	20	19	15	10	
	kW	3.97	4.06	4.18	4.31	4.27	4.36	4.50	4.65	4.54	4.64	4.78	4.94	4.77	4.88	5.03	5.20	4.97	5.08	5.25	5.42	5.14	5.26	5.43	5.61	
	Amps	12.4	12.7	13.0	13.4	13.3	13.5	13.9	14.3	14.2	14.5	14.9	15.4	15.0	15.3	15.7	16.3	15.8	16.1	16.6	17.2	16.6	17.0	17.5	18.0	
HI PR	244	262	277	289	273	294	311	324	311	335	353	369	354	381	402	420	398	429	453	472	440	474	500	522		
LO PR	107	114	124	133	113	120	131	140	118	125	137	146	124	131	144	153	130	138	150	160	134	143	156	166		
MBh	53.1	54.7	59.2	63.6	51.9	53.4	57.8	62.1	50.7	52.2	56.5	60.6	49.4	50.9	55.1	59.1	47.0	48.3	52.3	56.2	43.5	44.8	48.5	52.0		
S/T	0.76	0.68	0.52	0.33	0.79	0.71	0.53	0.34	0.81	0.72	0.55	0.35	0.83	0.75	0.57	0.36	0.87	0.77	0.59	0.38	0.87	0.78	0.59	0.38		
ΔT	22	20	16	11	22	20	17	11	22	20	17	11	22	20	17	11	22	20	17	11	20	19	15	11		
kW	3.88	3.96	4.08	4.21	4.17	4.26	4.39	4.53	4.43	4.52	4.67	4.82	4.66	4.76	4.91	5.07	4.85	4.95	5.11	5.28	5.01	5.12	5.29	5.47		
Amps	12.2	12.4	12.7	13.1	13.0	13.2	13.6	14.0	13.9	14.1	14.5	15.0	14.7	15.0	15.4	15.9	15.4	15.8	16.2	16.7	16.2	16.6	17.0	17.6		
HI PR	236	254	269	280	265	285	301	314	302	325	343	357	344	370	390	407	386	416	439	458	427	460	485	506		
LO PR	104	111	121	129	110	117	128	136	114	121	133	141	120	128	139	148	126	134	146	155	130	138	151	161		

IDB = Entering Indoor Dry Bulb Temperature  
 High & low pressures are measured at the liquid & suction service ports.  
 Shaded area reflects ACCA (TV) conditions  
 kW = Total system power  
 Amps: Unit amps (comp.+ evaporator + condenser fan motors)



EXPANDED COOLING DATA — CPH060 (cont.)

IDB	AIRFLOW	OUTDOOR AMBIENT TEMPERATURE												ENTERING INDOOR WET BULB TEMPERATURE												
		65°F				75°F				85°F				95°F				105°F				115°F				
		59	63	67	71	59	63	67	71	59	63	67	71	59	63	67	71	59	63	67	71	59	63	67	71	
2190	MBh	60.3	61.7	65.9	70.4	58.9	60.2	64.3	68.8	57.5	58.8	62.8	67.2	56.1	57.4	61.3	65.5	53.3	54.5	58.2	62.2	49.4	50.5	53.9	57.7	
	S/T	0.91	0.85	0.69	0.52	0.94	0.88	0.72	0.54	0.96	0.90	0.74	0.55	1.00	0.93	0.76	0.57	1.00	0.97	0.79	0.59	1.00	1.00	0.80	0.59	
	ΔT	23	22	19	15	23	22	19	15	23	22	19	16	24	22	20	16	22	22	19	15	21	21	18	14	
	kW	4.04	4.12	4.25	4.38	4.34	4.43	4.58	4.72	4.61	4.71	4.86	5.02	4.85	4.96	5.12	5.29	5.05	5.16	5.33	5.51	5.23	5.34	5.52	5.71	
	HI PR	249	267	282	295	279	300	317	331	317	341	360	376	361	389	411	428	406	437	462	482	449	483	510	532	
	LO PR	109	116	127	135	116	123	134	143	120	128	139	148	126	134	146	156	132	141	153	163	137	145	159	169	
	MBh	58.6	59.9	64.0	68.4	57.2	58.5	62.5	66.8	55.9	57.1	61.0	65.2	54.5	55.7	59.5	63.6	51.8	52.9	56.5	60.4	48.0	49.0	52.4	56.0	
	S/T	0.87	0.81	0.66	0.49	0.90	0.84	0.68	0.51	0.92	0.86	0.70	0.52	0.95	0.89	0.72	0.54	0.99	0.92	0.75	0.56	0.99	0.93	0.76	0.57	
	ΔT	24	23	20	16	24	23	20	16	24	23	20	16	24	23	20	16	24	23	20	16	22	22	19	15	
	kW	4.01	4.09	4.22	4.35	4.31	4.40	4.54	4.69	4.58	4.67	4.82	4.98	4.81	4.92	5.08	5.24	5.01	5.12	5.29	5.47	5.19	5.30	5.47	5.66	
Amps	12.5	12.8	13.1	13.5	13.4	13.6	14.0	14.4	14.3	14.6	15.0	15.5	15.1	15.4	15.9	16.4	15.9	16.3	16.7	17.3	16.8	17.1	17.6	18.2		
HI PR	246	265	280	292	276	297	314	327	314	338	357	372	358	385	407	424	402	433	457	477	445	478	505	527		
LO PR	108	115	126	134	114	122	133	141	119	126	138	147	125	133	145	154	131	139	152	162	135	144	157	167		
1950	MBh	54.1	55.3	59.0	63.1	52.8	54.0	57.7	61.6	51.6	52.7	56.3	60.2	50.3	51.4	54.9	58.7	47.8	48.8	52.2	55.8	44.3	45.2	48.3	51.7	
	S/T	0.83	0.78	0.64	0.48	0.86	0.81	0.66	0.49	0.89	0.83	0.68	0.51	0.92	0.86	0.70	0.52	0.95	0.89	0.73	0.54	0.96	0.90	0.73	0.55	
	ΔT	24	23	20	16	25	24	20	16	25	24	20	16	25	24	21	16	24	23	20	16	23	22	19	15	
	kW	3.91	3.99	4.12	4.24	4.21	4.29	4.43	4.57	4.46	4.56	4.71	4.86	4.69	4.80	4.95	5.11	4.89	5.00	5.16	5.33	5.06	5.17	5.34	5.52	
	Amps	12.3	12.5	12.8	13.2	13.1	13.3	13.7	14.1	14.0	14.3	14.7	15.1	14.8	15.1	15.5	16.0	15.6	15.9	16.3	16.9	16.4	16.7	17.2	17.7	
	HI PR	239	257	271	283	268	288	304	317	305	328	346	361	347	373	394	411	390	420	444	463	431	464	490	511	
	LO PR	105	112	122	130	111	118	129	137	115	123	134	143	121	129	141	150	127	135	147	157	131	140	152	162	
	1710	MBh	61.4	62.6	65.6	69.9	60.0	61.1	64.0	68.3	58.5	59.7	62.5	66.7	57.1	58.2	61.0	65.1	54.3	55.3	57.9	61.8	50.3	51.2	53.7	57.2
		S/T	0.95	0.92	0.83	0.67	0.99	0.95	0.86	0.70	1.00	0.98	0.88	0.71	1.00	1.00	0.91	0.74	1.00	1.00	0.94	0.77	1.00	1.00	0.95	0.77
		ΔT	25	24	23	20	25	24	23	20	25	24	23	20	24	24	23	20	23	23	23	20	21	22	21	19
kW		4.07	4.15	4.28	4.42	4.38	4.47	4.61	4.76	4.65	4.75	4.90	5.06	4.89	5.00	5.16	5.33	5.10	5.21	5.38	5.56	5.27	5.39	5.57	5.75	
Amps		12.7	13.0	13.3	13.7	13.6	13.8	14.2	14.6	14.5	14.8	15.2	15.7	15.4	15.7	16.1	16.6	16.2	16.5	17.0	17.6	17.0	17.4	17.9	18.5	
HI PR		251	270	285	298	282	303	320	334	320	345	364	380	365	393	415	433	411	442	467	487	454	488	515	538	
LO PR		110	117	128	137	117	124	135	144	121	129	141	150	127	135	148	158	133	142	155	165	138	147	160	171	
MBh		59.6	60.8	63.6	67.9	58.2	59.4	62.2	66.3	56.8	57.9	60.7	64.7	55.5	56.5	59.2	63.2	52.7	53.7	56.2	60.0	48.8	49.7	52.1	55.6	
S/T		0.91	0.88	0.79	0.64	0.94	0.91	0.82	0.66	0.96	0.93	0.84	0.68	1.00	0.96	0.87	0.70	1.00	1.00	0.90	0.73	1.00	1.00	0.91	0.74	
ΔT		26	25	24	21	26	25	24	21	26	25	24	21	26	26	24	21	25	25	24	21	23	23	22	19	
kW	4.04	4.12	4.25	4.38	4.34	4.43	4.58	4.72	4.61	4.71	4.86	5.02	4.85	4.96	5.12	5.29	5.05	5.16	5.33	5.51	5.23	5.34	5.52	5.71		
Amps	12.6	12.9	13.2	13.6	13.5	13.7	14.1	14.5	14.4	14.7	15.1	15.6	15.2	15.6	16.0	16.5	16.1	16.4	16.9	17.4	16.9	17.2	17.7	18.3		
HI PR	249	267	282	295	279	300	317	331	317	341	360	376	361	389	411	428	406	437	462	482	449	483	510	532		
LO PR	109	116	127	135	116	123	134	143	120	128	139	148	126	134	146	156	132	141	153	163	137	145	159	169		
MBh	55.0	56.1	58.7	62.7	53.7	54.8	57.4	61.2	52.5	53.5	56.0	59.8	51.2	52.2	54.6	58.3	48.6	49.6	51.9	55.4	45.0	45.9	48.1	51.3		
S/T	0.87	0.84	0.76	0.62	0.91	0.87	0.79	0.64	0.93	0.90	0.81	0.66	0.96	0.93	0.84	0.68	1.00	0.96	0.87	0.70	1.00	0.97	0.87	0.71		
ΔT	26	25	24	21	26	26	24	21	26	26	24	21	26	26	25	21	26	26	24	21	24	24	23	20		
kW	3.94	4.02	4.15	4.28	4.24	4.33	4.46	4.61	4.50	4.60	4.74	4.90	4.73	4.83	4.99	5.16	4.93	5.04	5.20	5.37	5.10	5.21	5.38	5.56		
Amps	12.3	12.6	12.9	13.3	13.2	13.4	13.8	14.2	14.1	14.4	14.8	15.2	14.9	15.2	15.6	16.1	15.7	16.0	16.5	17.0	16.5	16.8	17.3	17.9		
HI PR	241	259	274	286	271	291	307	321	308	331	350	365	350	377	398	415	394	424	448	467	436	469	495	516		
LO PR	106	113	123	131	112	119	130	139	116	124	135	144	122	130	142	151	128	136	149	159	133	141	154	164		

kW = Total system power  
Amps: Unit amps (comp.+ evaporator + condenser fan motors)

Shaded area reflects AHRI (TVSA) conditions

IDB = Entering Indoor Dry Bulb Temperature  
High & low pressures are measured at the liquid & suction service ports.

EXPANDED COOLING DATA — CPH072

IDB	AIRFLOW	OUTDOOR AMBIENT TEMPERATURE																									
		65				75				85				95				105				115					
		59	63	67	71	59	63	67	71	59	63	67	71	59	63	67	71	59	63	67	71	59	63	67	71		
70	2400	MBh	68.6	71.1	77.9	-	67.0	69.4	76.0	-	65.4	67.8	74.2	-	63.8	66.1	72.4	-	60.6	62.8	68.8	-	56.1	58.2	63.7	-	
		S/T	0.71	0.59	0.41	-	0.74	0.62	0.43	-	0.76	0.63	0.44	-	0.78	0.65	0.45	-	0.81	0.68	0.47	-	0.82	0.68	0.47	-	
	2150	ΔT	19	16	12	-	19	16	12	-	19	16	12	-	19	17	13	-	19	16	12	-	18	15	12	-	
		kW	5.05	5.15	5.30	-	5.41	5.52	5.69	-	5.73	5.85	6.03	-	6.01	6.14	6.33	-	6.25	6.39	6.59	-	6.46	6.60	6.81	-	
	1875	Amps	16.9	17.2	17.6	-	17.9	18.2	18.7	-	19.1	19.4	19.9	-	20.0	20.4	20.9	-	21.0	21.4	22.0	-	22.0	22.4	23.0	-	
		HI PR	239	258	272	-	269	289	305	-	306	329	347	-	348	374	395	-	391	421	445	-	433	465	492	-	
	75	2400	LO PR	107	114	124	-	113	120	131	-	117	125	136	-	123	131	143	-	129	137	150	-	134	142	155	-
			MBh	67.5	70.0	76.7	-	66.0	68.4	74.9	-	64.4	66.8	73.1	-	62.8	65.1	71.4	-	59.7	61.9	67.8	-	55.3	57.3	62.8	-
		2150	S/T	0.68	0.57	0.39	-	0.71	0.59	0.41	-	0.72	0.61	0.42	-	0.75	0.62	0.43	-	0.78	0.65	0.45	-	0.78	0.65	0.45	-
			ΔT	20	17	13	-	20	17	13	-	20	17	13	-	20	17	13	-	20	17	13	-	19	16	12	-
		1875	kW	5.02	5.12	5.27	-	5.38	5.49	5.66	-	5.70	5.82	6.00	-	5.98	6.11	6.29	-	6.22	6.35	6.55	-	6.42	6.56	6.77	-
			Amps	16.9	17.2	17.6	-	17.8	18.2	18.6	-	19.0	19.3	19.8	-	20.0	20.3	20.8	-	20.9	21.3	21.9	-	21.9	22.3	22.9	-
75		2400	HI PR	238	256	270	-	267	287	303	-	303	327	345	-	346	372	393	-	389	418	442	-	430	462	488	-
			LO PR	106	113	123	-	112	119	130	-	116	124	135	-	122	130	142	-	128	136	149	-	133	141	154	-
		2150	MBh	62.3	64.6	70.8	-	60.9	63.1	69.2	-	59.4	61.6	67.5	-	58.0	60.1	65.9	-	55.1	57.1	62.6	-	51.0	52.9	58.0	-
			S/T	0.66	0.55	0.38	-	0.68	0.57	0.39	-	0.70	0.58	0.40	-	0.72	0.60	0.42	-	0.75	0.63	0.43	-	0.76	0.63	0.44	-
		1875	ΔT	20	17	13	-	20	18	13	-	20	18	13	-	21	18	13	-	21	18	13	-	19	16	12	-
			kW	4.91	5.01	5.15	-	5.26	5.37	5.53	-	5.57	5.68	5.86	-	5.84	5.96	6.15	-	6.07	6.20	6.39	-	6.27	6.40	6.60	-
	75	2400	Amps	16.5	16.8	17.2	-	17.5	17.8	18.2	-	18.6	18.9	19.4	-	19.5	19.9	20.4	-	20.5	20.9	21.4	-	21.4	21.8	22.4	-
			HI PR	231	248	262	-	259	278	294	-	294	317	334	-	335	361	381	-	377	406	429	-	417	448	473	-
		2150	LO PR	103	109	120	-	109	116	126	-	113	120	131	-	119	126	138	-	124	132	144	-	129	137	149	-
			MBh	69.7	71.8	77.7	83.4	68.1	70.1	75.9	81.5	66.5	68.4	74.1	79.5	64.9	66.8	72.3	77.6	61.6	63.4	68.7	73.7	57.1	58.8	63.6	68.3
		1875	S/T	0.81	0.72	0.55	0.35	0.84	0.75	0.57	0.37	0.86	0.77	0.58	0.37	0.89	0.79	0.60	0.39	0.92	0.82	0.62	0.40	0.93	0.83	0.63	0.40
			ΔT	22	20	16	11	22	20	17	11	22	20	17	11	22	20	17	11	22	20	16	11	20	19	15	11
75		2400	kW	5.09	5.19	5.34	5.50	5.45	5.56	5.73	5.91	5.78	5.90	6.08	6.27	6.06	6.19	6.38	6.58	6.30	6.44	6.64	6.85	6.51	6.65	6.86	7.08
			Amps	17.1	17.3	17.8	18.2	18.0	18.4	18.8	19.3	19.2	19.5	20.0	20.6	20.2	20.6	21.1	21.7	21.2	21.6	22.2	22.8	22.2	22.6	23.2	23.9
		2150	HI PR	242	260	275	287	271	292	308	322	309	332	351	366	352	378	399	417	395	426	449	469	437	470	497	518
			LO PR	108	115	125	133	114	121	132	141	118	126	138	147	124	132	145	154	130	139	151	161	135	144	157	167
		1875	MBh	68.7	70.7	76.6	82.2	67.1	69.1	74.8	80.3	65.5	67.4	73.0	78.3	63.9	65.8	71.2	76.4	60.7	62.5	67.7	72.6	56.2	57.9	62.7	67.3
			S/T	0.78	0.69	0.52	0.34	0.80	0.72	0.54	0.35	0.82	0.74	0.56	0.36	0.85	0.76	0.58	0.37	0.88	0.79	0.60	0.38	0.89	0.80	0.60	0.39
	75	2400	ΔT	23	21	17	12	23	21	17	12	23	21	17	12	23	21	18	12	23	21	17	12	21	20	16	11
			kW	5.06	5.16	5.31	5.47	5.42	5.53	5.70	5.88	5.75	5.86	6.04	6.23	6.03	6.15	6.35	6.55	6.27	6.40	6.60	6.81	6.48	6.61	6.82	7.04
		2150	Amps	17.0	17.3	17.7	18.2	18.0	18.3	18.7	19.3	19.1	19.5	19.9	20.5	20.1	20.5	21.0	21.6	21.1	21.5	22.0	22.7	22.1	22.5	23.1	23.8
			HI PR	240	258	273	285	269	290	306	319	307	330	348	363	349	376	397	414	393	423	446	465	434	467	493	514
		1875	LO PR	107	114	124	133	113	120	131	140	118	125	137	146	124	131	144	153	130	138	150	160	134	143	156	166
			MBh	63.4	65.3	70.7	75.8	61.9	63.8	69.0	74.1	60.5	62.2	67.4	72.3	59.0	60.7	65.7	70.5	56.0	57.7	62.4	67.0	51.9	53.4	57.8	62.1
75		2400	S/T	0.75	0.67	0.51	0.33	0.77	0.69	0.52	0.34	0.79	0.71	0.54	0.35	0.82	0.73	0.56	0.36	0.85	0.76	0.58	0.37	0.86	0.77	0.58	0.37
			ΔT	23	21	18	12	24	22	18	12	24	22	18	12	24	22	18	12	24	22	18	12	22	20	16	11
		2150	kW	4.95	5.05	5.19	5.35	5.30	5.41	5.57	5.74	5.61	5.73	5.90	6.09	5.89	6.01	6.19	6.39	6.12	6.25	6.44	6.65	6.32	6.46	6.66	6.87
			Amps	16.6	16.9	17.3	17.8	17.6	17.9	18.3	18.9	18.7	19.1	19.5	20.1	19.7	20.0	20.5	21.1	20.6	21.0	21.6	22.2	21.6	22.0	22.6	23.2
		1875	HI PR	233	251	265	276	261	281	297	310	297	320	338	352	339	364	385	401	381	410	433	452	421	453	478	499
			LO PR	104	111	121	129	110	117	128	136	114	121	133	141	120	128	139	148	126	134	146	155	130	138	151	161

IDB = Entering Indoor Dry Bulb Temperature  
 High and low pressures are measured at the liquid and suction access fittings.  
 Shaded area reflects ACCA (TVA) Rating Conditions  
 kW = Total system power  
 Amps: Unit amps (comp. + evaporator + condenser fan motors)



EXPANDED COOLING DATA — CPH072 (CONT.)

IDB	AIRFLOW	OUTDOOR AMBIENT TEMPERATURE																									
		65				75				85				95				105				115					
		59	63	67	71	59	63	67	71	59	63	67	71	59	63	67	71	59	63	67	71	59	63	67	71		
80	2400	MBh	71.0	72.5	77.5	82.8	69.3	70.8	75.7	80.9	67.7	69.1	73.9	79.0	66.0	67.5	72.1	77.0	62.7	64.1	68.5	73.2	58.1	59.4	63.4	67.8	
		S/T	0.89	0.83	0.68	0.51	0.92	0.86	0.70	0.53	0.94	0.89	0.72	0.54	0.97	0.91	0.74	0.56	1.00	0.95	0.77	0.58	1.00	0.96	0.78	0.58	
	2150	ΔT	24	23	20	16	24	23	20	16	25	24	21	16	25	24	21	16	24	23	20	16	22	22	19	15	
		kW	5.13	5.23	5.38	5.54	5.49	5.61	5.78	5.96	5.82	5.94	6.12	6.32	6.11	6.24	6.43	6.64	6.35	6.49	6.69	6.91	6.57	6.71	6.92	7.14	
	1875	Amps	17.2	17.5	17.9	18.4	18.2	18.5	18.9	19.5	19.3	19.7	20.2	20.8	20.3	20.7	21.3	21.9	21.3	21.7	22.3	23.0	22.3	22.8	23.4	24.1	
		Hi Pr	244	263	278	290	274	295	312	325	312	336	354	370	355	382	404	421	399	430	454	473	441	475	502	523	
	85	2400	Lo Pr	109	116	127	135	115	123	134	142	120	127	139	148	126	134	146	156	132	140	153	163	136	145	158	169
			MBh	69.9	71.4	76.3	81.6	68.3	69.8	74.6	79.7	66.7	68.1	72.8	77.8	65.0	66.5	71.0	75.9	61.8	63.1	67.5	72.1	57.2	58.5	62.5	66.8
		2150	S/T	0.85	0.80	0.65	0.49	0.88	0.83	0.67	0.50	0.90	0.85	0.69	0.52	0.93	0.87	0.71	0.53	0.97	0.91	0.74	0.55	0.98	0.92	0.75	0.56
			ΔT	25	24	21	17	26	25	21	17	26	25	21	17	26	25	22	17	26	25	21	17	24	23	20	16
		1875	kW	5.10	5.20	5.35	5.52	5.47	5.58	5.75	5.92	5.79	5.91	6.09	6.28	6.08	6.20	6.40	6.60	6.32	6.45	6.66	6.87	6.53	6.67	6.88	7.10
			Amps	17.1	17.4	17.8	18.3	18.1	18.4	18.9	19.4	19.2	19.6	20.1	20.7	20.2	20.6	21.1	21.8	21.2	21.6	22.2	22.9	22.2	22.6	23.3	24.0
88		2400	Hi Pr	243	261	276	288	272	293	309	323	310	333	352	367	353	379	401	418	397	427	451	470	438	472	498	519
			Lo Pr	108	115	126	134	114	122	133	141	119	126	138	147	125	133	145	154	131	139	152	162	135	144	157	167
		2150	MBh	64.5	65.9	70.4	75.3	63.0	64.4	68.8	73.6	61.5	62.9	67.2	71.8	60.0	61.3	65.5	70.1	57.0	58.3	62.3	66.6	52.8	54.0	57.7	61.6
			S/T	0.82	0.77	0.63	0.47	0.85	0.80	0.65	0.48	0.87	0.82	0.67	0.50	0.90	0.84	0.69	0.51	0.93	0.88	0.71	0.53	0.94	0.88	0.72	0.54
		1875	ΔT	26	25	22	17	26	25	22	17	26	25	22	18	26	25	22	18	26	25	22	17	24	23	20	16
			kW	4.99	5.08	5.23	5.39	5.34	5.45	5.61	5.78	5.66	5.77	5.95	6.13	5.93	6.06	6.24	6.44	6.17	6.30	6.50	6.70	6.37	6.51	6.71	6.93
	91	2400	Amps	16.8	17.0	17.4	17.9	17.7	18.0	18.5	19.0	18.8	19.2	19.7	20.2	19.8	20.2	20.7	21.3	20.8	21.2	21.7	22.4	21.7	22.1	22.7	23.4
			Hi Pr	235	253	267	279	264	284	300	313	300	323	341	356	342	368	389	405	385	414	437	456	425	458	483	504
		2150	Lo Pr	105	112	122	130	111	118	129	137	115	123	134	143	121	129	141	150	127	135	147	157	131	140	152	162
			MBh	72.2	73.6	77.1	82.2	70.5	71.9	75.3	80.3	68.8	70.2	73.5	78.4	67.2	68.5	71.7	76.5	63.8	65.0	68.1	72.7	59.1	60.2	63.1	67.3
		1875	S/T	0.93	0.90	0.81	0.66	0.96	0.93	0.84	0.68	0.99	0.95	0.86	0.70	1.00	0.99	0.89	0.72	1.00	1.00	0.92	0.75	1.00	1.00	0.93	0.76
			ΔT	26	25	24	21	26	26	24	21	26	26	24	21	26	26	24	21	24	25	24	21	23	23	22	19
94		2400	kW	5.16	5.27	5.42	5.59	5.54	5.65	5.82	6.00	5.87	5.99	6.17	6.37	6.16	6.29	6.48	6.69	6.40	6.54	6.75	6.96	6.62	6.76	6.97	7.20
			Amps	17.3	17.6	18.0	18.5	18.3	18.6	19.1	19.6	19.5	19.8	20.3	20.9	20.5	20.9	21.4	22.0	21.5	21.9	22.5	23.2	22.5	22.9	23.5	24.3
		2150	Hi Pr	247	266	280	292	277	298	315	328	315	339	358	373	359	386	408	425	403	434	458	478	446	480	507	528
			Lo Pr	110	117	128	136	116	124	135	144	121	129	140	150	127	135	147	157	133	142	155	165	138	146	160	170
		1875	MBh	71.1	72.5	75.9	81.0	69.5	70.8	74.2	79.1	67.8	69.1	72.4	77.3	66.2	67.5	70.6	75.4	62.9	64.1	67.1	71.6	58.2	59.4	62.2	66.3
			S/T	0.89	0.86	0.78	0.63	0.92	0.89	0.80	0.65	0.95	0.91	0.82	0.67	0.98	0.94	0.85	0.69	1.00	0.98	0.88	0.72	1.00	0.99	0.89	0.72
	97	2400	ΔT	27	27	25	22	27	27	26	22	27	27	26	22	28	27	26	22	27	27	25	22	25	25	24	21
			kW	5.14	5.24	5.39	5.56	5.51	5.62	5.79	5.97	5.83	5.96	6.14	6.33	6.12	6.25	6.45	6.65	6.37	6.50	6.71	6.93	6.58	6.72	6.94	7.16
		2150	Amps	17.2	17.5	17.9	18.4	18.2	18.5	19.0	19.5	19.4	19.7	20.2	20.8	20.4	20.8	21.3	21.9	21.4	21.8	22.4	23.0	22.4	22.8	23.4	24.1
			Hi Pr	245	264	278	290	275	296	312	326	313	337	355	371	356	383	405	422	401	431	455	475	443	476	503	525
		1875	Lo Pr	109	116	127	135	116	123	134	143	120	128	139	148	126	134	146	156	132	141	153	163	137	145	159	169
			MBh	65.7	66.9	70.1	74.8	64.1	65.4	68.5	73.0	62.6	63.8	66.8	71.3	61.1	62.3	65.2	69.6	58.0	59.1	61.9	66.1	53.7	54.8	57.4	61.2
100		2400	S/T	0.86	0.83	0.75	0.61	0.89	0.86	0.78	0.63	0.91	0.88	0.80	0.65	0.94	0.91	0.82	0.67	0.98	0.94	0.85	0.69	0.99	0.95	0.86	0.70
			ΔT	28	27	26	22	28	28	26	23	28	28	26	23	28	28	26	23	28	27	25	22	26	26	24	21
		2150	kW	5.02	5.12	5.27	5.43	5.38	5.49	5.66	5.83	5.70	5.82	5.99	6.18	5.98	6.10	6.29	6.49	6.22	6.35	6.55	6.76	6.42	6.56	6.77	6.98
			Amps	16.9	17.2	17.6	18.0	17.8	18.2	18.6	19.1	19.0	19.3	19.8	20.4	19.9	20.3	20.8	21.4	20.9	21.3	21.9	22.5	21.9	22.3	22.9	23.6
		1875	Hi Pr	238	256	270	282	267	287	303	316	303	326	345	359	345	372	393	409	389	418	442	461	429	462	488	509
			Lo Pr	106	113	123	131	112	119	130	139	116	124	135	144	122	130	142	151	128	136	149	159	133	141	154	164

IDB = Entering Indoor Dry Bulb Temperature  
 High and low pressures are measured at the liquid and suction access fittings.  
 Shaded area reflects AHRI (TVA) Rating Conditions  
 Amps: Unit amps (comp. + evaporator + condenser fan motors)  
 kW = Total system power

**DIMENSIONS**

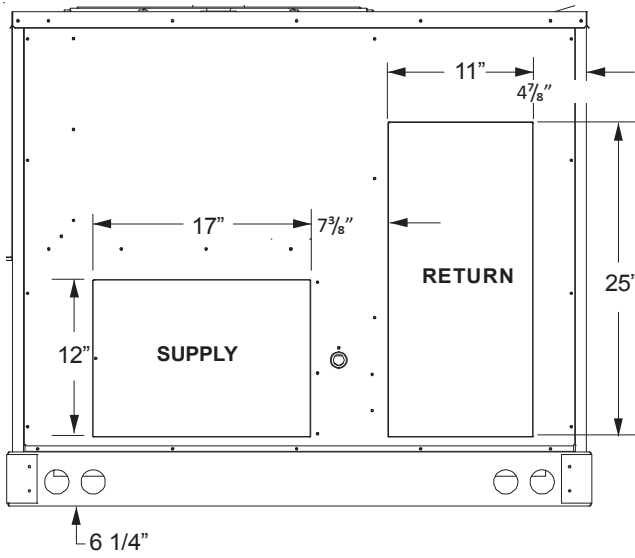
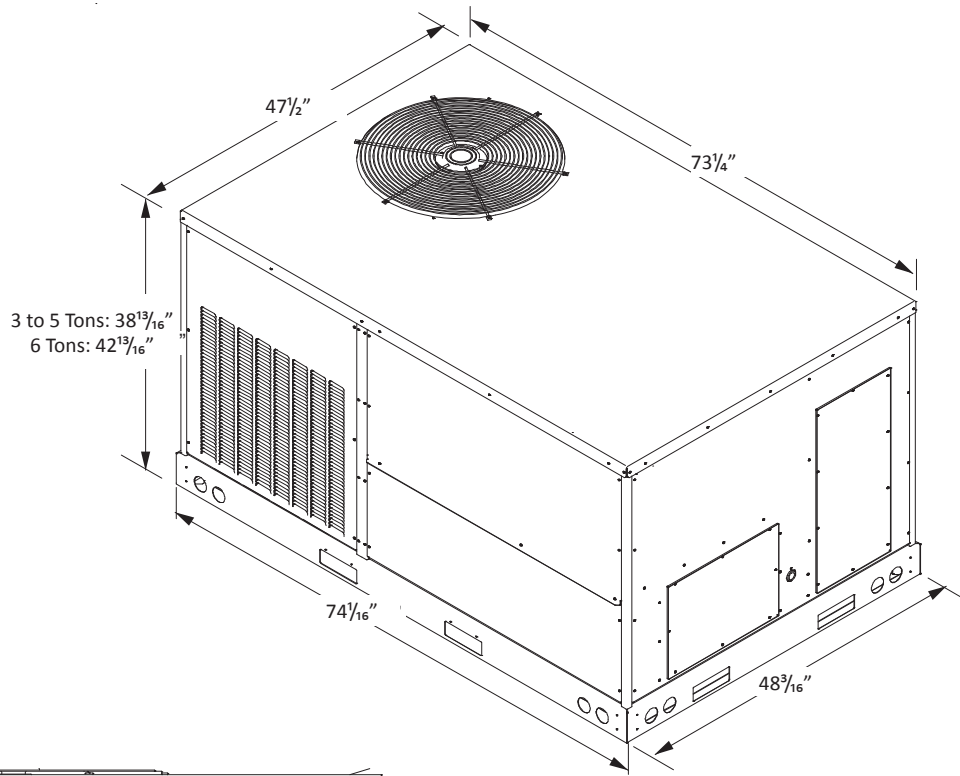

Horizontal Discharge

## UNIT CLEARANCES

Maintain an adequate clearance around the unit for safety, service, maintenance, and proper unit operation. Leave a total clearance of 75" on the main control panel side of the unit for possible removal of fan shaft, coil, electric heat, and gas furnace. Leave a clearance of 48" on all other sides of the unit for possible compressor removal or service access, and to ensure proper ventilation and condenser airflow. Do not install the unit beneath any obstruction. Install the unit away from all building exhausts to inhibit ingestion of exhaust air into the unit's fresh-air intake.

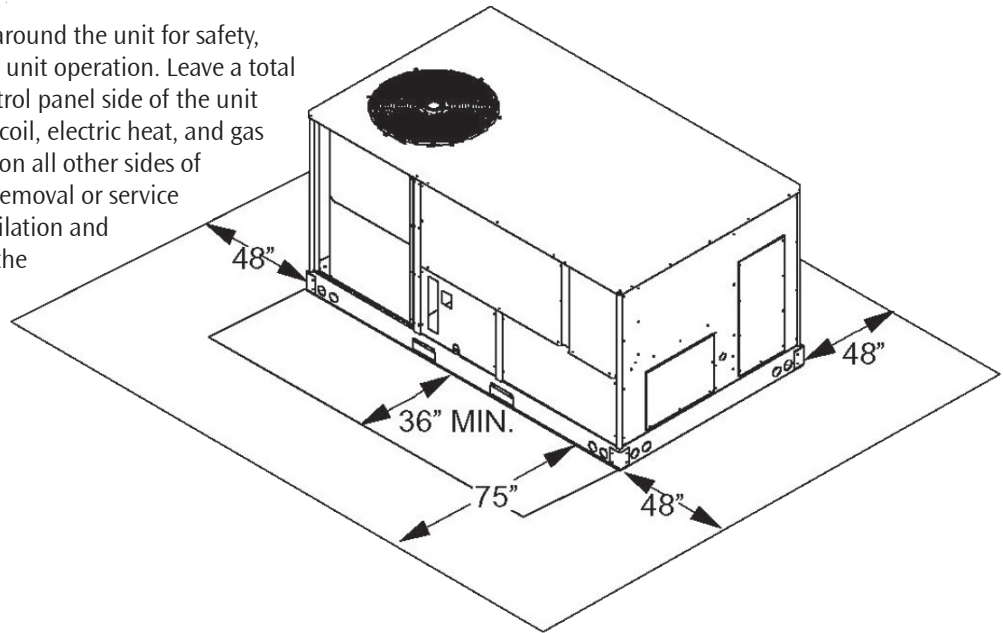

## ELECTRICAL ENTRANCE LOCATIONS

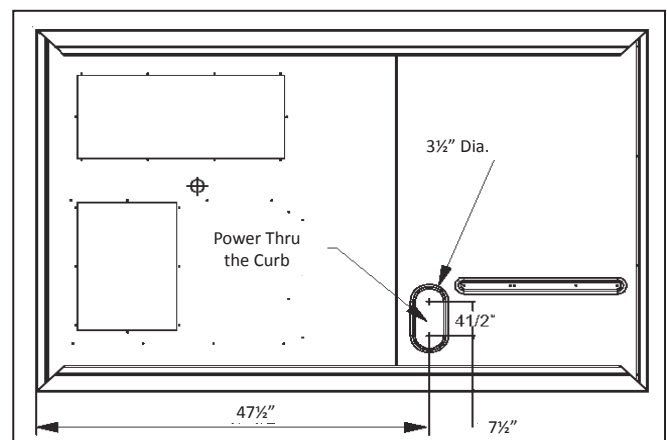
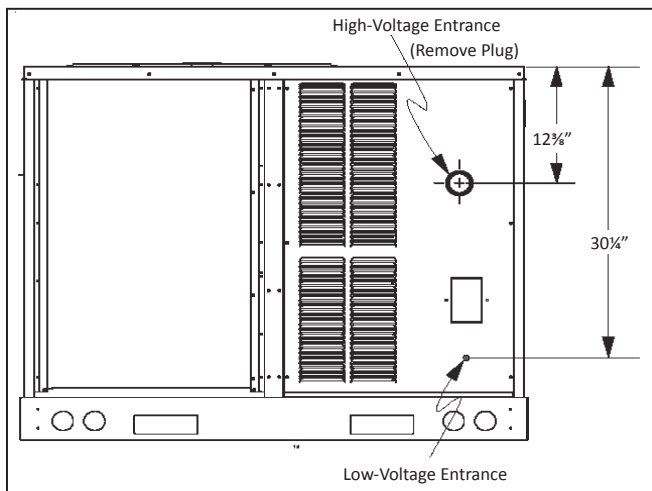

## ROOF CURB INSTALLATION — RIGGING

Provisions for forks have been included in the unit base frame. No other fork locations are approved.

- Unit must be lifted by the four lifting holes located at the base frame corners.
- Lifting cables should be attached to the unit with shackles.
- The distance between the crane hook and the top of the unit must not be less than 60”.
- Two spreader bars must span over the unit to prevent damage to the cabinet by the lift cables. Spreader bars must be of sufficient length so that cables do not come in contact with the unit during transport. Remove wood struts mounted beneath unit base frame before setting unit on roof curb. These struts are intended to protect unit base frame from fork lift damage. To remove the struts, extract the sheet metal retainers and pull the struts through the base of the unit. Refer to rigging label on the unit.

**Important:** If using bottom discharge with roof curb, duct-work should be attached to the curb prior to installing the unit. Duct-work dimensions are shown in Roof Curb Installation Instructions Manual.

Refer to the Roof Curb Installation Instructions for proper curb installation. Curbing must be installed in compliance with the National Roofing Contractors Association Manual.

Lower unit carefully onto roof mounting curb. While rigging the unit, the center of gravity will cause the condenser end to be lower than the supply air end.

Bring condenser end of unit into alignment with the curb. With condenser end of the unit resting on curb member and using curb as a fulcrum, lower opposite end of the unit until entire unit is seated on the curb. When a rectangular cantilever curb is used, take care to center the unit. Check for proper alignment and orientation of supply and return openings with duct.

To assist in determining rigging requirements, unit weights are shown below.



### CORNER & CENTER-OF-GRAVITY LOCATIONS

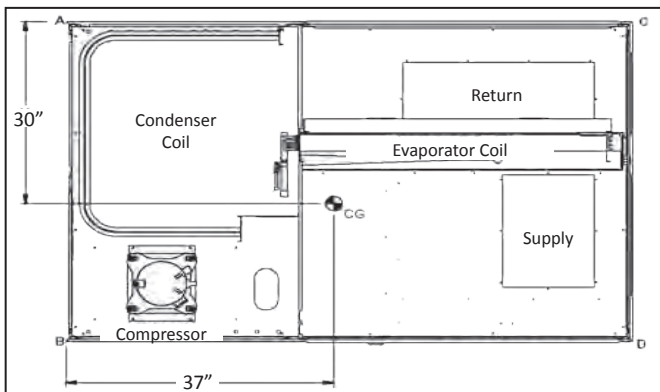

UNIT WEIGHTS	3-TON WEIGHTS	4-TON WEIGHTS	5-TON WEIGHTS	6-TON WEIGHTS
Corner Weight (A)	125	125	140	145
Corner Weight (B)	170	170	180	205
Corner Weight (C)	105	105	110	125
Corner Weight (D)	145	145	135	175
Unit Shipping Weight	570	570	590	675
Unit Operating Weight	545	545	565	650

**Note:** Weights are calculated without accessories installed.

## ROOF CURB INSTALLATION (CONT.)

Curb installations must comply with local codes and should follow the established guidelines of the National Roofing Contractors Association.

Proper unit installation requires that the roof curb be firmly and permanently attached to the roof structure. Check for adequate fastening method prior to setting the unit on the curb.

Full perimeter roof curbs are available from the factory and are shipped unassembled. The installing contractor is responsible for field assembly, squaring, leveling, and mounting on the roof structure. All required hardware necessary for the assembly of the sheet metal curb is included in the curb accessory package.

- Determine sufficient structural support before locating and mounting the curb and package unit.
- Duct-work must be constructed using industry guidelines. The duct-work must be placed into the roof curb before mounting the package unit. Our full perimeter curbs include duct connection frames to be assembled with the curb. Cantilevered-type curbs are not available from the factory.
- Contractor furnishes curb insulation, cant strips, flashing, and general roofing material.
- Support curbs on parallel sides with roof members. To prevent damage to the unit, the roof members cannot penetrate supply and return duct openings.

**Note:** The unit and curb accessories are designed to allow vertical duct installation before unit placement. Duct installation after unit placement is not recommended.

See the manual shipped with the roof curb for assembly and installation instructions.

3-D VIEW

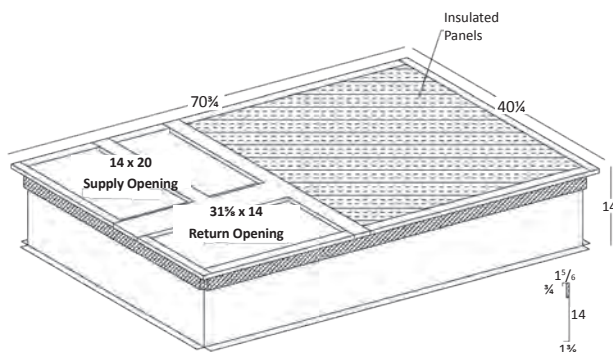

TOP VIEW

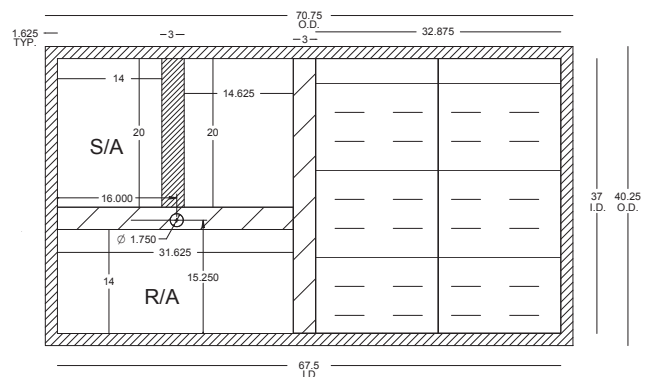

# WIRING DIAGRAM — CPH036-48\*\*\*1D\*\*\* (SINGLE-PHASE DIRECT DRIVE)

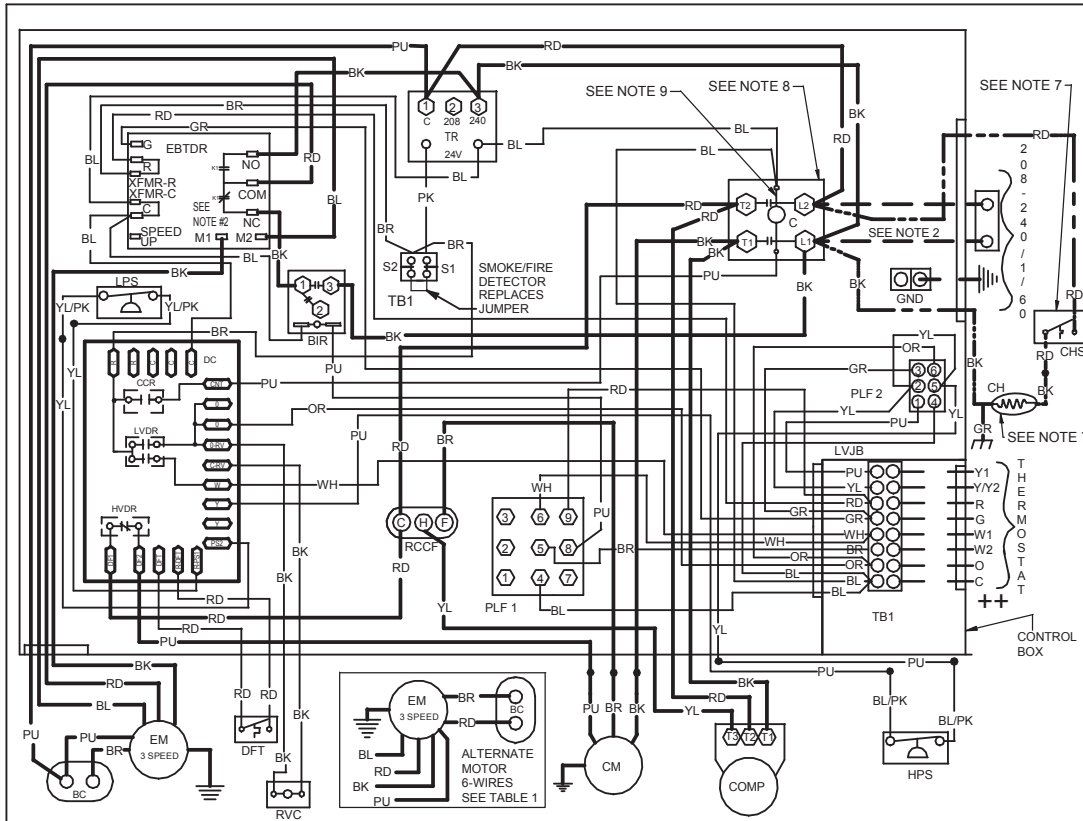

**High Voltage:** Disconnect all power before servicing or installing this unit. Multiple power sources may be present. Failure to do so may cause property damage, personal injury, or death.



Wiring is subject to change. Always refer to the wiring diagram or the unit for the most up-to-date wiring.

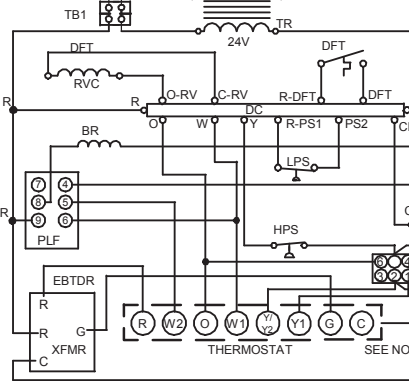
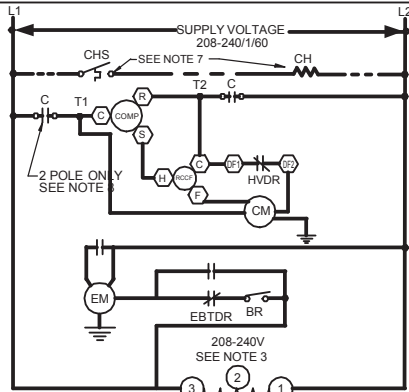

**COMPONENT LEGEND**

BIR	BLOWER INTERLOCK RELAY
C	CONTACTOR
CCR	COMPRESSOR CONTACTOR RELAY
CH	CRANKCASE HEATER
CHS	CRANKCASE HEATER SWITCH
CM	CONDENSER MOTOR
COMP	COMPRESSOR
DC	DEFROST CONTROL
DFT	DEFROST THERMOSTAT
ECON	ECONOMIZER
EM	EVAPORATOR MOTOR
GND	EQUIPMENT GROUND
HPS	HIGH PRESSURE SWITCH
HVDR	HIGH VOLTAGE DEFROST RELAY
LVD	LOW VOLTAGE DEFROST RELAY
LVJB	LOW VOLTAGE JUNCTION BOX
PLF	FEMALE PLUG / CONNECTOR
RVC	REVERSING VALVE COIL
RCCF	RUN CAPACITOR FOR CONDENSER FAN
TB1	TERMINAL BLOCK (24V SIGNAL)
TR	TRANSFORMER
BC	BLOWER CAPACITOR

- NOTES:**
- REPLACEMENT WIRE MUST BE SAME SIZE AND TYPE INSULATION AS ORIGINAL (AT LEAST 105°C) USE COPPER CONDUCTOR ONLY.
  - TO CHANGE EVAPORATOR MOTOR SPEED MOVE M1 OR M2 WIRE TO COM TERMINAL ON EBTDR AND PLACE WIRE REMOVED FROM COM ON EMPTY M1 OR M2 TERMINAL.
  - FOR 208 VOLT TRANSFORMER OPERATION MOVE BLACK WIRES FROM TERMINAL 3 TO TERMINAL 2 ON TRANSFORMER.
  - USE COPPER CONDUCTORS ONLY. ++ USE N.E.C. CLASS 2 WIRE
  - ECONOMIZER PLUG LOCATED IN RETURN AIR COMPARTMENT. REMOVE MALE PLUG AND ATTACH TO ECONOMIZER ACCESSORY.
  - DIAGRAM SHOWS FACTORY SPEED TAP SETTINGS.
  - CRANKCASE HEATER AND CRANKCASE HEATER SWITCH FACTORY EQUIPPED WHEN REQUIRED.
  - DOUBLE POLE CONTACTOR SHOWN. SINGLE POLE CONTACTOR COULD BE FACTORY EQUIPPED AS AN ALTERNATE CONFIGURATION.
  - COMMON SIDE OF CONTACTOR CAN NOT BE GROUNDED OR CONNECTED TO ANY OTHER COMMON (24V).

RD	COM (EBTDR)
BK	M1 (EBTDR)
BL	M2 (EBTDR)
PU	PIN 1 (24V XFMR)

RD	LOW
BL	MED
BK	HIGH

SEE UNIT RATING PLATE FOR TYPE AND SIZE OF OVER CURRENT PROTECTION  
208-240/1160 0140L01080-B

**FACTORY WIRING**

— LINE VOLTAGE  
— LOW VOLTAGE  
— OPTIONAL  
— HIGH VOLTAGE

**FIELD WIRING**

— HIGH VOLTAGE  
— LOW VOLTAGE

**WIRE CODE**

BK BLACK  
BL BLUE  
BR BROWN  
GR GREEN  
OR ORANGE  
PK PINK  
PU PURPLE  
RD RED  
WH WHITE  
YL YELLOW  
BL/PK BLUE WITH PINK STRIP  
YL/PK YELLOW WITH PINK STRIP

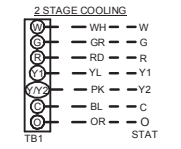
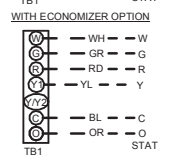
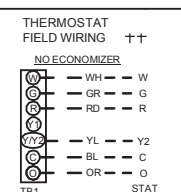

# WIRING DIAGRAM — CPH036-48\*\*\*3D\*\*\* (THREE-PHASE DIRECT DRIVE)

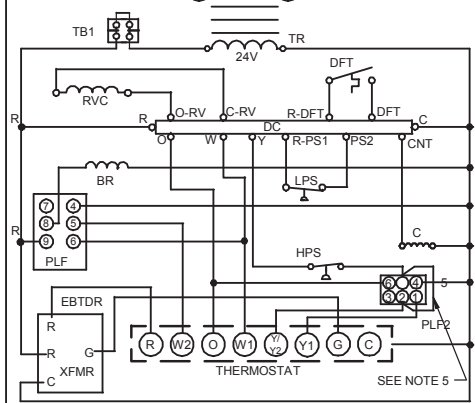
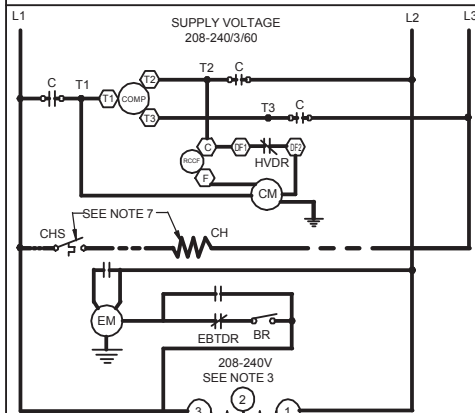
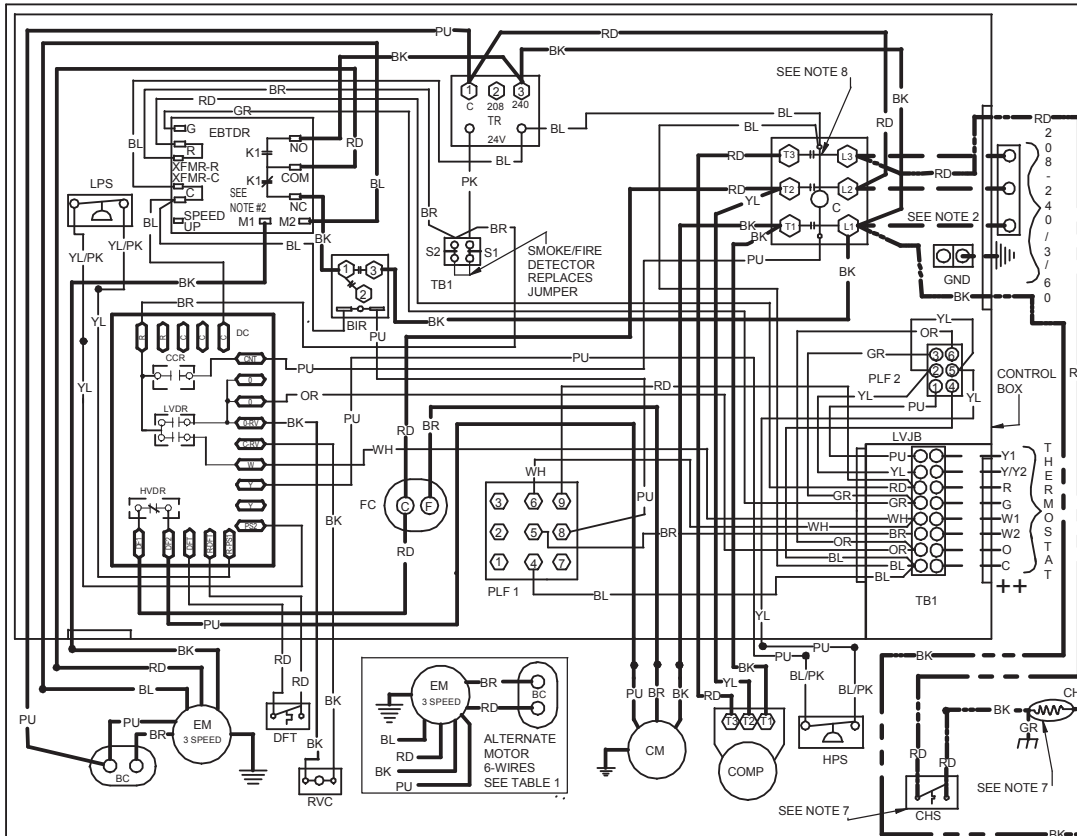

**COMPONENT LEGEND**

BIR	BLOWER INTERLOCK RELAY CONTACTOR
CCR	COMPRESSOR CONTACTOR RELAY
CH	CRANKCASE HEATER
CHS	CRANKCASE HEATER SWITCH
CM	CONDENSER MOTOR
COMP	COMPRESSOR
DC	DEFROST CONTROL
DFT	DEFROST THERMOSTAT
ECON	ECONOMIZER
EM	EVAPORATOR MOTOR
FC	FAN CAPACITOR
GND	EQUIPMENT GROUND
HPS	HIGH PRESSURE SWITCH
HVDR	HIGH VOLTAGE DEFROST RELAY
LPS	LOW PRESSURE SWITCH
LVDR	LOW VOLTAGE DEFROST RELAY
LVJB	LOW VOLTAGE JUNCTION BOX
PLF	FEMALE PLUG / CONNECTOR
RVC	REVERSING VALVE COIL
TB1	TERMINAL BLOCK (24V SIGNAL)
TR	TRANSFORMER
BC	BLOWER CAPACITOR

- NOTES:**
- REPLACEMENT WIRE MUST BE SAME SIZE AND TYPE INSULATION AS ORIGINAL (AT LEAST 105°C) USE COPPER CONDUCTOR ONLY.
  - TO CHANGE EVAPORATOR MOTOR SPEED MOVE M1 OR M2 WIRE TO COM TERMINAL ON EBTDR AND PLACE WIRE REMOVED FROM COM ON EMPTY M1 OR M2 TERMINAL.
  - FOR 208V TRANSFORMER OPERATION MOVE BK WIRES FROM TERMINAL 3 TO TERMINAL 2 ON TRANSFORMER.
  - USE COPPER CONDUCTORS ONLY
  - USE N.E.C. CLASS 2 WIRE
  - ECONOMIZER PLUG LOCATED IN THE RETURN AIR COMPARTMENT. REMOVE MALE PLUG AND ATTACH FEMALE PLUG TO ECONOMIZER ACCESSORY.
  - DIAGRAM SHOWS FACTORY SPEED TAP SETTINGS.
  - CRANKCASE HEATER AND CRANKCASE HEATER SWITCH FACTORY EQUIPPED WHEN REQUIRED.
  - COMMON SIDE OF CONTACTOR CAN NOT BE GROUNDED OR CONNECTED TO AN Y OTHER COMMON (24V).

<b>TABLE 1</b> ALTERNATE MOTOR WIRING COLOR TERMINATION	<b>TABLE 2</b> SPEED TAPS
RD COM (EBTDR)	BL LOW
BK M1 (EBTDR)	BL MED
BL M2 (EBTDR)	BK HIGH
PU PIN 1 (24V XFMR)	

SEE UNIT RATING PLATE FOR TYPE AND SIZE OF OVER CURRENT PROTECTION

**FACTORY WIRING**

—	LINE VOLTAGE
---	LOW VOLTAGE
---	OPTIONAL
---	HIGH VOLTAGE
---	FIELD WIRING
---	HIGH VOLTAGE
---	LOW VOLTAGE

**WIRE CODE**

BK	BLACK
BL	BLUE
BR	BROWN
GR	GREEN
OR	ORANGE
PK	PINK
PU	PURPLE
RD	RED
WH	WHITE
YL	YELLOW
BL/PK	BLUE WITH PINK STRIP
YL/PK	YELLOW WITH PINK STRIP

**THERMOSTAT FIELD WIRING**

NO ECONOMIZER

W1	WH	W
G	GR	G
R	RD	R
Y1	YL	Y
C	BL	C
O	OR	O
STAT		

WITH ECONOMIZER OPTION

W1	WH	W
G	GR	G
R	RD	R
Y1	YL	Y
C	BL	C
O	OR	O
STAT		

2 STAGE COOLING

W1	WH	W
G	GR	G
R	RD	R
Y1	YL	Y1
Y2	PK	Y2
C	BL	C
O	OR	O
STAT		

**High Voltage:** Disconnect all power before servicing or installing this unit. Multiple power sources may be present. Failure to do so may cause property damage, personal injury, or death.

**WARNING**

Wiring is subject to change. Always refer to the wiring diagram or the unit for the most up-to-date wiring.



# WIRING DIAGRAM — CPH36-72\*\*\*3B\*\*\* (THREE PHASE, BELT DRIVE)

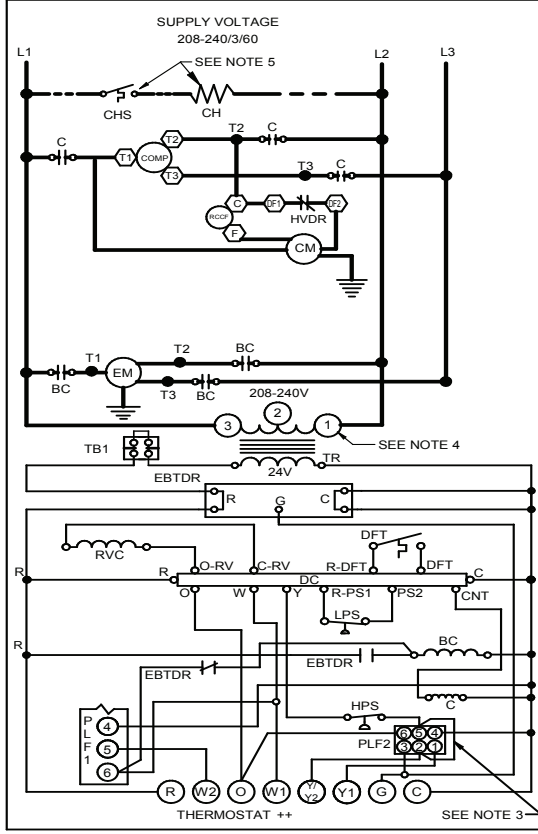
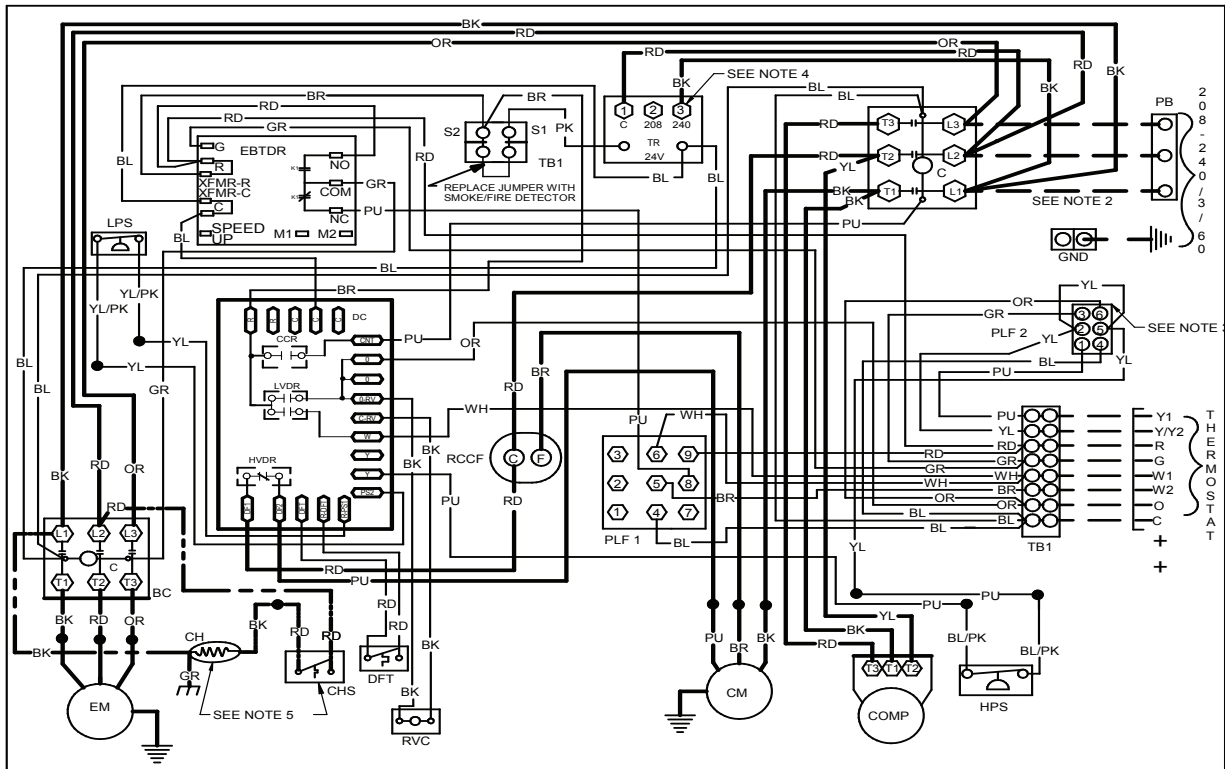

**COMPONENT LEGEND**

BC	BLOWER CONTACTOR
C	COMPRESSOR CONTACTOR RELAY
CCR	CONTACTOR
CH	CRANKCASE HEATER
CHS	CRANKCASE HEATER SWITCH
CM	CONDENSER MOTOR
COMP	COMPRESSOR
DC	DEFROST CONTROL
DFT	DEFROST THERMOSTAT
ECON	ECONOMIZER
EBTD	ELECTRONIC BLOWER TIME DELAY
EMR	EVAPORATOR MOTOR RELAY
EM	EVAPORATOR MOTOR
GND	EQUIPMENT GROUND
HPS	HIGH PRESSURE SWITCH
HVDR	HIGH VOLTAGE DEFROST RELAY
LVDR	LOW VOLTAGE DEFROST RELAY
LPS	LOW PRESSURE SWITCH
PLF	FEMALE PLUG / CONNECTOR
RVC	REVERSING VALVE COIL
RCCF	RUN CAPACITOR FOR CONDENSER FAN
TB1	TERMINAL BLOCK (24V SIGNAL) TRANSFORMER
TR	TRANSFORMER

**NOTES:**

- REPLACEMENT WIRE MUST BE SAME SIZE AND TYPE INSULATION AS ORIGINAL (AT LEAST 105°C) USE COPPER CONDUCTOR ONLY.
- USE COPPER CONDUCTORS ONLY \*\* USE N.E.C. CLASS 2 WIRE.
- ECONOMIZER PLUG LOCATED IN THE RETURN AIR COMPARTMENT. REMOVE MALE PLUG AND ATTACH FEMALE PLUG TO THE ECONOMIZER ACCESSORY.
- FOR 208 VOLT TRANSFORMER OPERATION MOVE BLACK WIRE FROM TERMINAL 3 TO TERMINAL 2 ON TRANSFORMER.
- CRANKCASE HEATER AND CRANKCASE HEATER SWITCH FACTORY EQUIPPED WHEN REQUIRED.

SEE UNIT RATING PLATE FOR TYPE AND SIZE OF OVER CURRENT PROTECTION

208-240/3/60 0140L01057-B

**FACTORY WIRING**

— LINE VOLTAGE  
 - - - LOW VOLTAGE  
 - - - - OPTIONAL HIGH VOLTAGE

**FIELD WIRING**

— HIGH VOLTAGE  
 - - - LOW VOLTAGE

**WIRE CODE**

BK BLACK  
 BL BLUE  
 BR BROWN  
 GR GREEN  
 OR ORANGE  
 PK PINK  
 PU PURPLE  
 RD RED  
 WH WHITE  
 YL YELLOW  
 BL/PK BLUE WITH PINK STRIP  
 YL/PK YELLOW WITH PINK STRIP

**THERMOSTAT FIELD WIRING**

**NO ECONOMIZER**

1	WH	W
2	GR	G
3	RD	R
4	YL	Y
5	BL	C
6	OR	O

TB1 STAT

**WITH ECONOMIZER OPTION**

1	WH	W
2	GR	G
3	RD	R
4	YL	Y
5	BL	C
6	OR	O

TB1 STAT

**2-STAGE COOLING**

1	WH	W
2	GR	G
3	RD	R
4	YL	Y1
5	PK	Y2
6	BL	C
7	OR	O

TB1 STAT

Wiring is subject to change. Always refer to the wiring diagram or the unit for the most up-to-date wiring.

**WARNING**

High Voltage: Disconnect all power before servicing or installing this unit. Multiple power sources may be present. Failure to do so may cause property damage, personal injury, or death.



WIRING DIAGRAM — CPH036-72\*\*\*4B/7B\*\*\* (460V/ 575V, BELT DRIVE)

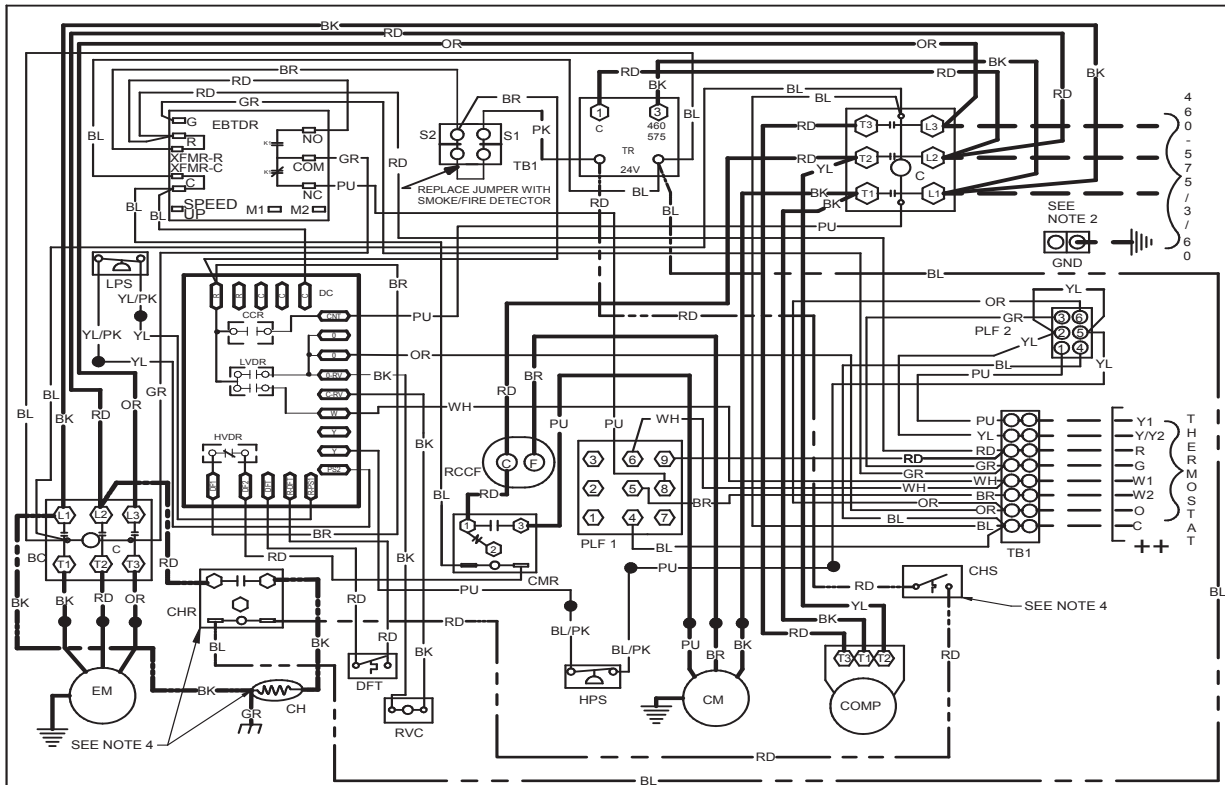

High Voltage: Disconnect all power before servicing or installing this unit. Multiple power sources may be present. Failure to do so may cause property damage, personal injury, or death.

**WARNING**

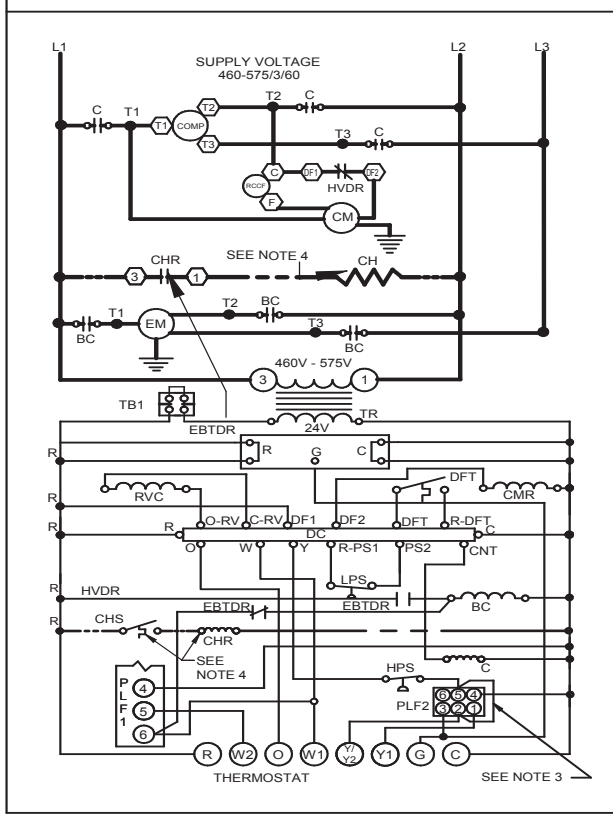

**COMPONENT LEGEND**

BC	BLOWER CONTACTOR
C	CONTACTOR
CCR	COMPRESSOR CONTACTOR RELAY
CH	CRANKCASE HEATER
CHS	CRANKCASE HEATER SWITCH
CHR	CRANKCASE HEATER RELAY
CM	CONDENSER MOTOR
CMR	CONDENSER MOTOR RELAY
COMP	COMPRESSOR
DC	DEFROST CONTROL
DFT	DEFROST THERMOSTAT
ECON	ECONOMIZER
EBTD	ELECTRONIC BLOWER TIME DELAY
EMR	EVAPORATOR MOTOR RELAY
EM	EVAPORATOR MOTOR
GND	EQUIPMENT GROUND
HPS	HIGH PRESSURE SWITCH
HVDR	HIGH VOLTAGE DEFROST RELAY
LVDR	LOW VOLTAGE DEFROST RELAY
LPS	LOW PRESSURE SWITCH
LVDR	LOW VOLTAGE DEFROST RELAY
PLF	FEMALE PLUG / CONNECTOR
RVC	REVERSING VALVE COIL
RCCF	RUN CAPACITOR FOR CONDENSER FAN
TB1	TERMINAL BLOCK (24V SIGNAL) TRANSFORMER
TR	TRANSFORMER

- NOTES:**
- REPLACEMENT WIRE MUST BE SAME SIZE AND TYPE INSULATION AS ORIGINAL (AT LEAST 105°C) USE COPPER CONDUCTOR ONLY.
  - USE COPPER CONDUCTORS ONLY  
++ USE N.E.C. CLASS 2 WIRE
  - ECONOMIZER PLUG LOCATED IN THE RETURN AIR COMPARTMENT. REMOVE MALE PLUG AND ATTACH FEMALE PLUG TO THE ECONOMIZER ACCESSORY.
  - CRANKCASE HEATER, CRANKCASE HEATER RELAY, AND CRANKCASE HEATER SWITCH FACTORY EQUIPPED WHEN REQUIRED.

SEE UNIT RATING PLATE FOR TYPE AND SIZE OF OVER CURRENT PROTECTION

**FACTORY WIRING**

LINE VOLTAGE  
LOW VOLTAGE  
OPTIONAL  
HIGH VOLTAGE  
OPTIONAL  
LOW VOLTAGE  
FIELD WIRING  
HIGH VOLTAGE  
LOW VOLTAGE

**WIRE CODE**

BK BLACK  
BL BLUE  
BR BROWN  
GR GREEN  
OR ORANGE  
PK PINK  
PU PURPLE  
RD RED  
WH WHITE  
YL YELLOW  
BL/PK BLUE WITH PINK STRIP  
YL/PK YELLOW WITH PINK STRIP

**THERMOSTAT FIELD WIRING ++**

**NO ECONOMIZER**

WH	W
GR	G
RD	R
YL	Y
BL	C
OR	O

TB1 STAT

**WITH ECONOMIZER OPTION**

WH	W
GR	G
RD	R
YL	Y
BL	C
OR	O

TB1 STAT

**2 STAGE COOLING**

WH	W
GR	G
RD	R
YL	Y1
PK	Y2
BL	C
OR	O

TB1 STAT

# WIRING DIAGRAM — CPH060\*\*\*1D\*\*\* (SINGLE-PHASE, DIRECT DRIVE)

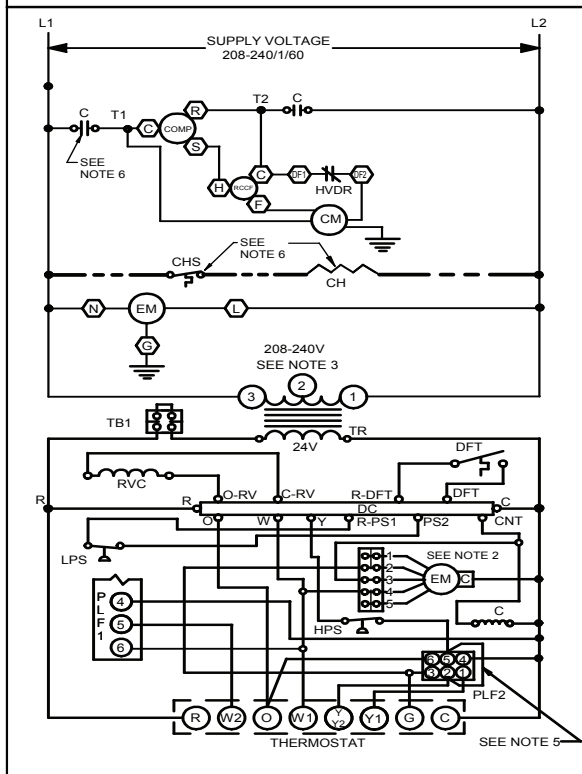
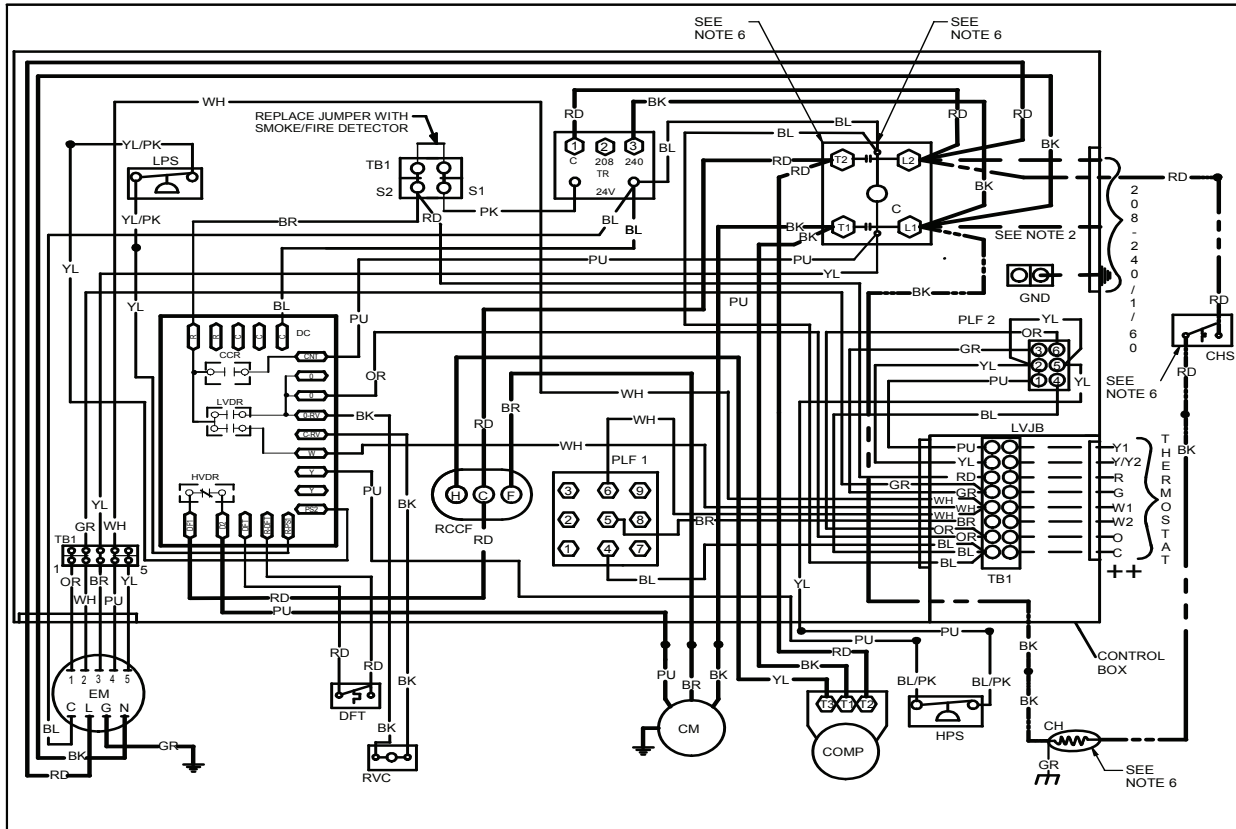

**COMPONENT LEGEND**

C	CONTACTOR
CCR	COMPRESSOR CONTACTOR RELAY
CH	CRANKCASE HEATER
CHS	CRANKCASE HEATER SWITCH
CM	COMPRESSOR MOTOR
COMP	COMPRESSOR
DC	DEFROST CONTROL
DFT	DEFROST THERMOSTAT
ECON	ECONOMIZER
EM	EVAPORATOR MOTOR
GND	EQUIPMENT GROUND
HPS	HIGH PRESSURE SWITCH
HVDR	HIGH VOLTAGE DEFROST RELAY
LPS	LOW PRESSURE SWITCH
LVDR	LOW VOLTAGE DEFROST RELAY
LVJB	LOW VOLTAGE JUNCTION BOX
PLF	FEMALE PLUG / CONNECTOR
RVC	REVERSING VALVE COIL
RCCF	RUN CAPACITOR FOR COMPRESSOR AND FAN
TB1	TERMINAL BLOCK (24V SIGNAL)
TR	TRANSFORMER

**NOTES:**

- REPLACEMENT WIRE MUST BE SAME SIZE AND TYPE INSULATION AS ORIGINAL (AT LEAST 105°C) USE COPPER CONDUCTOR ONLY.
- TO CHANGE EVAPORATOR MOTOR SPEED MOVE WHITE AND YELLOW LEADS FROM "3" AND "4" TO "4" AND "5". IF BOTH LEADS ARE ENERGIZED, THE HIGHER SPEED SETTING IS USED.
- FOR 208 VOLT TRANSFORMER OPERATION MOVE BLACK WIRE FROM TERMINAL 3 TO TERMINAL 2 ON TRANSFORMER.
- USE COPPER CONDUCTORS ONLY  
++ USE N.E.C. CLASS 2 WIRE
- ECONOMIZER PLUG LOCATED IN THE RETURN AIR COMPARTMENT. REMOVE MALE PLUG AND ATTACH FEMALE PLUG TO ECONOMIZER ACCESSORY.
- CRANKCASE HEATER AND CRANKCASE HEATER SWITCH FACTORY EQUIPPED WHEN REQUIRED.
- DOUBLE POLE CONTACTOR SHOWN. SINGLE POLE CONTACTOR COULD BE FACTORY EQUIPPED AS AN ALTERNATE CONFIGURATION.
- COMMON SIDE OF CONTACTOR CAN NOT BE GROUNDED OR CONNECTED TO ANY OTHER COMMON (24V).

SEE UNIT RATING PLATE FOR TYPE AND SIZE OF OVER CURRENT PROTECTION

208-240/1/60 014L01056-B

**FACTORY WIRING**

LINE VOLTAGE  
LOW VOLTAGE  
OPTIONAL  
HIGH VOLTAGE

**FIELD WIRING**

HIGH VOLTAGE  
LOW VOLTAGE

**WIRE CODE**

BK BLACK  
BL BLUE  
BR BROWN  
GR GREEN  
OR ORANGE  
PK PINK  
RD RED  
PU PURPLE  
YL YELLOW  
WH WHITE  
BL/PK BLUE WITH PINK STRIP  
YL/PK YELLOW WITH PINK STRIP

**THERMOSTAT WIRING ++**

**NO ECONOMIZER**

1	WH	W
2	GR	G
3	RD	R
4	YL	Y
5	BL	C
6	OR	O

TB1      STAT

**WITH ECONOMIZER OPTION**

1	WH	W
2	GR	G
3	RD	R
4	YL	Y
5	BL	C
6	OR	O

TB1      STAT

**2 STAGE COOLING**

1	WH	W
2	GR	G
3	RD	R
4	YL	Y1
5	PK	Y2
6	BL	C
7	OR	O

TB1      STAT

Wiring is subject to change. Always refer to the wiring diagram or the unit for the most up-to-date wiring.



High Voltage: Disconnect all power before servicing or installing this unit. Multiple power sources may be present. Failure to do so may cause property damage, personal injury, or death.

# WIRING DIAGRAM — CPH060\*\*\*3D\*\*\* (THREE-PHASE, DIRECT DRIVE)

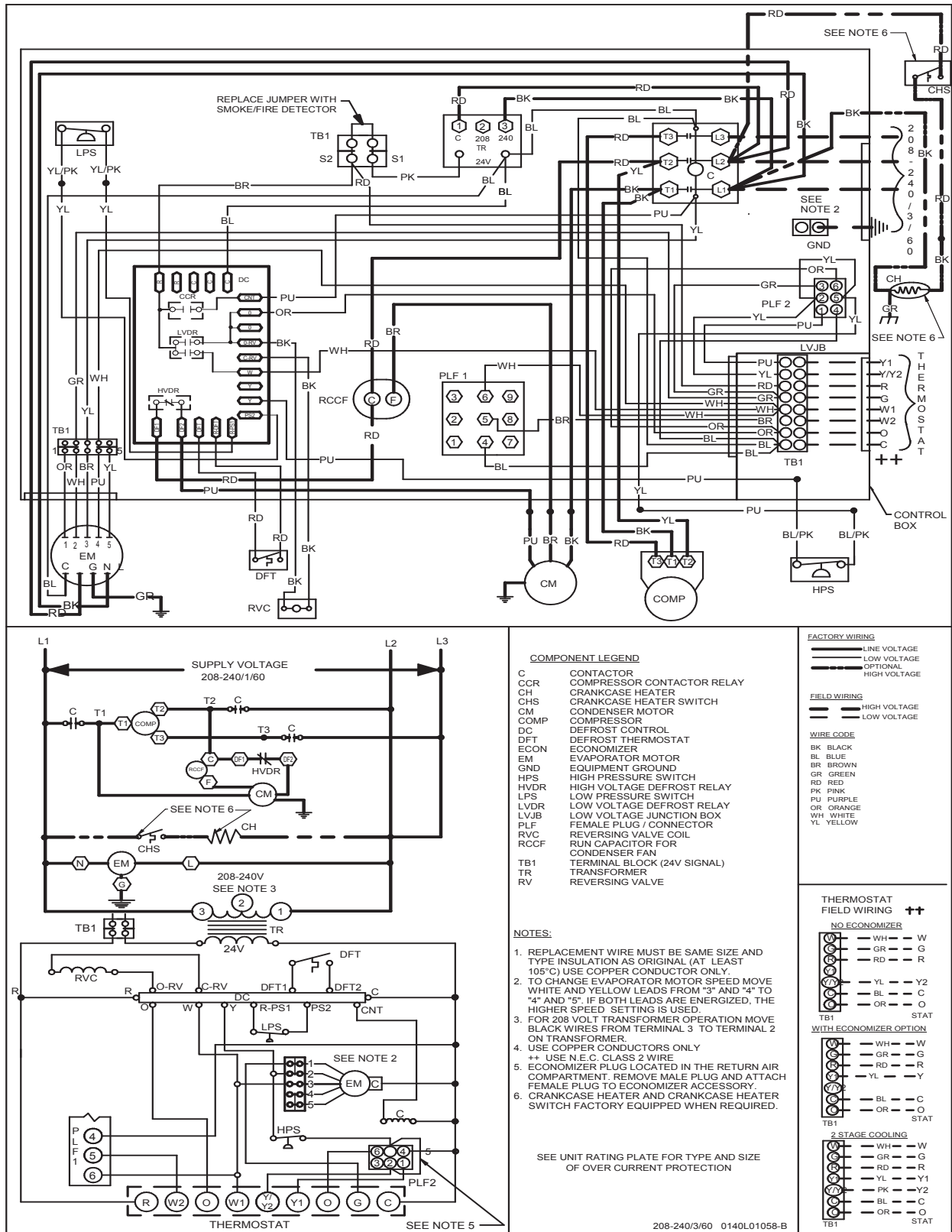

Wiring is subject to change. Always refer to the wiring diagram or the unit for the most up-to-date wiring.



**High Voltage:** Disconnect all power before servicing or installing this unit. Multiple power sources may be present. Failure to do so may cause property damage, personal injury, or death.

ACCESSORIES

FIELD ACCESSORY ITEM #	DESCRIPTION	FITS MODEL SIZES	FIELD- INSTALLED	FACTORY- INSTALLED
14CURB3672B	14" Roof Curb	3-6 tons	√	
25FD3672	25% Manual Fresh Air Damper	3-6 tons	√	
25MFD3672	25% Motorized Fresh Air Damper	3-6 tons	√	
DNBBS3672B	Burglar Bar Sleeves Includes Supply & Return	3-6 tons	√	
CDK36	Concentric Duct Kit	3 tons	√	
CDK4872	Concentric Duct Kit	4-6 tons	√	
HAILGD03	Condenser Coil Hail Guard	3-5 tons	√	√
HAILGD04	Condenser Coil Hail Guard	6 tons	√	√
	Convenience Outlet: Non Powered	All Models		√
	Convenience Outlet: Powered	All Models		√
	Disconnect Switch (non-fused)	All Models		√
DNECONHP3672B	Downflow Economizer	3-6 tons	√	√
DNSQRRND36B	Downflow Square-to-Round Adapter 16" Round	3 tons	√	
DNSQRRND4872B	Downflow Square-to-Round Adapter 18" Round	4-6 tons	√	
	Electric Heat Kits	All Models	√	√
HSKT036B	High-Static Kit (230/460v)	3 tons	√	√
HSKT048B	High-Static Kit (230/460v)	4 tons	√	√
HSKT060B	High-Static Kit (230/460v)	5 tons	√	√
HSKT072B	High-Static Kit (230/460v)	6 tons	√	√
BRD3672	Horizontal Barometric Relief Damper	3-6 tons	√	
HZECONHP3672B	Horizontal Economizer	3-6 tons	√	
GHRC-1	Hurricane Restraint Clip	All Models	√	
LAKT01	Low-Ambient Kit	3-6 tons	√	√
PE36722B	Power Exhaust 208/230 Volt	3-6 tons	√	
PE36724B	Power Exhaust 460 Volt	3-6 tons	√	
	Smoke Detector	All Models		√
	Stainless-Steel Heat Exchanger (Type 409)	All Models		√
	UltraGold Condenser Coil	All Models		√



Goodman Manufacturing Company, L.P., reserves the right to discontinue, or change at any time, specifications or designs without notice or without incurring obligations. © 2012 • Goodman Manufacturing Company, L.P. • Houston, Texas • Printed in the USA.