

Model

WETS 2020.1402-1.28-SMO

OPTIMA Plus® Battery Powered HET Flushometer and ADA Compliant HET Water Closet

DESCRIPTION

Complete HET system with exposed, battery powered, sensor activated, Royal® OPTIMA Plus® SMO Flushometer and ADA compliant vitreous china fixture.

Flush Cycle

Model WETS 2020.1402-1.28-SMO (1.28 gpf/4.8 Lpf)



Meets the American Disabilities Guidelines and ANSI A117.1 requirements when installed according to these requirements.



NOTE:

Plumbing System Requirements

- Minimum **Flowing** Pressure: 25 PSI
- Minimum Flow Rate: 18 GPM

SPECIFICATIONS

Quiet, exposed, diaphragm type, chrome plated HET Flushometer for either left or right hand supply and ADA compliant HET vitreous china fixture with the following features:

Flushometer and OPTIMA® SMO Unit

- PERMEX® Plus Synthetic Rubber Diaphragm with Dual Filter Bypass
- ADA Compliant OPTIMA® Battery Powered Infrared Sensor for automatic “No Hands” operation
- Chrome plated Infrared Sensor Housing
- Four (4) Size C batteries included
- “Low Battery” flashing LED
- “User in View” flashing LED
- Infrared Sensor Range Adjustment Screw and Reset Button
- 1" I.P.S. Screwdriver Bak-Chek® Angle Stop
- Free spinning, Vandal Resistant Stop Cap
- Adjustable Tailpiece
- High Back Pressure Vacuum Breaker Flush Connection with One-piece Bottom Hex Coupling Nut
- Spud Coupling and Flange for 1 1/2" Top Spud
- Sweat Solder Adapter w/Cover Tube and Cast Wall Flange w/Set Screw
- High copper, low zinc brass castings for dezincification resistance
- No external volume adjustment to ensure water conservation
- Stop Seat and Vacuum Breaker to be molded from PERMEX® rubber compound for chloramine resistance
- Valve Body, Cover, Tailpiece and Control Stop shall be in conformance with ASTM Alloy Classification for Semi-Red Brass. Valve shall be in compliance to the applicable sections of ASSE 1037.

Fixture

- ADA compliant floor mounted vitreous china
- 1 1/2" I.P.S. top spud inlet
- 2 1/8" trapway diameter
- Integral flushing rim
- Elongated bowl with siphon jet flush
- Closet bolts and caps included
- 100 % factory flush tested
- Toilet seat not included
- Compatible with toilet seat models: Olsonite 10CT, Bemis 1955CT & Church Commercial 295CT
- Water closet shall be in compliance to the applicable sections of ASME A112.19.2/CSA B45.1

FEATURES

Automatic

Sloan OPTIMA Plus® SMO equipped Flushometers provide the ultimate in sanitary protection and automatic operation. There is no need for AC hookups or wall alterations. The Flushometer operates by means of a battery powered infrared sensor. Once the user enters the sensor's effective range and then steps away, the Side Mount Operator initiates the flushing cycle to flush the fixture.

Hygienic

User makes no physical contact with the Flushometer surface. Helps control the spread of infectious diseases. 24-hour Sentinel Flush keeps fixture fresh during periods of nonuse.

Economical

Automatic operation and a very low flush volume provides water savings over other flushing devices. Reduces maintenance and operation costs. Installation and battery replacement does not require turning off water to the valve.

Warranty

3 year (limited)



Sloan Valve Company is buying renewable energy certificates to meet 100% of the company's purchased electricity use at its Franklin Park, Illinois facility.

SLOAN

Sloan Valve Company
10500 Seymour Avenue
Franklin Park, IL 60131
Phone: 1-800-9-VALVE-9 (982-5839)
or 1-847-671-4300
Fax: 1-800-447-8329 or 1-847-671-4380
www.sloanvalve.com

Copyright © 2010 Sloan Valve Company
Rev. 0b (10/10)

| | |
|---|----------------|
| This space for Architect/Engineer approval | |
| Job Name _____ | Date _____ |
| Model Specified _____ | Quantity _____ |
| Variations Specified _____ | |
| Customer/Wholesaler _____ | |
| Contractor _____ | |
| Architect _____ | |

DESCRIPTION

Complete HET system with exposed, battery powered, sensor activated, Royal® OPTIMA Plus® SMO Flushometer and ADA compliant vitreous china fixture.

Flush Cycle

Model WETS 2020.1402-1.28-SMO (1.28 gpf/4.8 Lpf)

ELECTRICAL SPECIFICATIONS

- **Control Circuit**
Solid state, 6 VDC input
- **OPTIMA Plus® Sensor Type**
Infrared convergence type object lock detection
- **OPTIMA Plus® Sensor Range**
Nominal 8" – 54" (203 mm – 1372 mm), factory set at 24" (610 mm)
- **Battery Type**
(4) Size C Alkaline
- **Battery Life**
2 Years @ 3,000 flushes/month
- **Indicator Lights**
User in view/low battery
- **Operating Pressure**
15 – 100 psi (104 – 689 kPa)

OPERATION

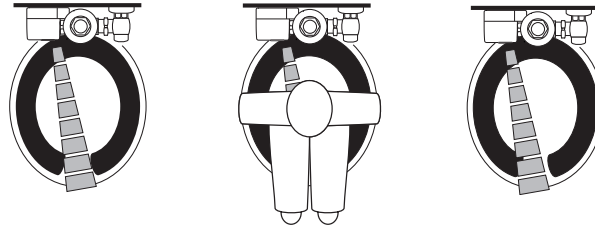

1. A continuous, invisible light beam is emitted from the Object Lock Infrared Sensor.
2. As the user enters the beam's effective range, 8" to 54" (203 mm – 1372 mm), the Object Lock Infrared Sensor senses the user.
3. When the user steps away from the Object Lock Infrared Sensor, the circuit initiates the flushing cycle to flush the fixture. The circuit then automatically resets and is ready for the next user.

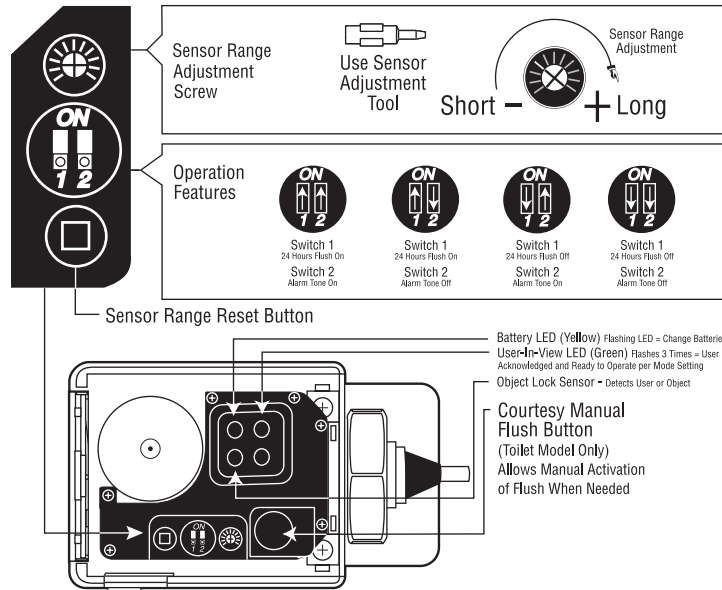

DIMENSIONS/ROUGH-IN

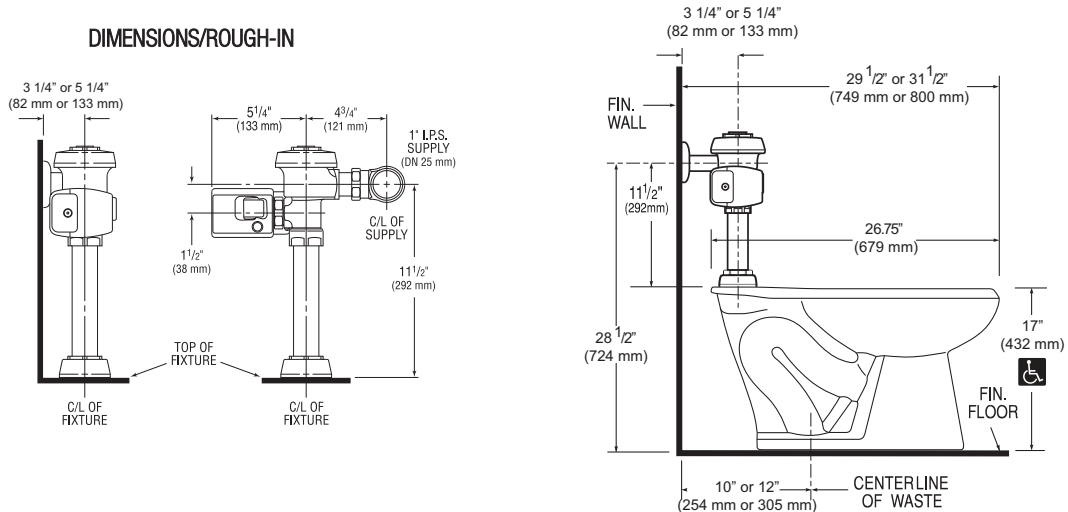

SLOAN VALVE COMPANY • 10500 SEYMOUR AVENUE • FRANKLIN PARK, IL 60131

Phone: 1-800-9-VALVE-9 or 1-847-671-4300 • Fax: 1-800-447-8329 or 1-847-671-4380 • www.sloanvalve.com