

Frame

Capacity: 2½" through 8" — 258
8" through 12" — 258XL

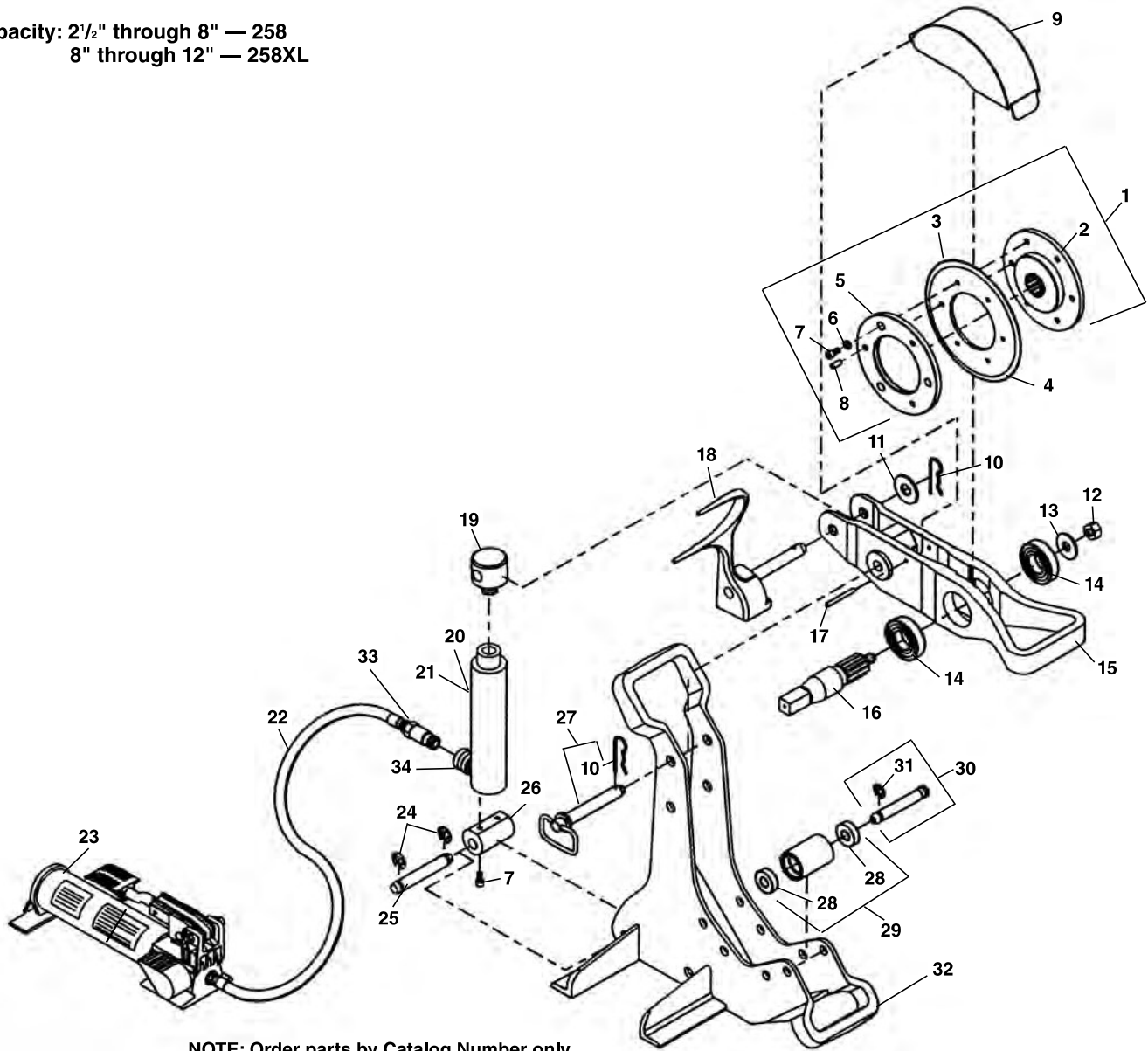

**NOTE: Order parts by Catalog Number only.
DO NOT order by Reference Number.**

Ref. No.	Catalog No.	Description	Ref. No.	Catalog No.	Description
—	50767	258 Pipe Cutter	18	50882	Reaction Arm (258)
—	58227	258XL Pipe Cutter		58887	Reaction Arm (258XL)
1	66687	Cutter Wheel Assy. Std. Includes Ref. Nos. 2,3,5,6,7,8	19	50877	Top Clevis
2	50782	Hub w/Pins	20	59517	10 Ton Hyd. Cylinder
3	50812	Cutter Wheel Std.	21	62557	Repair Kit f/Cylinder
4	58222	Cutter Wheel – Thin	22	59507	Hydraulic Hose
5	50792	Cover Plate	23	59512	HF-32 Foot Pump Incl. Ref. No. 22
6	40770	Lock Washer 5/16" (5)	24	58850	E-Clip (2)
7	50997	Screw 5/16" x 3/4" (5)	25	54327	Bottom Clevis Pin
8	50787	Pins (3)	26	50867	Bottom Clevis
9	50777	Guard	27	50847	Hitch Pin w/Hairpin (258 Only)
10	50852	Hairpin Cotter (2)	28	44565	Ball Bearing (8)
11	60995	Flat Washer 3/4" (258XL Only)	29	50837	Roller
12	50797	Locking Nut	30	54887	Roller Pin (4)
13	41220	Flat Washer 5/8"	31	42580	E-Clips (8)
14	50802	Ball Bearing (2)	32	50842	Frame (258)
15	50807	Pivot Arm		58882	Frame (258XL)
16	50827	Drive Shaft	33	62552	Hose Half Coupler
17	27052	Roll Pin 1/4" x 2 3/8"	34	62547	Ram Half Coupler

Hydraulic Foot Pump, HF 32

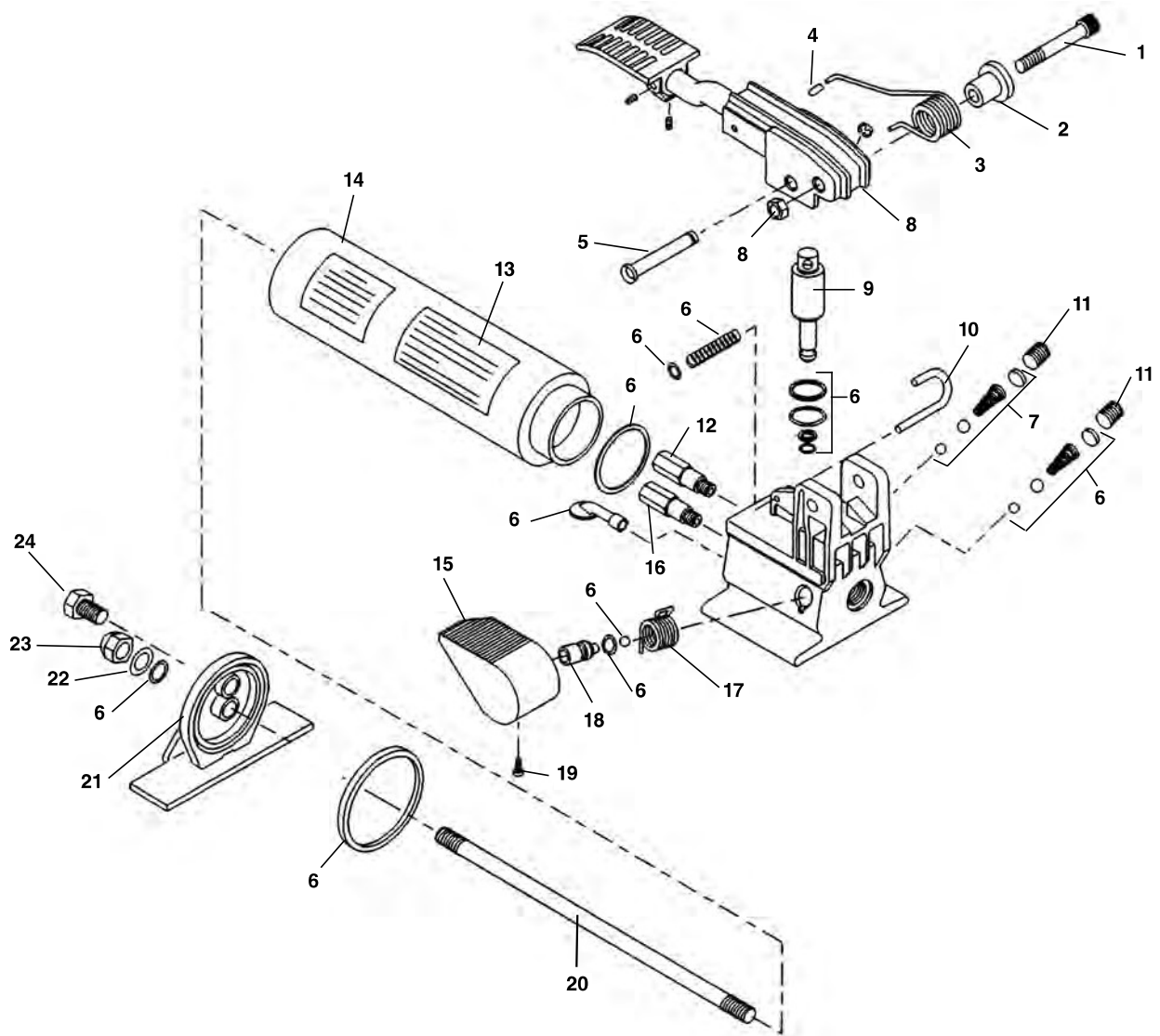

**NOTE: Order parts by Catalog Number only.
DO NOT order by Reference Number.**

Ref. No.	Catalog No.	Description	Ref. No.	Catalog No.	Description
—	59512	HF32 Foot Pump	13	62572	Decal, HF32 Instruction
1	63767	Socket Head Capscrew	14	63687	Reservoir
2	63777	Spacer	15	63727	Release Foot Pedal
3	63772	Torsion Spring	16	63757	Relief Valve Assembly
4	63787	Cap	17	63722	Release Spring
5	63762	Cross Pin w/Ret. Ring	18	63737	Valve Spindle
6	63657	HF32 Repair Kit	19	63732	Screw
7	63782	Hex Nut	20	63692	Tie Rod
8	63812	Foot Pedal	21	63702	Reservoir Support
9	63817	Plunger Assembly	22	63717	Pkg. of 2 Washers
10	63747	Locking Pin	23	63707	Acorn Nut
11	63742	Pipe Plug	24	63712	Plug
12	63752	By-Pass Valve			