



HYMAX[®] COUPLING[❖]

(1.5" - 60")

HYMAX[®]
Repair the past. Connect the future.

PRODUCT SPECIFICATIONS

FEATURES

- GAME-CHANGING WIDE-RANGE COUPLING, PROVEN IN OVER 1M INSTALLATIONS IN THE US
- SUITABLE FOR ALL TYPES OF PIPES - DUCTILE IRON, CAST IRON, STEEL, COPPER, PE, PVC, AC, GRP
- PATENTED HYDRAULICALLY-ASSISTED GASKET WITH 2-STAGE SEALING
- LIGHTWEIGHT CONSTRUCTION ENABLES FAST AND EASY INSTALLATION
- ALLOWS 4° DYNAMIC DEFLECTION ON EACH END, REDUCING FUTURE PIPE DAMAGE
- ONE PRODUCT CAN CONNECT PIPES OF TWO DIFFERENT MATERIALS

SPECIFICATIONS

STANDARDS

HYMAX MEETS OR EXCEEDS STANDARDS AWWA C-219, NSF 61, NSF 372.

SIZE

AVAILABLE IN NOMINAL DIAMETER FROM 1.5" - 60".
CALL KRAUSZ FOR DETAILS.

MATERIALS

END RINGS

1.5" - 12" ASTM A283 / A283M GRADE C STEEL.
14" - 16" ASTM A283 / A283M GRADE C STEEL.
(OR DUCTILE IRON CASTING ASTM A536 GRADE 60-40-18).
18" - 60" ASTM A283 / A283M GRADE C STEEL.

CENTER RING

1.5" - 12" ASTM A53 GRADE A STEEL.
14" - 60" ASTM A283 / A 283M GRADE C STEEL.

GASKETS

EPDM AND NBR AVAILABLE. BOTH ARE COMPOUNDED FOR WATER AND SEWAGE,
MEET INTERNATIONAL STANDARDS FOR CONTACT WITH DRINKING WATER.

BRIDGE

AISI 304 STAINLESS STEEL.

SPHERICAL SPACERS

AISI 304 STAINLESS STEEL.

COATING

100% FUSION BONDED EPOXY FOR ENHANCED CORROSION PROTECTION.
NOMINAL THICKNESS 14 MIL.

NUTS AND BOLTS

AISI 304 STAINLESS STEEL. ROLLED THREAD AND ANTI-GALLING COATING.

* REGISTERED PATENT

PRODUCT PERFORMANCE (*)

WORKING TEMPERATURE	EPDM: -20°F UP TO +125°F NBR: -4°F UP TO +125°F			
DYNAMIC DEFLECTION	UP TO 4° PER SIDE.			
MIN. PIPE INSERTION	1.5"-12" 2.25"	14"- 60" 4"		
MAXIMUM OFFSET FOR MISALIGNED PIPES	1.5"- 3" 0.39"	4"- 60" 0.51"		
MAXIMUM OUT OF ROUNDNESS	1.5" 0.08"	2"- 3" 0.20"	4"- 12" 0.31"	14"- 60" 0.51"
WORKING PRESSURE	1.5"- 16" 260 PSI	18"- 24" 232 PSI	26"- 60" CALL KRAUSZ FOR DETAILS.	
RATED PRESSURE	1.5"- 16" 390 PSI	18"- 24" 350 PSI	26"- 60" CALL KRAUSZ FOR DETAILS.	
VACUUM TEST	12 PSI			

* SEE SUBMITTAL DRAWINGS FOR DETAILS.

PRODUCT TABLES

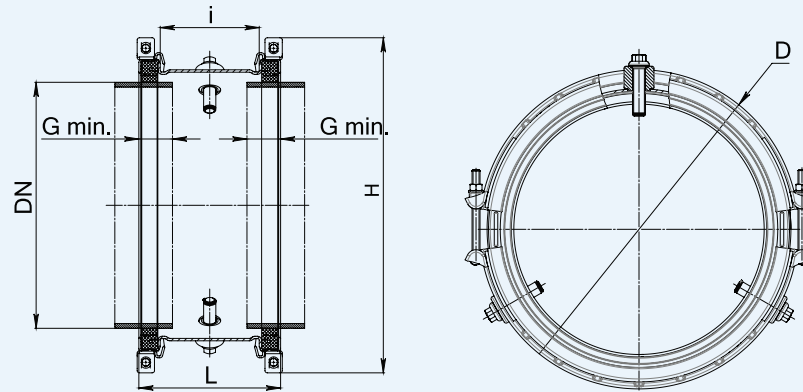

HYMAX NOMINAL SIZES 14"-24"

Krausz Part Number	ND (inch)	Overall Range (inch)	Before Removal of Inner Layer (inch)	After Removal of Inner Layer (inch)	D (inch)	H (inch)	i (inch)	L (inch)	G-Min Pipe Insert (inch)	Bolts Qty. and Size (mm)	Torque (Ft-Lb)	Working Pressure (PSI)	Rated Pressure (PSI)	Approx. Weight (Lbs)
860-56-0378-16P	14	15.00-17.10	15.00-16.10	16.02-17.10	Ø21.0	23.2	8.0	11.6	4.0	4 -M16	150	260	390	92
860-56-0434-16P	16	17.10-19.20	17.10-18.19	18.11-19.20	Ø23.2	25.6	8.0	11.6	4.0	4 -M16	150	260	390	101
860-56-0488-16P	18	19.20-21.30	19.20-20.29	20.21-21.30	Ø25.3	27.8	8.0	11.6	4.0	4 -M16	150	232	350	101
860-56-0497-16P	20	19.60-21.70	19.60-20.69	20.61-21.70	Ø25.6	28.1	8.0	11.6	4.0	4 -M16	150	232	350	105
860-56-0540-16P	20	21.25-23.35	21.25-22.35	22.27-23.35	Ø27.3	29.8	8.0	11.6	4.0	4 -M16	150	232	350	110
860-56-0606-16P	24	23.85-25.95	23.85-24.96	24.88-25.95	Ø29.1	31.7	8.0	11.6	4.0	4 -M16	150	232	350	120
860-56-0624-16P	24	24.60-26.70	24.60-25.67	25.59-26.70	Ø30.6	33.2	8.0	11.6	4.0	4 -M16	150	232	350	120

HYMAX 26"-60" - MTO (MADE TO ORDER) AVAILABLE
 FOR SPECIFIC SIZES OF PRODUCTS IN STOCK, CALL KRAUSZ FOR DETAILS.