



# Product Catalog

## Commitment

Fernco is committed to giving the highest level of quality, Fernco quality, at the most competitive price. Our goal is to maintain standards of excellence in quality and service, while continuing to be the most innovative company in the industry.

## Convenient Ordering, Fast Delivery

Fernco's phone ordering system ensures easy ordering and prompt delivery for our customers. When you call Fernco, you will be assisted by a trained professional who knows the industry and understands your individual needs. Your order will be quickly entered into our data processing system for accurate recording of specifications and costs.

Only Fernco offers you the industry's largest product line, highest fill rate and the most complete merchandising program. All of which is supported by over fifty years of design, manufacturing and distribution experience combined with an ongoing commitment to product innovation.

### United States

(810) 503-9000

fernco.com

### Canada

(519) 332-6711

fernco.ca

# INDEX

## FLEXIBLE COUPLINGS

Standard	4-5
Proflex	6-7
1000 StrongBack RC	8
5000 StrongBack RC	9
XL Couplings	10
Flexible Chemical Couplings	11
Puddle Flange	12
No Hub	13
Plastic Socket	13
Pipe Sleeves	13
Expansion Joints	14
Qwik Tee & Ell	14
Western Stop & Bushing	14
Corrugated	15
High Torque Corrugated	15
Ultra Rib	16
Eccentric	16
Large Diameter	16
Stainless Steel Clamps	17
Torque Wrenches	17
Large Diameter Caps	17
Qwik Caps	18

## LATERAL CONNECTIONS

QwikSeal	19
Tap Saddles & Pressure Kit	21

## INTERNAL SEALS

ICON Pushfit	22
Donuts	23
O-Rings	23
Concrete Manhole Adapters	24
Multi-Tite Gaskets	24
Wax Free Toilet Seal	25
Wax Free Urinal Seal	25

## WATER MANAGEMENT

StormDrain Plus	26
Water Well Debris Traps	27
Downspout Connectors	27
Sump Pump Check Valve	27

## SEALANTS

Pow-R Patch	28
Pow-R Wrap	28
Pow-R Industrial	28

## FLEXIBLE CONNECTORS

Hose Bibbs	29
Flexible Qwik Traps	29
Drain & Trap	29
Tubular Drain Pipe	30
Dishwasher	30
Shower Drain	30
Fix-A-Flange	31
Utility	31
Hose Grip Washer	31

## RESOURCES

### Coupling Sizing Charts

- Clay to Clay	32
- Clay to Cast Iron (CI), Plastic, Copper, Steel or Lead	33
- Clay to Asbestos Cement Fibre (AC) or Ductile Iron (DI)	34
- Concrete to Concrete	35
- Concrete to Clay	36
- Concrete to CI, Plastic, Copper, Steel or Lead	36
- AC or DI to CI, Plastic, Copper, Steel or Lead	37
- AC or DI to AC or DI	38
- CI Plastic, Copper, Steel or Lead to CI, Plastic, Steel or Lead	39
- Concrete to DI	40

Plumbing Market Reps	42
Waterworks Market Reps	44
Acid Resistance Chart	46

# A global company with a focus on the individual customer.

## Established in 1964

In the 1950's, William Zopfi was looking for a reliable solution to fit his pipe connection needs for sewer lines in the Detroit, MI area. He developed a tar donut that would allow him to create more connections per day, increasing his efficiency in the field. In 1964, the Fernco Joint Sealer Company was formally established when the 'd-nut' became patented. When word spread of this invention, Zopfi, set up a small shop behind his plumbing business to begin producing the Donut. Thus, setting Fernco on it's course for the future.

When Darrell Cooper joined the team, he had a philosophy of working closely with wholesale distributors to provide products in a timely manner. This would prove to be a core value that was as important then as it is today.

In 1973, Dallas, Texas, requested a bid for the first Fernco Coupling to fit a pipe without a bell housing. Cooper saw this product as an opportunity for vast growth and established couplings in the market. Fernco then moved to its current headquarters in Davison, Michigan, allowing the company to expand and expedite their manufacturing and shipping process. In 1978, Cooper was named President of the company and purchased Fernco Joint Sealer Company, forming a new company, Fernco, Inc.

## Industry Leaders

Fernco has continued to grow into different markets, while developing innovative and reliable products. Fernco has expanded throughout North and South America and acquired Flexseal Couplings LTD, the leading manufacturer of flexible couplings in the European market. The Flexseal acquisition positioned Fernco as the leading manufacturer and distributor of flexible couplings in the world.

In 2015, Fernco proudly invested in a new 150,000 sq. ft. manufacturing and distribution center in Davison, MI, along with state-of-the-art electric injection machines. Located a mile from previous facility, the center will allow Fernco to focus on additional product development and continue delivering exceptional customer service for the next fifty years.

Fernco's continuous growth is not to become the biggest company, but the best company. With resources from around the world, Fernco is able to create products that will meet the needs of the individual and the industry. It all comes down to Fernco's focus on the individual customer to provide a product that can be trusted with confidence.



150,000 sq. ft. manufacturing and distribution facility



## Global Manufacturing



United States



Canada



United Kingdom



Germany



Australia

## Global Distribution



United States



Canada



European Union



Australia



New Zealand



Puerto Rico



Mexico



Brazil



## Standard Flexible Couplings



For a coupling to perform like a Fernco,

---

**IT MUST SAY FERNCO.**

Manufactured of tough elastomeric polyvinyl chloride (PVC), Fernco couplings are strong, resilient and not affected by soil conditions. Due to the nature and physical properties of their material, they are also resistant to chemicals, ultra-violet rays, fungus growth and normal sewer gases. And they are leak-proof, rot-proof and seal against infiltration and exfiltration.

Because of their quality and ease of installation, Fernco flexible couplings have found approval among plumbers, contractors and municipalities across the globe. Fernco couplings are used for all types of in-house and sewer applications such as drain, waste, vent piping, house-to-main, cut-ins, conductors, roof-drains and more.

All couplings are clearly marked with part number, size, and the materials that the coupling will connect to. Fernco has fast lead times with no minimum order required. For special applications, our custom design service can supply couplings for individual customer requirements. Our Flexible Couplings are the industry standard.





1056-075 coupling  
shown at  
approximately  
actual size  
of 2 3/8" high

Fernco's specially formulated PVC compound positively seals any sewer and drain connection.

Fernco makes the most complete line of couplings in the industry, from sizes 3/4" and larger. Custom large diameter couplings are available, along with shielded transitional couplings to ensure all pipes, underground and above-ground, can be connected with a Fernco coupling. Because Fernco couplings have earned a reputation for superior performance, you can have full confidence in their quality and reliability.

Tested designs backed by over five decades of proven experience

Available from 3/4" and larger

- Seals against infiltration and exfiltration
- Leak-proof, root-proof and resistant to many chemicals, ultra violet rays, fungus growth and normal sewer gas
- Conforms to ASTM D 5926, C 1173 and CSA B602
- Connects pipes of same or different materials and sizes
- Corrosion-resistant and rust-proof stainless steel clamps
- Made of elastomeric polyvinyl chloride (PVC)
- 4.3 PSI maximum test pressure
- 140°F maximum intermittent operating temperature
- 120°F maximum consistent operating temperature



Flexible Couplings

## High Torque Clamps

STANDARD on all 18" and larger couplings

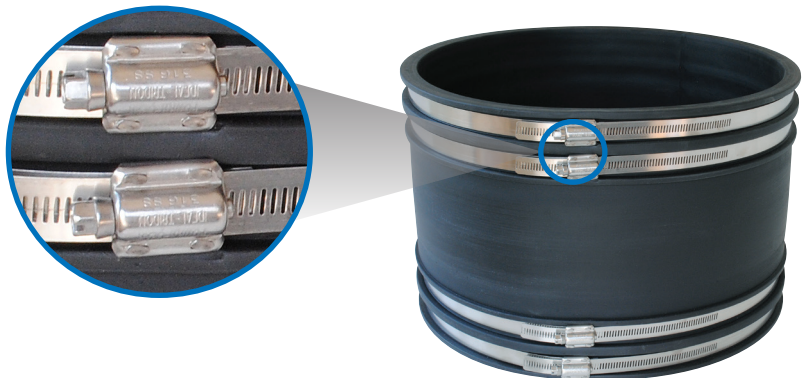

# PROFLEX®

Specialty Couplings By *Fernco, Inc.* 

## Above-ground transition couplings that create resilient pipe joints.

Connects ½" - 8" cast iron, plastic, steel, copper and tubular pipe

### Technical Data

**Proflex Shielded Couplings:** ASTM C 1460 and CSA B602  
**Gasket Material:** Neoprene - ASTM C 564

#### Shield Assembly Requirements

**Clamp:** 300 stainless steel

Band - 301 stainless steel .025 x .500 x length

Housing - 301 stainless steel

Screw - 305 stainless steel 5/16" hex - no slot

**Shield:** 301 stainless steel .012 x 2.125 x length

**Eyelet:** 305 stainless steel

**Installation Torque:** 60 in-lbs. installation torque

**Maximum test pressure:** 4.3 psi

**Maximum operating temperature:** 180° F



Shielded design to resist shear forces above-ground



### 3000 Series : CI to PL, ST, XHCI

Part Number	Description
3000-150	1.5" CI, PL or ST to 1.5" CI, PL, ST
3000-215	2" CI, PL, ST or XHCI to 1.5" CI, PL, ST
3000-22	2" CI, PL, ST or XHCI to 2" CI, PL, ST or XHCI
3000-33	3" CI to 3" PL, ST, XHCI
3000-43	4" CI to 3" PL, ST, XHCI
3000-44	4" CI to 4" PL, ST, XHCI
3000-55	5" CI to 5" PL, ST, XHCI
3000-66	6" CI to 6" PL, ST, XHCI
3000-88	8" CI to 8" PL, ST, XHCI

### 3001 Series : CI to CPR

Part Number	Description
3001-110	1.5" CI, PL or ST to 1" CPR or 3/4" PL
3001-1125	1.5" CI, PL or ST to 1.25" CPR or 1" PL
3001-150	1.5" CI, PL, ST to 1.5" CPR or 1.25" PL
3001-2125	2" CI, PL, ST to 1.25" CPR or 1" PL
3001-215	2" CI, PL, ST to 1.5" CPR or 1.25" PL
3001-22	2" CI, PL or ST to 2" CPR
3001-315	3" CI to 1.5" CPR or 1.25" PL
3001-32	3" CI to 2" CPR
3001-33	3" CI to 3" CPR
3001-43	4" CI to 3" CPR
3001-44	4" CI to 4" CPR

### 3002 Series : CI, PL, ST to Tubular

Part Number	Description
3002-150	1.5" CI, PL or ST to 1.5" Tubular
3002-155	1.5" Tubular to 1.5" Tubular
3002-215	2" CI, PL or ST to 1.5" Tubular

### 3003 Series : CPR to CPR

Part Number	Description
3003-150	1.5" CPR to 1.5" CPR or 1.25" PL
3003-215	2" CPR to 1.5" CPR or 1.25" PL
3003-22	2" CPR to 2" CPR
3003-33	3" CPR to 3" CPR

### 3004 Series : CI to CI, PL or ST

Part Number	Description
3004-320	3" CI to 2" CI, PL or ST
3004-420	4" CI to 2" CI, PL or ST
3004-430	4" CI to 3" CI
3004-540	5" CI to 4" CI

### 3005 Series : PL, ST or XHCI to PL, ST or XHCI

Part Number	Description
3005-33	3" PL, ST or XHCI to 3" PL, ST or XHCI
3005-43	4" PL, ST or XHCI to 3" PL, ST or XHCI
3005-44	4" PL, ST or XHCI to 4" PL, ST or XHCI
3005-66	6" PL, ST or XHCI to 6" PL, ST or XHCI

### 3006 Series : CPR to CI, PL or ST

Part Number	Description
3006-215	2" CPR to 1.5" CI, PL, or ST
3006-32	3" CPR to 2" CI, PL or ST
3006-43	4" CPR to 3" CI

### 3007 Series : PL, ST or XHCI to CPR

Part Number	Description
3007-32	3" PL, ST or XHCI to 2" CPR
3007-33	3" PL, ST or XHCI to 3" CPR
3007-43	4" PL, ST or XHCI to 3" CPR
3007-44	4" PL, ST or XHCI to 4" CPR

### 3008 Series : PL, ST or XHCI to CI, PL or ST

Part Number	Description
3008-32	3" PL, ST or XHCI to 2" CI, PL or ST

### 3009 Series : Thinwall PL to Sch.40 PL

Part Number	Description
3009-33	3" Thinwall PL to 3" Sch.40 PL
3009-44	4" Thinwall PL to 4" Sch.40 PL

### 3010 Series: CPR to Tubular

Part Number	Description
3010-150	1.5" CPR to 1.5" Tubular
3010-215	2" CPR to 1.5" Tubular

NHCI: No-Hub Cast Iron  
 PL: Sch 40. Plastic  
 ST: Steel (IPS)  
 XHCI: Extra-Heavy Cast Iron  
 CPR: Copper



Flexible Couplings



# STRONG BACK

## 1000 RC Series



Flexible Couplings

### Technical Data

#### Gasket

- Meets the material requirements of:
  - CSA B602
  - ASTM D 5926
  - ASTM C 1173
- Hardness, Shore "A", Inst. +5.....65
- Tensile Strength, Min. psi....1000
- Tear Strength, Min.....150 lbf/in
- Brittleness Temperature.....-40°F

#### 1000 RC Series Clamps

- Clamp housing - 301 stainless steel
- Clamp Band - 301 stainless steel
- Clamp screw - 305 stainless steel
- Installation torque 60 lb/in
- High torque clamps installation torque 120 lb/in where applicable

#### NEW 6000 RC Series

- American Iron and Steel (AIS) Compliant

#### Shear Ring

- .012" Thick, 300 Series Stainless Steel
- Width manufactured according to coupling width (1.5", 2.13" or 4")
- Length manufactured according to coupling diameter
- Clamps spot welded in place

#### Coupling

- Manufactured to conform to the performance requirements of:



- 140°F maximum intermittent operating temperature
- 120°F maximum consistent operating temperature



Shear Resistance Test using an unshielded sewer coupling per ASTM C 1173 applied load 50 lbs per nominal inch of pipe diameter

Shear Resistance Test using a Fernco 1000 RC coupling per ASTM C 1173 applied load 50 lbs. per nominal inch of pipe diameter



Worm Gear Clamps

# RC COUPLINGS

## 5000 RC Series



Nut and Bolt Clamps



### Technical Data

#### Gasket

- Meets the material requirements of:
  - CSA B602
  - ASTM D 5926
  - ASTM C 1173
- Hardness, Shore "A", Inst. +5.....65
- Tensile Strength, Min. psi....1000
- Tear Strength, Min.....150 lbf/in
- Brittleness Temperature.....-40°F

#### 5000 RC Series Clamps

- Clamp Band - 316 stainless steel
- 6" and larger couplings incorporate two nut and bolt take-up points per band
- Installation torque 60 lb/in

#### Shear Ring

- .012" Thick, 300 Series Stainless Steel
- Width manufactured according to coupling width (1.5", 2.13" or 4")
- Length manufactured according to coupling diameter
- Clamps spot welded in place

#### Coupling

- Manufactured to conform to the performance requirements of:



- 140°F maximum intermittent operating temperature
- 120°F maximum consistent operating temperature

**CUSTOM CONNECTIONS**

Any size, any material.

Designed to resist heavy earth loads and shear forces underground while providing improved pipe alignment

Flexible Couplings

# XL COUPLINGS

## EXTRA Length for EXTRA Strength

Create greater confidence in your extreme condition pipe connections. The Fernco XL Coupling is built longer to be stronger, and more durable than any other coupling in the market.

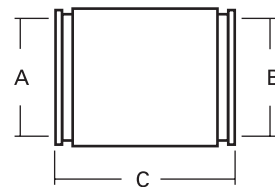

### Technical Specs

#### Gasket

- Manufactured to the requirements of:
  - ASTM C 1173
  - ASTM D 5926
  - CSA B602
- Hardness, Shore "A", Inst.  $\pm 5$  ..... 65
- Tensile Strength, Min. psi..... 1000
- Elongation at Rupture, Min. %..... 250
- Tear Strength, Min ..... 150 in/lb.
- Brittleness Temperature ..... -40°F

#### Clamps

- 300 Series Stainless Steel
- Installation torque..... 60 in/lb.

#### Shear Ring

- .012" thick, 300 Series Stainless Steel

#### Coupling

- Manufactured to the requirements of:
  - ASTM C 1173

Flexible Couplings

Part Number	Description	A	B	C
		in.	in.	in.
*1056-1502	1 1/2" CI/PL/Steel to 1 1/2" CI/PL/Steel	1.90	1.90	6.88
*1056-1502RC	1 1/2" CI/PL/Steel to 1 1/2" CI/PL/Steel	1.90	1.90	6.88
*1056-222	2" CI/PL/Steel to 2" CI/PL/Steel	2.38	2.38	7.75
*1056-222RC	2" CI/PL/Steel to 2" CI/PL/Steel	2.38	2.38	7.75
*1056-332	3" CI/PL/Steel to 3" CI/PL/Steel	3.40	3.40	7.75
*1056-332RC	3" CI/PL/Steel to 3" CI/PL/Steel	3.40	3.40	7.75
*1056-442	4" CI/PL/Steel to 4" CI/PL/Steel	4.40	4.40	7.75
*1056-442RC	4" CI/PL/Steel to 4" CI/PL/Steel	4.40	4.40	7.75
*1056-443	4" CI/PL/Steel to 4" CI/PL/Steel	4.40	4.40	11.63
*1056-443RC	4" CI/PL/Steel to 4" CI/PL/Steel	4.40	4.40	11.63
*1056-552	5" CI/PL/Steel to 5" CI/PL/Steel	5.51	5.51	7.85
*1056-552RC	5" CI/PL/Steel to 5" CI/PL/Steel	5.51	5.51	7.85

Part Number	Description	A	B	C
		in.	in.	in.
1056-662RC	6" CI/PL to 6" CI/PL	6.63	6.63	10.00
1056-882	8" CI/PL to 8" CI/PL	8.64	8.64	10.00
1056-882RC	8" CI/PL to 8" CI/PL	8.64	8.64	10.00
1056-10102	10" CI/PL to 10" CI/PL	10.75	10.75	10.00
1056-10102RC	10" CI/PL to 10" CI/PL	10.75	10.75	10.00
1056-12122	12" CI/PL to 10" CI/PL	12.75	12.75	10.00
1056-12122RC	12" CI/PL to 10" CI/PL	12.75	12.75	10.00
1002-442RC	4" Clay to 4" PL/CI	5.40	4.50	10.00
1002-662RC	6" Clay to 6" PL/CI	7.50	6.60	10.00
1002-882RC	8" Clay to 8" PL/CI	9.65	8.65	10.25
1002-10102RC	10" Clay to 10" PL/CI	12.50	10.50	10.25
1002-12122RC	12" Clay to 12" PL/CI	14.50	12.50	10.25

\*Equipped with two clamps per coupling - not including shield.



# Flexible Chemical Couplings



- Transitions dissimilar chemical piping and sizes
- Chemical resistant drain system, connects chemical waste piping to chemical waste tanks
- One piece Fluoropolymer (FEP) liner
- Suitable for above & below ground use
- Max temp: 212° F consistent, 266° F intermittent
- 4.3 PSI maximum test pressure

Fernco Chemical Couplings provide a flexible and watertight connection on drainage systems that require a high chemical resistance to a wide range of chemicals. Manufactured to meet specific site requirements, Fernco Chemical Couplings withstand the widest possible range of chemicals, due to the shear band and clamping bands encasing a high-performance elastomeric sleeve with a chemically resistant one-piece Fluoropolymer (FEP) liner and PTFE seals.

Part Number	Description	Min. Inch	Max. Inch
CC56G	1 1/2" PL/CI/GL	1.73"	2.09"
CC65G	2" PL/CI/GL or 1 1/2" DU	2.13"	2.60"
CC75G	2" DU or 2 1/2" PL	2.64"	3.11"
CC100G	3" PL/CI/GL	3.15"	3.50"
CC115G	3" DU/DI	3.54"	4.29"
CC125G	4" PL/CI/GL/DU/DI	4.33"	5.20"
CC180G	6" PL/CI/GL/DU/DI	6.22"	7.01"
CC225G	8" PL/CI/GL/DU/DI	8.35"	9.21"
CC275G	10" CI/GL	9.25"	10.59"
CC290G	10" PL/DU/DI	10.63"	12.09"
CC335G	12" PL/CI/GL	12.25"	12.75"
CC345G	12" DU/DI	12.75"	13.50"

Flexible Couplings

## Installation Steps:

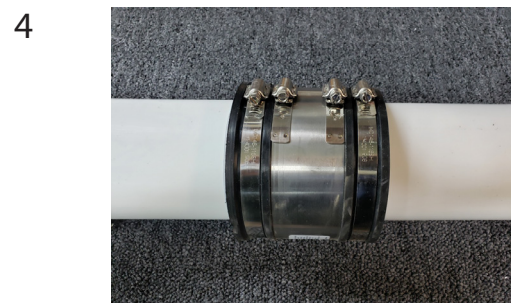
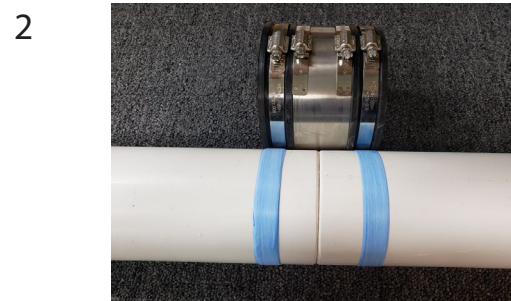
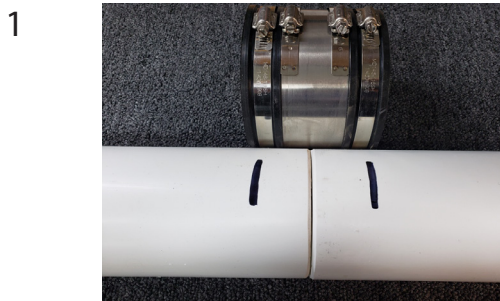

# Puddle Flange

- Stops Water Infiltration and Exfiltration
- Stops Radon Gas
- Easy Installation and Cost-Effective Solution
- Good Chemical Resistance
- Suitable for All Pipe Materials
- Install in Ceilings, Floors and Walls



## Molded

Part Number	Internal Dia.	Min. Pipe Size	Max. Pipe Size
FRK9602	.83	.63	.98
FRK9403	1.14	1.00	1.34
FRK9603	1.22	1.25	1.42
FRK9404	1.50	1.50	1.77
FRK9405	1.89	1.90	2.13
FRK9406	2.36	2.30	2.72
FRK9407	2.80	2.83	3.19
FRK9409	3.31	3.25	3.78
FRK9609	3.50	3.54	4.13
FRK9411	4.13	4.00	4.65
FRK9611	4.29	4.33	4.80
FRK9412	4.72	4.76	5.31
FRK9612	4.88	4.92	5.56
FRK9614	5.47	5.51	6.10
FRK9416	6.06	6.00	6.69
FRK9616	6.26	6.30	6.90
FRK9618	7.05	7.09	7.48
FRK9420	7.68	7.52	8.46
FRK9422	8.46	8.50	9.33
FRK9425	9.65	9.69	10.63
FRK9426	10.83	10.75	11.81
FRK9431	12.20	12.00	13.39
FRK9440	17.13	17.17	18.50

## Fabricated

Specify pipe OD when ordering

Part Number	Min. Pipe Size	Max. Pipe Size
FRK9503	11.81	15.73
FRK9504	15.74	19.67
FRK9505	19.68	23.61
FRK9506	23.62	27.54
FRK9507	27.55	31.48
FRK9508	31.49	35.42
FRK9509	35.43	39.36
FRK9510	39.37	43.29
FRK9511	43.30	47.23
FRK9512	47.24	51.00

- Fitted puddle flanges have an outside diameter  $\approx 4''$  larger than the pipe onto which they are installed (dependent on size)
- Concrete cover should be 2" against every surface around the puddle flange. Waterproof concrete should be used to ensure a water tight seal
- Puddle flanges do not provide axial restraint so they should not be used when axial loading on the pipe is present. The pipe has to be fully supported to withstand the concrete pouring process
- Tighten clamps to 60 in-lb torque

# No Hub Couplings

Engineered to connect No-Hub cast iron pipe



## Standard No-Hub

Conforms to CISPI 301 and complies with ASTM C 1277. Gasket meets the requirements of ASTM C 564. 60 in.lbs torque, 120 in.lbs for NH-1212 and NH-1515.

## Medium Duty No-Hub

Conforms to CISPI 310, Factory Mutual CN 1680 and complies with ASTM C564, ASTM C1540, IAPMO file #3198. Gasket meets the requirements of ASTM C564. 80 in.lbs torque. Easily identified with yellow color.

## Heavy Duty No-Hub

Conforms to CISPI 310, Factory Mutual EN 1680 and complies with ASTM C564, ASTM C1540, IAPMO file #3198. Gasket meets the requirements of ASTM C564. 80 in.lbs torque. Easily identified with green color.

Part Number	Size	Part Number	Size	Part Number	Size
NH-150	1-1/2"	MD-150	1-1/2"	HD-150	1-1/2"
NH-22	2"	MD-22	2"	HD-22	2"
NH-33	3"	MD-33	3"	HD-33	3"
NH-44	4"	MD-44	4"	HD-44	4"
NH-55	5"	MD-55	5"	HD-55	5"
NH-66	6"	MD-66	6"	HD-66	6"
NH-88	8"	MD-88	8"	HD-88	8"
NH-1010	10"	MD-1010	10"	HD-1010	10"
NH-1212	12"				
NH-1515	15"				

# Plastic Socket

Socket-to-socket and socket-to-pipe connections



Plastic Socket to Plastic Pipe

A B C

Part Number	in.	mm	in.	mm	in.	mm
1059-150	2.26	57	1.97	50	3.90	99
*1059-215	2.69	68	1.90	48	3.91	99
1059-22	2.70	69	2.40	61	3.91	99
*1059-32	3.99	101	2.38	60	3.99	101
1059-33	3.99	101	3.49	89	3.99	101
*1059-42	5.01	127	2.38	60	3.99	101
*1059-43	5.01	127	3.38	86	3.99	101
1059-44	5.01	127	4.50	114	3.99	101



Plastic Socket to Plastic Socket

A B C

Part Number	in.	mm	in.	mm	in.	mm
1060-150	2.26	57	2.26	57	3.92	100
1060-22	2.70	69	2.70	69	3.95	100
1060-33	3.94	100	3.94	100	3.97	101
1060-44	5.01	127	5.01	127	3.97	101

## Technical Data

- Compatible with plastic traps
- Shorten length to 3" or 2"
- Maximum pressure: 4.3 PSI

Flexible Couplings

# Pipe Sleeves

Seal pipe sleeves and carrier pipes

Part Number	Pipe Sleeve	Carrier Pipe
DTC110	1-1/2"	3/4", 1" plastic or 1" copper
DTC210	2"	3/4", 1" plastic or 1" copper
1056-315	3"	1-1/2"
1056-32	3"	2"
1056-415	4"	1-1/2"
1056-42	4"	2"
1056-43	4"	3"



## Technical Data

- Above and below ground applications
- Maximum test pressure: 4.3 PSI
- Maximum operating temperature: 140°F intermittent
- Conforms to ASTM D5926, C1173 and CSA B602

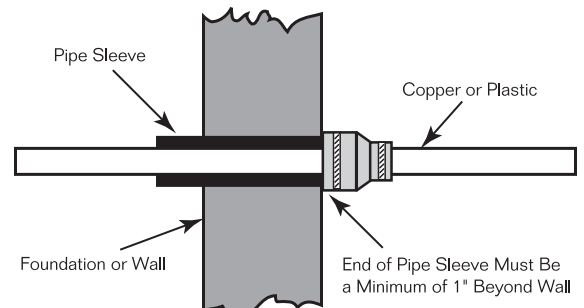



# Expansion Joints

## Thermal expansion and contraction of vertical pipes

### Technical Data

- Alternative for DWV offsets
- Residential and commercial applications
- Unique one-piece construction
- No moving parts to malfunction
- Positive positioning internal stops
- Applicable for drain, waste and vent stacks, and interior rain water conductor systems
- Accommodates a maximum of 1½" pipe expansion and ½" contraction from a normal position
- Above-ground use only



Stack installations for multi-story buildings

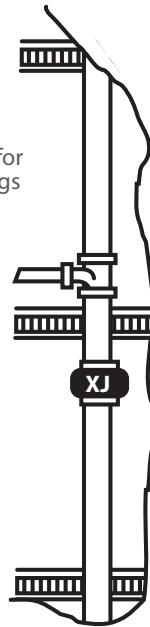
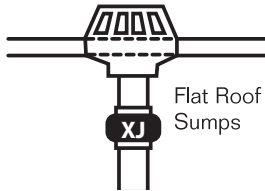

Part Number	Nominal Pipe Size
XJ-150	1-1/2" (38mm)
XJ-2	2" (50mm)
XJ-3	3" (76mm)
XJ-4	4" (101mm)

# Qwik Tee's and Ell's

Extra length for 90° and tee connections

### Technical Data

- Creates 90° connections
- Fits cast iron, plastic, steel, copper and lead pipe
- Conforms to ASTM D5926
- Length allows cut-out fittings
- Above-ground use only



Qwik Ells - CI, Copper, ST or Lead

Part Number	A		C	
	in.	mm	in.	mm
QL-150	1.90	48	1.90	48
QL-200	2.40	61	2.40	61
QL-300	3.50	89	3.50	89
QL-400	4.50	114	4.50	114



Qwik Tees - CI, PL, Copper, St or Lead

Part Number	A		B		C	
	in.	mm	in.	mm	in.	mm
QT-150	1.90	48	1.90	48	1.90	48
QT-200	2.40	61	2.40	61	2.40	61
QT-300	3.50	89	3.50	89	3.50	89
QT-400	4.50	114	4.50	114	4.50	114

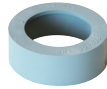

Qwik Bushing - Reducer

Part Number	A		B	
	in.	mm	in.	mm
QB-215	2.37	60	1.88	48
QB-32	3.41	87	2.31	59
QB-43	4.00	101	3.00	76

# Western Series Center Stop Couplings & Bushings

### Technical Data

- Bushings available for common 4", 6" and 8" transitions
- Sch. 40 PVC, ABS plastic and SDR-35 Plastic
- Bead, bald and plain-end cast iron
- Rough barrel and machined-end AC
- Ductile iron
- 300 series stainless steel band clamps, 316 available



### Couplings

Part Number	Size
1081-44	5.44" x 5.44" Clay to Clay
1081-66	8.00" x 8.00" Clay to Clay
1081-88	10.00" x 10.00" Clay to Clay
1085-88	9.00" x 9.00" AC x AC
1086-33	3.40" x 3.40" Cl or PL to Cl or PL
1086-44	4.56" x 4.56" Cl or PL to Cl or PL

### Bushings

Part Number	Size
481-2.38	5.38" x 2.38" Clay x PECl
481-3.38	5.38" x 3.38" Clay x PECl
481-3.50	5.38" x 3.50" Clay x Bead Cl, PL, XHCl
481-4.25	5.38" x 4.25" Clay x SDR-35 or PVC
481-4.38	5.38" x 4.39" Clay x PECl or Bald Cl (J)
481-4.50	5.38" x 4.50" Clay x ABS or Sch. 40
481-4.63	5.38" x 4.63" Clay x Bead Cl or MEAC (C)

481-4.90	5.38" x 4.90" Clay x RBAC or Cl 150 DI (B)
681-6.38	7.98" x 6.37" Clay x PECl or PVC (J)
681-6.63	7.98" x 6.62" Clay x ABS, Bead Cl, MEAC (C)
881-8.38	10.18" x 8.42" Clay x PECl or PVC (J)
881-8.63	10.18" x 9.00" Clay x ABS, Bead Cl, MEAC
881-9.00	10.18" x 9.00" Clay x RBAC or Cl 150 DI (B)
885-8.38	9.00" x 8.42" AC x PECl or PVC
885-8.63	9.00" x 8.64" Clay x ABS, Bead Cl, MEAC

Flexible Couplings

# Corrugated Pipe Couplings

Connect ADS and Hancor corrugated polyethylene to plastic



## Technical Data

- Available in 3", 4" 6" and 8" sizes
- Conforms to ASTM D5926
- Connects corrugated polyethylene drainage and irrigation systems to sewer, drain or DWV plastic pipe



Part Number	A		B		C	
	in.	mm	in.	mm	in.	mm
*1070-32	3.57	91	2.38	60	3.96	101
1070-33	3.57	91	3.44	87	3.96	101
*1070-42	4.76	121	2.38	60	3.94	100
*1070-43	4.76	121	3.38	86	3.94	100
1070-44	4.76	121	4.29	109	3.94	100
*1070-63	6.83	173	3.38	86	5.91	150
*1070-64	6.83	173	4.38	111	5.91	150
*1070-65	6.83	173	5.50	140	5.91	150
1070-66	6.83	174	6.50	165	5.91	150
*1070-84	9.76	248	4.38	111	5.70	145
*1070-86	9.76	248	6.38	162	5.70	145
1070-88	9.76	248	8.42	214	5.70	145

# HTRC Corrugated Pipe Couplings

Large diameter corrugated pipe couplings 10" to 60"

## Technical Data

- **Shear Resistance:** .012" (12mil) 300 series stainless steel sheer ring
- **High Torque Clamps:** 301 series stainless steel high torque clamps
  - 10" couplings are 6" wide with two clamp areas
  - 12" and larger couplings are 10" wide with 4 clamp areas.
- **Sealing Gasket:** The flexible PVC gasket has a smooth inside surface to provide ultimate sealing performance, making 360° contact over its entire length.

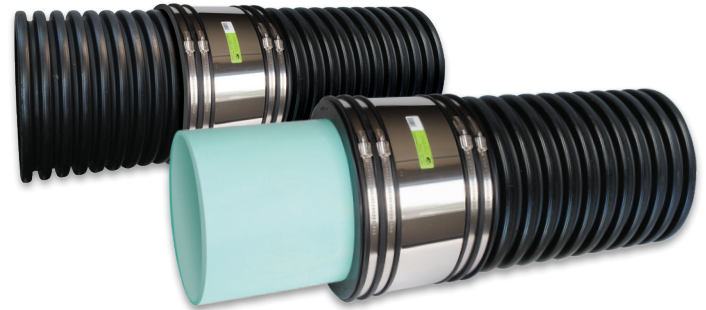

Flexible Couplings

## Greater sealing force on corrugated pipe

Additional sizes available upon request.

### Corrugated Polyethylene to Plastic

Part Number	A		B		C	
	in.	mm	in.	mm	in.	mm
*1070-10-8HTRC	11.6	295	8.4	213	6.0	152
*1070-1010HTRC	11.6	295	10.5	267	6.0	152
*1070-1210HTRC	14.4	366	10.5	267	10.0	254
*1070-1212HTRC	14.4	366	12.5	318	10.0	254
*1070-1515HTRC	17.7	450	15.3	389	10.0	254
*1070-1818HTRC	21.3	541	18.7	475	10.0	254
*1070-2424HTRC	28.1	714	24.8	630	10.0	254
*1070-3030HTRC	35.4	899	31.5	800	10.0	254
*1070-3636HTRC	41.6	1057	39.4	1001	10.0	254
*1070-4242HTRC	47.7	1212	44.5	1130	10.0	254
*1070-4848HTRC	54.1	1374	50.8	1290	10.0	254

### Corrugated Polyethylene to Corrugated Polyethylene

Part Number	A		B		C	
	in.	mm	in.	mm	in.	mm
1071-1010HTRC	11.6	295	11.6	295	6.0	152
1071-1212HTRC	14.4	366	14.4	366	10.0	254
1071-1515HTRC	17.7	450	17.7	450	10.0	254
1071-1818HTRC	21.3	541	21.3	541	10.0	254
1071-2424HTRC	28.1	714	28.1	714	10.0	254
1071-3030HTRC	35.4	899	35.4	899	10.0	254
1071-3636HTRC	41.6	1057	41.6	1057	10.0	254
1071-4242HTRC	47.7	1212	47.7	1212	10.0	254
1071-4848HTRC	54.1	1374	54.1	1374	10.0	254
1071-5454HTRC	61.0	1549	61.0	1549	10.0	254
1071-6060HTRC	66.8	1697	66.8	1697	10.0	254

## Ultra Rib Couplings

Effectively connect sewer pipe



ETI to SDR-35 Plastic

Part Number	A		B		C	
	in.	mm	in.	mm	in.	mm
1072-1212	14.00	355	14.00	355	9.89	251
1072-1515	16.80	427	16.80	427	9.89	251
1072-1818	20.30	515	20.30	515	10.00	2540
1072-2121	23.75	603	23.75	603	10.00	2540
1072-2424	26.75	680	26.75	680	10.00	2540



ETI to Asbestos Cement or Ductile Iron

Part Number	A		B		C	
	in.	mm	in.	mm	in.	mm
*1073-1212	14.00	355	12.25	311	9.89	251
*1073-1515	16.80	427	15.30	388	9.89	251
*1073-1818	20.30	515	18.75	476	10.32	262
*1073-2121	23.75	603	21.60	548	12.53	318
*1073-2424	26.00	660	24.80	630	10.00	2540

## Eccentric Bushings & Couplings

Maintain a continuous flow-line in critical grade conditions

### Technical Data

- Available for all common sewer pipe
- Aligns the inside wall of the two pipes
- Provides an obstruction free flow
- Meets ASTM C 1173 and D 5926
- 300 series stainless steel clamps
- Maximum test pressure 4.3 PSI

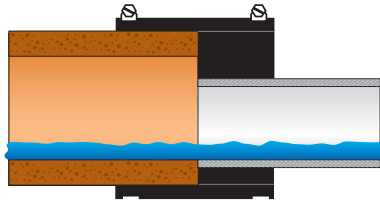

- **1002 EB**  
Clay to Cast Iron or Plastic
- **1006 EB**  
Concrete to Cast Iron or Plastic
- **1051 EB**  
AC or Ductile Iron to Cast Iron or Plastic
- **1055 EB**  
AC or Ductile Iron to AC or Ductile Iron
- **1056 EB**  
Cast Iron, Plastic, Copper, Steel or Lead to Cast Iron, Plastic, Copper, Steel or Lead

## Large Diameter Couplings

For non-standard or special size applications

### Technical Data

- 10 inches wide
- 300 stainless steel high torque clamps with multiple take up points
- Up to 120-lbs of torque for greater sealing pressure

\*Where O.D. differences range from 1-1/4" - 12", a Fernco bushing system is available



The ideal coupling for repairs, alterations or rehabilitation of large diameter sewer pipe.

### CUSTOM CONNECTIONS

Any size, any material.

### Expanded Range LDC Couplings

- Connect pipe materials with O.D.'s up to 12"
- Interlocking bushing system
- Reduces customer cost by utilizing one coupling and bushing configuration
- Reduces multiple couplings and intermediate pipe

\*Where O.D. differences range from 1-1/4" - 12", a Fernco bushing system is available





## Stainless Steel Clamps

9/16" to 16"



Series 316 stainless and high torque clamps are available upon request

Interlocked housing and band design strengthens under tension to ensure a positive seal. Bands have additional slots to accommodate greater dimensional range.

Part Number	For Diameters
012-300	9/16" to 1-1/4"
024-300	1-1/16" to 2"
028-300	1-5/16" to 2-1/4"
032-300	1-9/16" to 2-1/2"
038-300	1-15/16" to 2-7/8"
042-300	2-3/16" to 3-1/8"
044-300	2-5/16" to 3-1/4"
064-300	2-5/8" to 4-1/2"
080-300	3-5/8" to 5-1/2"
088-300	4-3/32" to 6"
096-300	4-1/2" to 6-1/2"

Part Number	For Diameters
104-300	5" to 7"
116-300	5-3/4" to 7-3/4"
128-300	6-1/2" to 8-1/2"
140-300	7" to 9-1/4"
152-300	8" to 10"
164-300	8-3/4" to 10-3/4"
184-300	10" to 12"
196-300	10-3/4" to 12-3/4"
212-300	11-3/4" to 13-3/4"
248-300	14" to 16"

## Torque Wrenches

Metal construction for 5/16" hex head screws, preset to 60 in. lbs. torque

Recommended for Fernco couplings and other banded Fernco products



**TW-100**  
Built-in reversing lever



**TW-200**  
Finger grip reversing collar

Flexible Couplings

## Custom Large Diameter Debris Caps

Custom fabricated from 14" and larger pipe O.D.

### Technical Data

- Reusable or permanent debris caps for pipe ends
- Designed for direct burial on non-pressurized horizontal pipe lines
- Strong two-piece construction
  - CAP Face: Rigid durable FPVC
  - Cap Body: Flexible PVC
  - Clamps: All 300 series stainless steel with 60"lb. installation torque
- Soil tight seal



**CUSTOM**  
Any size, any material.

**NOTE:** Not intended for use as a load bearing surface on vertically orientated pipe. Do not stand or step on cap surface if installed on vertically orientated pipe.

# Qwik Caps

## Quick, reusable caps for pipe ends, testing & cleanouts

### Technical Data

- Underground or above-ground applications
- Complies to ASTM D 5926
- 300 stainless steel clamps
- Maximum operating temperature: 140°F intermittent
- Maximum test pressure: 4.3 PSI
- Permanent seal



### Nominal Qwik Caps

Part Number	I.D.	Min.	Max.	Material
QC-101	1.90	1.75	2.00	1 1/2" PL, CI, Copper or ST
QC-102	2.40	2.25	2.60	2" PL, CI, Copper or ST or 1 1/2" Durion
QC-103	3.50	3.25	3.70	3" PL, CI, Copper or ST
QC-104	4.50	4.25	4.70	4" PL, CI, Copper, ST or Triple Wall
QC-105	5.60	5.35	5.80	5" PL, CI, Copper or ST or 4" Clay or Concrete
QC-106	6.60	6.35	6.80	6" PL, CI, Copper, ST or SS or 5" EC, OB, AC or Concrete
QC-108	8.50	8.25	8.70	8" PL, CI, Copper, ST or SS or 6" WC
QC-110 (TC-10)	10.47	9.88	11.00	10" PL, CI, Copper, ST or SS or 8" Concrete
QC-112	12.49	11.41	13.33	12" PL, CI, ST, Ductile or AC or 10" WC, EC or Concrete

Part Number	I.D.	Min.	Max.	Material
QC-0.85	0.85	0.79	0.91	1/2" PL or ST or 3/4" Copper or SS
QC-1.07	1.07	1.00	1.12	3/4" PL or ST or 1" Copper or SS
QC-1.38	1.37	1.22	1.50	1" PL or ST or 1 1/4" Copper or SS
QC-1.68	1.68	1.37	1.87	1 1/4" PL or ST or 1 1/2" Copper or SS
QC-2.75	2.75	2.18	2.93	2" Durion
QC-3.75	3.76	3.29	4.00	3" Durion or 4" SS
QC-4.75	4.82	4.32	5.05	4" Durion, Ductile, OB or Corrugated or 5" SS
QC-7.00	6.96	6.44	7.25	5" WC or 6" Ductile, AC, OB or Corrugated
QC-9.00	9.01	8.59	9.34	8" Ductile, OB, AC or Corrugated
QC-9.75	9.75	9.29	10.00	8" WC or EC
QC-10.75	10.74	10.22	11.15	10" Ductile, AC or Corrugated
QC-14.00	14.00	13.23	14.30	12" Concrete or Clay or 14" PL

Qwik Caps offer a quick, easy way to cap pipe ends, cleanouts and test pipes. Made of flexible PVC, they are suitable for above-ground or underground applications on cast iron, steel, copper or plastic piping.

WC: West Coast Clay  
 EC: Eastern Standard Clay  
 OB: Orangeburg  
 PL: Plastic

CI: Cast Iron  
 AC: Asbestos Cement  
 ST: Steel  
 SS: Stainless Steel



## Fernco QwikSeal

Part Number	Pipe Inlet	Host Pipe Size Application
QS-4	4" SDR	8" diameter and larger pipe
QS-4S40	4" SCH-40	8" diameter and larger pipe
QS-6	6" SDR-35	10" diameter and larger pipe
QS-6S40	6" SCH-40	10" diameter and larger pipe
QS-8	8" SDR-35	15" diameter and larger pipe

### NOTE Corrugated Applications

- QS-4 and QS-4S40: 8" to 24" pipe diameter
- QS-6 and QS-6S40: 10" to 24" pipe diameter
- QS-8: 15" to 24" pipe diameter

## Fernco Hole Saws

Part Number	Description
QS-5x4HS	5" OD x 4" Deep Hole Saw with Arbor
QS-7x4HS	7" OD x 4" Deep Hole Saw with Arbor
QS-9x4HS	9" OD x 4" Deep Hole Saw with Arbor
QS-SAW5S	5" OD x 4" Deep Hole Saw
QS-SAW7S	7" OD x 4" Deep Hole Saw
QS-SAW9S	9" OD x 4" Deep Hole Saw
QS-ARBOR-S	3/8" x 6" Drill with 1/2" Arbor
QS-ADAPTER	1 1/4" x 3/4" Coring Machine Adapter

## Fernco Coring Bits

Part Number	Description
QS-5x14CB	5" OD x 14" Length Abrasive Coring Bit
QS-7x14CB	7" OD x 14" Length Abrasive Coring Bit
QS-9x14CB	9" OD x 14" Length Abrasive Coring Bit

Connect service pipe to solid wall, profile, closed profile and corrugated pipe with QwikSeal



## Technical Data

- Meets ASTM C 923
- When tested in concrete manholes
  - Creates water-tight, compression seal up to 10 PSI
  - Withstands up to 7° of deflection
- Easy color identification - gray Sch 40 - green SDR-26 & 35
- Independent of host pipe size, type or material
- Reduced complexity, many solutions with one QwikSeal
- Less inventory and more turns



# QwikSeal Installation



1. Core a perpendicular hole to the main line:  
 - 5" hole for 4" pipe inlet  
 - 7" hole for 6" pipe inlet  
 - 9" hole for 8" pipe inlet



2. Use sand paper or a file, clean and remove any burrs from opening.



3. Remove band clamp from QwikSeal, fold and insert into opening. Unfold.



4. Pull up on QwikSeal until it stops against the inside of the pipe.



5. Measure the depth of the QwikSeal, from the pipe stop to the top edge.



6. Measure the depth of the fitting to be attached pipe stub. See alternative method below.

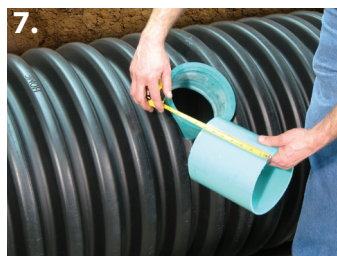

7. Add the dimensions of the QwikSeal and the fitting and cut a stub to that length.



8. Bevel the leading edge of the pipe stub for easier insertion into the QwikSeal.



9. Lubricate the QwikSeal and pipe stub.



10. Start the pipe stub into the QwikSeal by hand.



11. Using a hammer and block of wood, drive the pipe stub to the QwikSeal pipe stop.



12. Install the band clamp at 60 in-lbs. torque.



13. Install pipe fitting. Fitting should sit flush with the surface of the QwikSeal.



**Fitting and QwikSeal should be flush**

## Alternative Methods to Stub and Fitting

**Bell End Pipe:** You may also use the bell end of a piece of SDR-35 or SCH-40 instead of the stub and fitting method. After measuring the depth of the QwikSeal in step 5, transfer this measurement to the bell end of your inlet pipe, measuring from the bell. (Figure A) Proceed with steps 8 - 12.

**Street Fittings:** Street fittings may also be used with QwikSeal. (Figure B)

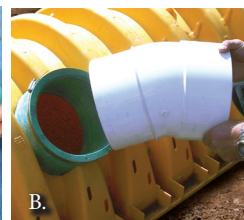

# Tap Saddles & Pressure Kit

## Tap Saddle Technical Data

- Conforms to ASTM D 5926
- Manufactured from a specially formulated high durometer PVC
- Includes special 300 series stainless steel 'slip-lock' clamps for a fast and simple installation on any type of pipe from 6"-15"\*
- A larger apron with locating ring fits 5" or 7" standard shell cutters
- Large band grooves
- Ensures a **soil-tight seal**
- Available for most 4" or 6" plastic or cast iron drain pipe inlets in **Tee** or **Wye** configurations
- 4" saddle fits 6" and larger host pipe
- 6" saddle fits 8" and larger host pipe

Part Number	Description
TST-4	4" CI or PL Inlet - Tee Tap Saddle
TST-6	6" CI or PL Inlet - Tee Tap Saddle
TSW-4	4" CI or PL Inlet - Wye Tap Saddle
TSW-6	6" CI or PL Inlet - Wye Tap Saddle
*312-300	Extension Clamps larger than 15" sewer mains



## TSPK Technical Data

- Bentonite tape provides a **water tight seal**
- Pressure tested to 10 PSI
- Coated steel reinforcing bars apply an even sealing pressure
- Includes two special 300 series stainless steel 'slip-lock' clamps for a fast and simple installation

Part Number	Description
TSPK-46	Pressure kit for Fernco Flexible Tap Saddles - Fits models: TST-4, TST-6, TSW-4, TSW-6

Flexible Tap Saddles provide a soil-tight seal. Use Fernco Tap Saddle Pressure Kit (TSPK-46) for a water-tight connection up to 10 PSI.

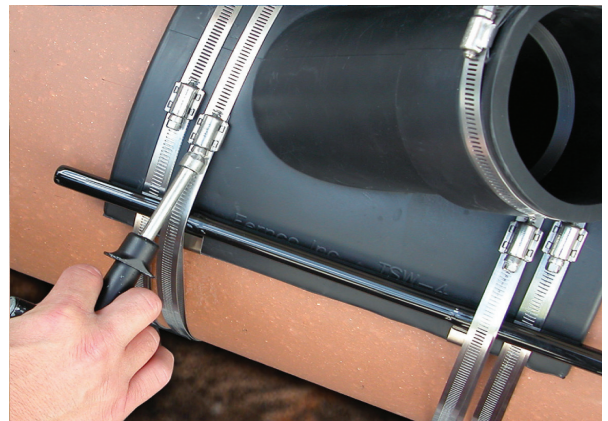



# ICON Coupling®

Internal Pushfit Connector - 4" & 6" Sewer Pipe and DWV



Simple, fast pushfit connection



Internal Seals

Product Code	Nominal Dia. (inch)	Description
IC44P	4	Connects two pipes having an I.D. range of: 3.90"-4.06"
IC66P	6	Connects two pipes having an I.D. range of: 5.83"-6.02"

## Benefits

- Internal Pushfit connection - no tools required
- Use where standard couplings cannot be used
- No need to expose external surface of pipe
- Can be removed and re-used
- Watertight connection on any pipe material
- Connects pipes of differing or irregular O.D.
- Pipe stop indicates proper installation
- Internal lip ensures smooth transition
- Rigid ABS Body provides excellent shear resistance
- Ideal for the connection of plastic (SDR 35, Sch 40), Cast Iron and Copper. Does not work for SDR-26
- 4.3 PSI test pressure

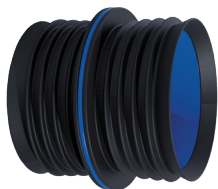

1) Clean and measure pipe I.D.



2) Lubricate gasket O.D. with soap & water solution



3) Push in place up to the pipe stop



4) Lubricate gasket and install 2nd pipe

Ensure that the tapered edge on the rubber sleeve does not fold back when inserting into the pipe.



## Fernco Donuts

### Sewer pipe compression joint seal

Fernco Donuts are flexible PVC donut-shaped rings for the compression sealing of sewer pipe joints and DWV connections such as sockets, hubs, bells and spigots.



Fernco Donuts are available in hundreds of sizes and configurations to use with most brands and types of piping material.

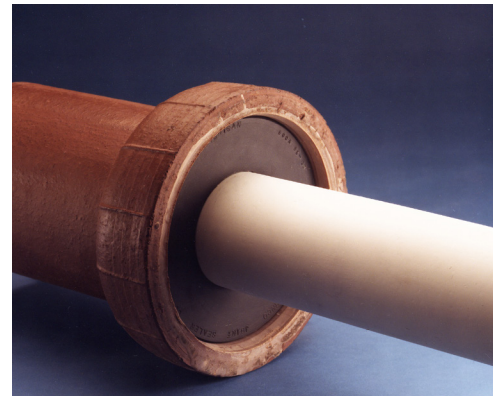

**Give us a call.**  
Our sales coordinators are trained to assist you in making the right part selection.

## O-Rings

### Connects 4" house pipe to 6" sewer pipe

O-rings provide a quick, simple solution to create secure connections between most 4" house pipe and 6" sewer pipe.

#### Technical Data

- Meets ASTM C 443 and C 425
- Connects CI or plastic house pipe to clay, plastic, concrete or A/C sewer pipe

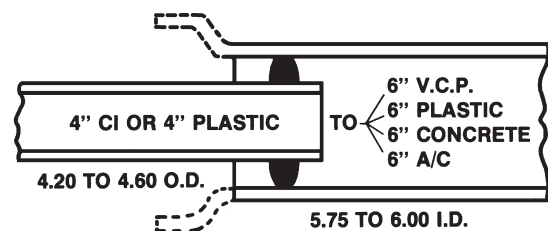

Installs quickly and easily.  
For 4.20" - 4.60" O.D. house pipe  
Fits 5.75" - 6.00" I.D. sewer pipe

Part Number	Description
BR-64	Rolling style rubber O-Ring

## Multi-Tite Pipe Gaskets

Pipe gasket for service weight cast iron pipe

### Technical Data

- Meets ASTM C564
- Multi rings on the outside create an easy installation
- Seals sewer pipe joints and connections such as sockets, hubs, bells and spigots

Part Number	Description
SVG-2	2" service weight cast iron
SVG-3	3" service weight cast iron
SVG-4	4" service weight cast iron
SVG-5	5" service weight cast iron
SVG-6	6" service weight cast iron
SVG-8	8" service weight cast iron
SVG-10	10" service weight cast iron
SVG-12	12" service weight cast iron
SVG-15	15" service weight cast iron

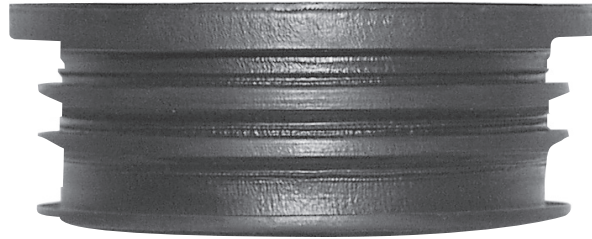

## Concrete Manhole Adapters

Eliminate leaks around pipes entering manhole walls

CMA's and LDCMA's are corrosion proof and unaffected by acid or alkali, however may be subjected to various conditions that are beyond the manufacturers control. Discretion must be used in it's application and installation. CMA's are designed for cast iron and plastic connections and the LDCMA's are custom fabricated to size.

Part Number	Description
4 CMA	4" I.D. Pipe
6 CMA	6" I.D. Pipe
8 CMA	8" I.D. Pipe
10 CMA	10" I.D. Pipe
12 CMA	12" I.D. Pipe



For custom sizes, order by specifying the pipe O.D. which is to receive the adapter. Minimum size: 8.5 inches O.D.

Due to the factors that can influence the effectiveness as a seal, Fernco does not warrant this product as a positive seal.

# Wax Free Toilet Seal

Residential and commercial applications in three ideal sizes

### Technical Data

- Strong and flexible to sustain a seal
- Accommodates floors above the toilet flange to 3/4"
- Maintains a gas tight seal even when minor movement occurs
- Impervious to mold and mildew
- Centers itself and the toilet to drain
- Ideal for in-floor radiant heat systems
- Fast, easy installation
- Long-term solution



Part Number	Description
FTS-3	Wax Free Toilet Seal for 3" Drain Pipe
FTS-4	Wax Free Toilet Seal for 4" Drain Pipe
FTS-4CF	Wax Free Toilet Seal for 3.5" Flange and 4" Drain Pipe

The FTS-3 Wax Free Toilet Seal

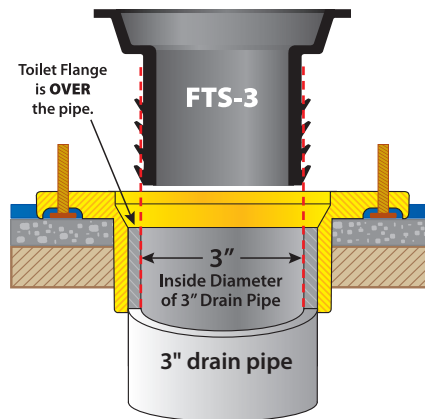

The FTS-4 Wax Free Toilet Seal

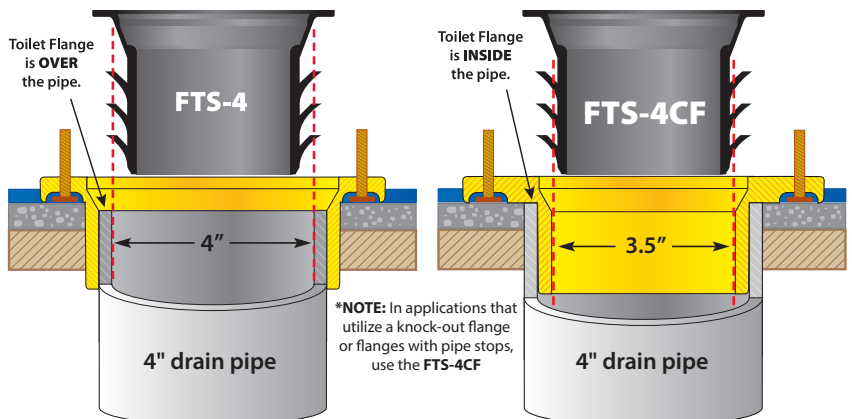

Internal Seals

# Wax Free Urinal Seal

Fast, reliable & leak-free



### Technical Data

- Strong and flexible to sustain a positive seal
- Ideal for new installations and replacements
- Maintains a gas, water and odor tight seal
- Fast, easy installation for a long-term seal
- Impervious to mold and mildew
- Reusable on the same urinal
- Will flex with minor movement

CONFORMS TO  
ASTM A 1045



Part Number	Description
FUS-2	Wax Free Urinal Seal for 2" Drain Pipe

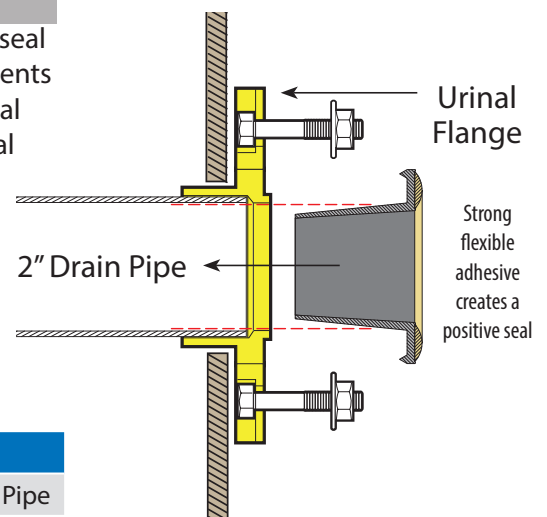





# Ultimate Drainage Solution

StormDrain Plus ensures a long-lasting, permanent solution to the collection and dispersal of standing surface water.

## Technical Data

- Designed to withstand automotive weight for Class B (loads of 61-175 psi), medium-duty pneumatic tire traffic, autos and light trucks at speeds less than 20 mph.
- All products are "UV" inhibited
- Grates are ADA and heel guard compliant
- Grates have a non-slip textured surface
- Clips or screws are not required to assemble
- Concave grates trap and transfer water



Water Management

Part Number	Description
FSDP-CHGG	39.5" grey Channel with grate
FSDP-GP3G	Three pieces of grey Channel with grate, one End Cap and one End Outlet
FSDP-QUAD	Four-way connector
FSDP-EC	End Cap
FSDP-EO	End Outlet

Replacement Part Number	Description
FSDP-CH	Grey Channel ONLY
FSDP-GG	Grey grate ONLY

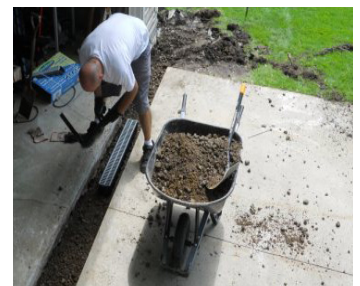

# STRONG & EASY

Ideal for driveways, patios, swimming pools, sports courts, gardens and more!

## Sump Pump Check Valve

Reduces sump pump wear and tear

Sump Pump Check Valves allow unrestricted water to flow through the pipes.



### Technical Data

- Full-flow, flapper design
- Eliminates back-flow and wear on pipe
- Durable thermoplastic body

Part Number	Description
CV-125T	1-1/4" male pipe thread x 1-1/2" or 1-1/4"
CV-150T	1-1/2" male pipe thread x 1-1/2" or 1-1/4"
CV-150	1-1/4" or 1-1/2" x 1-1/4" or 1-1/2"
CV-200	2" x 2"

## Water Well Debris Taps

Prevents loose debris from plugging pump suction area

### Technical Data

- Eliminates debris in the water well pump suction area
- Will not crack or become brittle
- Made of flexible PVC
- Conforms to drilled well irregularities



Part Number	Description
WC 500-238	2" casing x 5" well
WC 600-350	3" casing x 6" well
WC 600-450	4" casing x 6" well
WC 700-450	4" casing x 7" well
WC 700-562	5" casing x 7" well
WC 800-550	5" casing x 8" well
WC 900-550	5" casing x 9" well
WC 800-662	6" casing x 8" well
WC 1000-662	6" casing x 10" well

## Downspout Connectors

Seal out debris by connecting downspouts

Downspout Connectors stretch easily over most common downspouts to seal out debris. Ideal for aluminum, steel or plastic downspouts and cast iron, spiral, corrugated or plastic drain pipe.

Part Number	Description
UDSC-6C	6" Cap for DWV pipe exposed above ground, fitting the O.D. of PVC and CI and a 6" or less downspout
UDSC-6P	6" Plug for DWV pipe cut off at grade level, fitting any 6" I.D. sewer pipe and a 5.75" or less downspout

Part Number	Drain Pipe	Downspout
DSC-43	4"	3" x 2" rectangular, 3" round or
DSC-33	3"	2-1/2" square
DSC-534	4"	5" x 3" rectangular

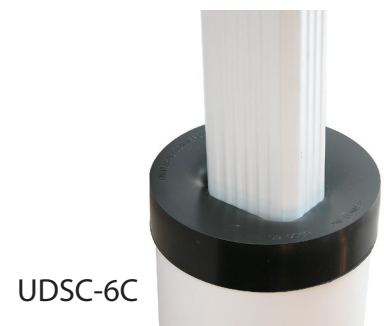
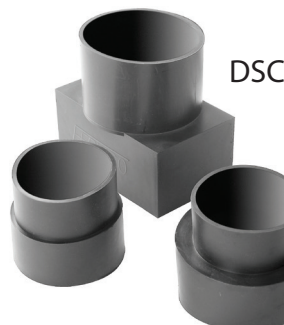





Pow-R Patch is a complete repair kit that includes a pre-coated fiberglass cloth in a self-contained mixing pouch and a pair of protective gloves.

### Technical Data

- Holds up to 100 PSI
- Heat resistant to 425°F

### Part Number Description

FP-P46	4" x 6" fiberglass and epoxy patch
--------	------------------------------------



Pow-R Wrap is a water activated fiberglass wrap that permanently repairs wet or dry pipe and hose. Pow-R Wrap is a self-contained kit including everything you need to repair a magnitude of applications.

### Technical Data

- Water activated
- Fiberglass wrap
- Heat resistant to 425°F
- Conforms to standard water main pressure test
- Cures in 30-60 mins.

Part Number	Description	Pipe Diameter
FPW248CS	2" x 48" wrap	Up to 1"
FPW3132CS	3" x 132" wrap	1-1/4" to 3"
FPW4252CS	4" x 252"	3" to 6"

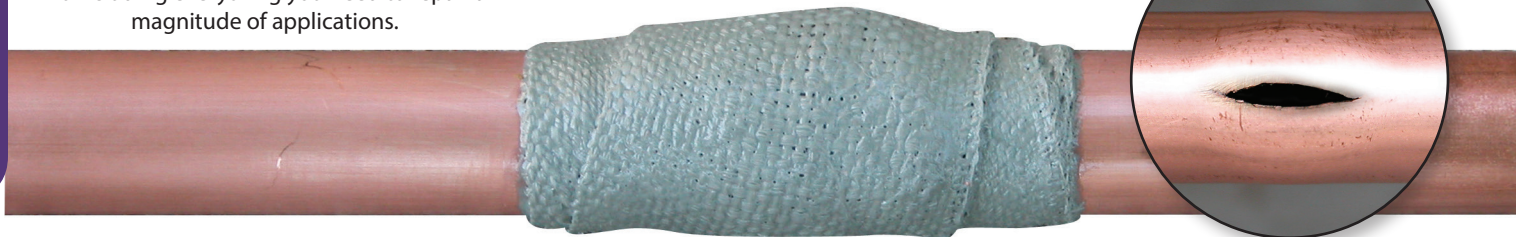

Sealants



Pow-R Wrap Industrial with Pow-R Belt is a permanent solution for large diameter pipes from 8"-50". Eliminate pipe replacement with hands-free cure time and a smooth, professional finish.

### Technical Data

- Heat resistant to 425°F
- Conforms to standard water main pressure test
- Cures in 60-90 mins. at 55°-75°F
- Safe for drinking water systems
- Repairs up to 1/4" W x 4" L
- Impervious to water, oil, and most chemicals, solvents and acids when cured



FPW8540S-1	1 KIT 8" X 540" Pow-R Wrap				
Pipe Outside Diameter	8"-18"	20"-24"	26"-34"	36"-42"	44"-50"
Number of Kits REQUIRED	1 KITS	2 KITS	3 KITS	4 KITS	5 KITS



## Hose Bibs

Reusable cap with hose bib for pipe ends and testing DWV systems

### Technical Data

- Permanent or temporary cap
- Convex shape allows the cap to withstand pressure and minimizes ballooning

Part Number	Nominal Pipe Size
HBC-1	1-1/2"
HBC-2	2"
HBC-3	3"
HBC-4	4"
HBC-5	5"
HBC-6	6"



## Flexible Qwik Traps

Replace plastic or metal drain traps

Qwik Traps replace 1-1/4" or 1-1/2" plastic or metal drain traps. The PVC material adjusts to the pipes misalignment and installs securely, creating a leak-free connection. To clean, simply squeeze the product!



1-1/4" or cut for 1-1/2" sink drain

Part Number	Description
FT-150	1-1/4" or 1-1/2" drain trap

Flexible Connectors

## Drain & Trap Connectors

Connect tubular traps to common household drain pipe

Drain & Trap Connectors are ideal for new installations, repairs and alterations. Eliminating traditional methods, this product has a quick installation that will leave drain & trap systems leak-free.



Part Number	Description
DTC-150	1-1/2" pipe x 1-1/2" or 1-1/4" tubular traps (use for 2" copper)
DTC-215	2" pipe x 1-1/2" or 1-1/4" tubular traps



## Tubular Drain Pipe Connectors

### Repair or alter tubular drain pipe

Fernco Tubular Drain Pipe Connectors offer a quick solution to extend, alter or repair any combination of 1-1/2" or 1-1/4" brass or plastic drain pipe. Whether connecting brass or plastic, the PVC material is formulated to provide a reliable connection that can be installed in minutes.



Part Number	Description
TC-150	1-1/4" or 1-1/2" tubular drain pipe

## Dishwasher Drain Connector

### Connect dishwasher hoses to sink drain or garbage disposals

Fernco Dishwasher Drain Connector connects a dishwasher hose to sink drains and garbage disposers. The strong, elastomeric PVC material is engineered to move with the connection for a leak free solution that will last for years.

Part Number	Description
DWC-100	1/2" x 3/4" dishwasher drain connector



## Shower Drain Connector

### Connect drain pipe to shower drain pipes

Fernco Shower Drain Connectors connect 2" DWV plastic, sch. 40 steel, or XHCl pipe to shower drain bodies. .

Part Number	Shower Drain Body
SD-200	American Brass & Aluminum, Armstrong (requires cutting to 3/4" height), Casper Model 101-101P, Casper Model 101 BR, Garvin Model 475, Intercon, Kohler, Schual Mfg. Brass Model 1524
SD-210	Mustee 1-piece molded shower base, Owens Corning 1-piece molded shower base



## Fix-A-Flange

### Repair broken toilet flanges

Fix-A-Flange eliminates the need to replace broken toilet flanges. Suitable for cast iron, plastic, copper and brass flanges, Fix-A-Flange offers a long-term solution to stop wobbly and leaky toilets.



Part Number	Description
SF-100	Fix-A-Flange toilet flange repair

## Utility Connectors

### Connect small drain lines to DWV plastic sockets

Fernco Utility Connectors are a one-piece connector with a simple press-fit installation.

Part Number	Description
UC-1550	1/2" CPVC or copper to 1-1/2" DWV plastic socket
UC-1575	3/4" CPVC or copper to 1-1/2" DWV plastic socket
UC-1510	1" CPVC or copper to 1-1/2" DWV plastic socket



**Note:** The Utility Connector is engineered to function in limited low-pressure applications (5 PSI or 12 ft. head.)  
**DO NOT USE** in pressure water systems.

Flexible Connectors

## Hose Grip Washer Connector

### Prevent accidental washer hose spills

The Fernco Hose Grip Washer Connector holds washing machine hoses securely in their standpipe drains.

Part Number	Description
HG-1	Fits 2" or 1-1/2" standpipe to 1" - 1-7/16" washer hose





NOMINAL PIPE SIZE (INCHES)	STANDARD RANGE "A" x "B"	1000 RC SERIES RANGE "A" x "B"	5000 RC SERIES RANGE "A" x "B"	ECCENTRIC RANGE "A" x "B"
4 x 4	<b>1001-44</b> 5.55 - 4.85 x 5.55 - 4.85	<b>1001-44RC</b> 5.55 - 4.85 x 5.55 - 4.85	<b>5001-44RC</b> 5.30 - 5.06 x 5.30 - 5.06	
4 x 4 WC	<b>1001-44WC</b> 5.85 - 5.15 x 5.85 - 5.15	<b>1001-44WCRC</b> 5.85 - 5.15 x 5.85 - 5.15	<b>5001-44WCRC</b> 5.60 - 5.36 x 5.60 - 5.36	
5 x 4	<b>use 1002-55</b>			
5 x 5	<b>1001-55</b> 6.35 - 5.65 x 6.35 - 5.65	<b>1001-55RC</b> 6.35 - 5.65 x 6.35 - 5.65		
6 x 4	<b>1001-64*</b> 7.60 - 7.00 x 5.80 - 5.10	<b>1001-64RC*</b> 7.75 - 7.00 x 5.75 - 5.00	<b>5001-64RC</b> 7.50 - 7.03 x 5.50 - 5.03	<b>1001-64EB*</b> 7.75 - 7.00 x 5.25 - 4.90
6 x 4 WC	<b>1001-64WC*</b> 8.25 - 7.50 x 5.65 - 5.05			
6 x 5	<b>use 1002-66</b>			
6 x 6	<b>1001-66</b> 7.75 - 7.00 x 7.75 - 7.05	<b>1001-66RC</b> 7.75 - 7.00 x 7.75 - 7.05	<b>5001-66RC</b> 7.50 - 7.03 x 7.50 - 7.03	
6 x 6 WC	<b>1001-66WC</b> 8.25 - 7.50 x 8.25 - 7.50	<b>1001-66WCRC</b> 8.25 - 7.50 x 8.25 - 7.50	<b>5001-66WCRC</b> 8.00 - 7.53 x 8.00 - 7.53	
8 x 4	<b>1001-84*</b> 10.05 - 9.30 x 5.30 - 4.90			
8 x 6	<b>1001-86*</b> 10.05 - 9.30 x 7.30 - 6.75	<b>1001-86RC*</b> 9.85 - 9.20 x 7.40 - 6.90		<b>1001-86EB*</b> 9.85 - 9.20 x 7.40 - 6.90
8 x 6 WC	<b>1001-86WC</b> 10.20 - 9.55 x 7.85 - 7.20	<b>1001-86WCRC*</b> 10.20 - 9.55 x 7.85 - 7.20		
8 x 8	<b>1001-88</b> 9.85 - 9.20 x 9.85 - 9.10	<b>1001-88RC</b> 9.85 - 9.20 x 9.85 - 9.10	<b>5001-88RC</b> 9.65 - 9.18 x 9.65 - 9.18	
8 x 8 WC	<b>1001-88WC</b> 10.20 - 9.55 x 10.20 - 9.55	<b>1001-88WCRC</b> 10.20 - 9.55 x 10.20 - 9.55	<b>5001-88WCRC</b> 10.00 - 9.53 x 10.00 - 9.53	
10 x 8	<b>1001-10-8*</b> 12.70 - 12.00 x 9.75 - 9.25	<b>1001-10-8RC*</b> 12.70 - 12.00 x 9.80 - 9.25		<b>1001-10-8EB*</b> 12.70 - 12.00 x 9.80 - 9.25
10 x 10	<b>1001-1010</b> 12.70 - 12.00 x 12.70 - 12.00	<b>1001-1010RC</b> 12.70 - 12.00 x 12.70 - 12.00	<b>5001-1010RC</b> 12.50 - 12.03 x 12.50 - 12.03	
10 x 10 WC	<b>use 1001-1010</b>	<b>1001-1010WCRC</b> 12.70 - 12.00 x 12.70 - 12.00	<b>5001-1010WCRC</b> 12.50 - 12.03 x 12.50 - 12.03	
12 x 10	<b>use 1002-1212</b>			
12 x 12	<b>1001-1212</b> 14.70 - 13.75 x 14.70 - 13.75	<b>1001-1212RC</b> 14.70 - 13.75 x 14.70 - 13.75	<b>5001-1212RC</b> 14.50 - 14.03 x 14.50 - 14.03	
12 x 12 WC	<b>use 1004-1212</b>	<b>1001-1212WCRC</b> 15.45 - 14.50 x 15.45 - 14.50	<b>5001-1212WCRC</b> 15.25 - 14.78 x 15.25 - 14.78	
15 x 10	<b>1001-1510*</b> 18.65 - 17.00 x 12.65 - 12.20	<b>1001-1510RC*</b> 18.65 - 17.15 x 12.65 - 12.20		
15 x 12	<b>1001-1512*</b> 18.30 - 17.00 x 14.50 - 13.60	<b>1001-1512RC*</b> 18.65 - 17.00 x 14.45 - 13.90		<b>1001-1512EB*</b> 18.65 - 17.00 x 14.45 - 13.90
15 x 15	<b>1001-1515</b> 18.65 - 17.15 x 18.65 - 17.15	<b>1001-1515RC</b> 18.65 - 17.15 x 18.65 - 17.15	<b>5001-1515RC</b> 18.15 - 17.68 x 18.15 - 17.68	
18 x 18	<b>1001-1818</b> 22.50 - 20.85 x 22.50 - 20.85	<b>1001-1818RC</b> 22.50 - 20.85 x 22.50 - 20.85	<b>5001-1818RC</b> 22.00 - 21.53 x 22.00 - 21.53	
21 x 21	<b>1001-2121</b> 25.25 - 23.00 x 25.25 - 23.00	<b>1001-2121RC</b> 25.25 - 23.00 x 25.25 - 23.00		
24 x 24	<b>1001-2424</b> 29.75 - 27.50 x 29.75 - 27.50	<b>1001-2424RC</b> 29.75 - 27.50 x 29.75 - 27.50		
27 x 27	<b>1001-2727</b> 33.15 - 30.90 x 33.15 - 30.90	<b>1001-2727RC</b> 33.15 - 30.90 x 33.15 - 30.90		

Resources

NOMINAL PIPE SIZE (INCHES)	STANDARD RANGE "A" x "B"	1000 RC SERIES RANGE "A" x "B"	5000 RC SERIES RANGE "A" x "B"	ECCENTRIC RANGE "A" x "B"
4 x 3	<b>1002-43</b> 5.40 - 4.75 x 3.50 - 3.20	<b>1002-43RC*</b> 5.55 - 4.85 x 3.55 - 3.30	<b>5002-43RC*</b> 5.55 - 4.85 x 3.55 - 3.30	<b>1002-43EB*</b> 5.55 - 4.85 x 3.55 - 3.30
4 x 4	<b>1002-44</b> 5.40 - 4.75 x 4.65 - 4.00	<b>1002-44RC</b> 5.55 - 5.00 x 4.60 - 4.00	<b>5002-44RC</b> 5.40 - 5.16 x 4.50 - 4.26	<b>1002-44EB</b> 5.40 - 4.75 x 4.55 - 3.95
4 x 4 WC	<b>1002-44WC</b> 5.60 - 5.00 x 4.60 - 4.10	<b>1002-44WCRC</b> 5.60 - 5.00 x 4.60 - 4.10	<b>5002-44WCRC*</b> 5.40 - 5.16 x 4.55 - 4.31	
4 x 4 SDR			<b>5002-44SDRRC*</b> 5.40 - 5.16 x 4.30 - 4.06	
4 x 6	<b>1002-46</b> 5.50 - 5.00 x 6.60 - 6.00	<b>1002-46RC*</b> 5.25 - 4.90 x 6.80 - 6.30	<b>5002-46RC*</b> 5.15 - 4.68 x 6.65 - 6.18	<b>1002-46EB*</b> 5.25 - 4.90 x 6.80 - 6.30
5 x 4	<b>1002-54*</b> 6.30 - 5.60 x 4.55 - 3.95	<b>1002-54RC*</b> 6.80 - 6.30 x 4.60 - 4.15		<b>1002-54EB*</b> 6.80 - 6.30 x 4.60 - 4.15
5 x 5	<b>1002-55</b> 6.30 - 5.60 x 5.70 - 5.30	<b>1002-55RC*</b> 6.80 - 6.30 x 5.65 - 5.20	<b>5002-55RC</b> 6.65 - 6.41 x 5.50 - 5.26	<b>1002-55EB*</b> 6.80 - 6.30 x 5.65 - 5.20
6 x 4	<b>1002-64</b> 7.50 - 6.90 x 4.50 - 3.85	<b>1002-64RC*</b> 7.75 - 7.00 x 4.70 - 4.15	<b>5002-64RC*</b> 7.50 - 7.03 x 4.50 - 4.03	<b>1002-64EC</b> 7.85 - 6.90 x 4.69 - 3.95
6 x 4 SDR		<b>1002-64SDRRC*</b> 7.75 - 7.00 x 4.70 - 4.05	<b>5002-64SDRRC*</b> 7.50 - 7.03 x 4.25 - 3.78	
6 x 4 WC	<b>1002-64WC*</b> 8.15 - 7.60 x 4.60 - 4.15	<b>1002-64WCRC*</b> 8.25 - 7.50 x 4.55 - 4.20	<b>5002-64WCRC*</b> 8.00 - 7.53 x 4.50 - 4.03	<b>1002-64WCEB*</b> 8.25 - 7.50 x 4.55 - 4.20
6 x 5	<b>1002-65</b> 7.60 - 7.00 x 5.80 - 5.10	<b>1002-65RC*</b> 7.75 - 7.00 x 5.70 - 5.30		<b>1002-65EB*</b> 7.75 - 7.00 x 5.70 - 5.30
6 x 6	<b>1002-66</b> 7.75 - 7.05 x 6.80 - 6.25	<b>1002-66RC</b> 7.75 - 8.05 x 6.80 - 7.25	<b>5002-66RC</b> 7.50 - 7.03 x 6.65 - 6.18	<b>1002-66EB*</b> 7.75 - 7.00 x 6.75 - 6.50
6 x 6 SDR		<b>1002-66SDRRC*</b> 7.75 - 7.00 x 6.50 - 6.00	<b>5002-66SDRRC*</b> 7.50 - 7.03 x 6.40 - 5.93	
6 x 6 WC	<b>1002-66WC</b> 8.15 - 7.45 x 6.80 - 6.10	<b>1002-66WCRC</b> 8.15 - 8.45 x 6.80 - 7.10	<b>5002-66WCRC</b> 8.00 - 7.53 x 6.65 - 6.18	
8 x 4	<b>1002-84*</b> 9.50 - 8.80 x 4.60 - 4.20	<b>1002-84RC*</b> 9.80 - 9.25 x 4.60 - 4.35		<b>1002-84EB*</b> 9.80 - 9.25 x 4.60 - 4.15
8 x 6	<b>1002-86</b> 9.50 - 8.80 x 6.35 - 5.70	<b>1002-86RC*</b> 9.75 - 9.25 x 6.75 - 6.50	<b>5002-86RC*</b> 9.65 - 9.18 x 6.65 - 6.18	<b>1002-86EB*</b> 9.80 - 9.25 x 6.75 - 6.50
8 x 6 WC	<b>1002-86WC*</b> 10.15 - 9.35 x 6.70 - 6.20	<b>1002-86WCRC*</b> 10.20 - 9.55 x 6.40 - 6.20		
8 x 8	<b>1002-88</b> 9.90 - 9.10 x 8.75 - 7.87	<b>1002-88RC</b> 10.00 - 8.95 x 8.66 - 7.94	<b>5002-88RC</b> 9.75 - 9.28 x 8.60 - 8.13	<b>1002-88EB*</b> 9.75 - 9.25 x 8.85 - 8.30
8 x 8 SDR			<b>5002-88SDRRC*</b> 9.65 - 9.18 x 8.65 - 8.18	
8 x 8 WC	<b>1002-88WC</b> 10.15 - 9.35 x 8.90 - 8.00	<b>1002-88WCRC</b> 9.90 - 9.30 x 8.40 - 8.15	<b>5002-88WCRC</b> 10.00 - 9.53 x 8.65 - 8.18	
10 x 8	<b>1002-10-8*</b> 12.70 - 12.00 x 8.85 - 8.30	<b>1002-10-8RC*</b> 12.70 - 12.00 x 8.85 - 8.30		<b>1002-10-8EB*</b> 12.70 - 12.00 x 8.85 - 8.30
10 x 10	<b>1002-1010</b> 12.70 - 12.00 x 10.75 - 9.75	<b>1002-1010RC*</b> 12.70 - 12.00 x 10.90 - 10.25	<b>5002-1010RC*</b> 12.50 - 12.03 x 10.75 - 10.28	<b>1002-1010EB*</b> 12.70 - 12.00 x 10.75 - 10.25
10 x 10 WC	<b>use 1006-1010</b>	<b>1002-1010WCRC*</b> 12.70 - 12.00 x 11.00 - 10.25	<b>5002-1010WCRC*</b> 12.50 - 12.03 x 10.75 - 10.28	
12 x 10	<b>1002-1210*</b> 14.70 - 13.75 x 11.00 - 10.30	<b>1002-1210RC*</b> 14.70 - 13.75 x 10.75 - 10.15		<b>1002-1210EB*</b> 14.70 - 13.75 x 10.75 - 10.15
12 x 12	<b>1002-1212</b> 14.70 - 13.75 x 12.75 - 11.75	<b>1002-1212RC</b> 14.70 - 13.75 x 12.75 - 11.95	<b>5002-1212RC</b> 14.50 - 14.03 x 12.60 - 12.13	<b>1002-1212EB*</b> 14.70 - 13.75 x 12.75 - 11.95
12 x 12 WC	<b>use 1006-1212</b>	<b>1002-1212WCRC*</b> 15.45 - 14.50 x 12.70 - 11.52	<b>5002-1212WCRC*</b> 15.25 - 14.78 x 12.35 - 11.88	
15 x 10	<b>1002-1510*</b> 18.30 - 17.00 x 10.75 - 10.10	<b>1002-1510RC*</b> 18.65 - 17.00 x 10.75 - 10.10		
15 x 12	<b>1002-1512*</b> 18.30 - 17.00 x 12.70 - 12.10	<b>1002-1512RC*</b> 18.65 - 17.00 x 12.70 - 12.10		<b>1002-1512EB*</b> 18.65 - 17.00 x 12.70 - 12.10
15 x 15	<b>1002-1515</b> 18.30 - 17.00 x 15.60 - 14.30	<b>1002-1515RC*</b> 18.65 - 17.00 x 15.55 - 15.00	<b>5002-1515RC*</b> 18.15 - 17.68 x 15.40 - 14.93	<b>1002-1515EB*</b> 18.65 - 17.00 x 15.55 - 15.00

<b>18 x 18</b>	<b>1002-1818</b> 22.20 - 21.50 x 19.00 - 18.30	<b>1002-1818RC*</b> 22.50 - 20.85 x 18.90 - 18.35	<b>5002-1818RC*</b> 22.00 - 21.53 x 18.80 - 18.33	
<b>21 x 21</b>	<b>1002-2121*</b> 24.80 - 23.30 x 22.40 - 21.80	<b>1002-2121RC*</b> 24.80 - 23.30 x 22.40 - 21.80		
<b>24 x 24</b>	<b>1002-2424*</b> 29.75 - 27.50 x 25.10 - 24.50	<b>1002-2424RC*</b> 29.75 - 27.50 x 25.10 - 24.50		
<b>27 x 27</b>	<b>1002-2727*</b> 32.90 - 31.40 x 28.35 - 27.75	<b>1002-2727RC*</b> 32.90 - 31.40 x 28.35 - 27.75	<b>5002-2727RC*</b> 32.40 - 31.93 x 28.25 - 27.78	

NOMINAL PIPE SIZE (INCHES)	STANDARD RANGE "A" x "B"	1000 RC SERIES RANGE "A" x "B"	5000 RC SERIES RANGE "A" x "B"	ECCENTRIC RANGE "A" x "B"
<b>4 x 4</b>	<b>1003-44</b> 5.45 - 4.90 x 4.90 - 4.40	<b>1003-44RC</b> 5.50 - 4.90 x 5.00 - 4.50	<b>5003-44RC</b> 5.30 - 5.06 x 4.85 - 4.61	
<b>4 x 4 WC</b>	<b>1003-44WC*</b> 5.85 - 5.15 x 5.15 - 4.50	<b>1003-44WCRC*</b> 5.85 - 5.15 x 5.15 - 4.50	<b>5003-44WCRC*</b> 5.60 - 5.36 x 4.95 - 4.71	
<b>4 x 6</b>	<b>use 1051-65</b>	<b>1003-46RC*</b> 5.25 - 4.95 x 7.10 - 6.35		
<b>5 x 4</b>	<b>1003-54*</b> 6.20 - 5.80 x 5.15 - 4.80	<b>1003-54RC*</b> 6.80 - 6.30 x 4.90 - 4.30		
<b>5 x 5</b>	<b>1003-55</b> 6.20 - 5.40 x 6.05 - 5.35			
<b>6 x 4</b>	<b>1003-64</b> 7.60 - 7.00 x 5.80 - 5.10	<b>1003-64RC*</b> 7.75 - 7.00 x 5.20 - 4.70		<b>1003-64EB*</b> 7.75 - 7.00 x 5.20 - 4.70
<b>6 x 4 WC</b>	<b>1003-64WC*</b> 8.25 - 7.50 x 5.10 - 4.65			
<b>6 x 5</b>	<b>1003-65*</b> 7.75 - 7.05 x 7.20 - 6.55			
<b>6 x 6</b>	<b>1003-66</b> 7.45 - 6.75 x 7.05 - 6.45	<b>1003-66RC</b> 7.50 - 6.85 x 6.05 - 6.60	<b>5003-66RC</b> 7.35 - 6.88 x 6.95 - 6.48	
<b>6 x 6 WC</b>	<b>1003-66WC*</b> 8.25 - 7.50 x 7.20 - 6.55	<b>1003-66WCRC</b> 8.25 - 7.50 x 7.20 - 6.55	<b>5003-66WCRC</b> 8.00 - 7.53 x 6.90 - 6.43	
<b>8 x 4</b>	<b>1003-84*</b> 9.90 - 9.10 x 5.05 - 4.60			
<b>8 x 6</b>	<b>1003-86*</b> 9.90 - 9.10 x 7.40 - 6.70	<b>1003-86RC*</b> 9.85 - 9.20 x 7.40 - 6.70		
<b>8 x 6 WC</b>	<b>1003-86WC*</b> 10.15 - 9.35 x 7.50 - 6.70	<b>1003-86WCRC*</b> 10.20 - 9.55 x 7.25 - 6.85		
<b>8 x 8</b>	<b>1003-88</b> 9.75 - 9.10 x 9.25 - 8.60	<b>1003-88RC</b> 9.80 - 9.05 x 9.20 - 8.50	<b>5003-88RC</b> 9.60 - 9.13 x 9.05 - 8.58	
<b>8 x 8 WC</b>	<b>1003-88WC*</b> 10.20 - 9.55 x 9.15 - 8.35	<b>1003-88WCRC*</b> 10.20 - 9.55 x 9.15 - 8.35		
<b>10 x 8</b>	<b>1003-10-8*</b> 12.70 - 12.00 x 9.15 - 8.60	<b>1003-10-8RC*</b> 12.70 - 12.00 x 9.20 - 8.85		<b>1003-10-8EB*</b> 12.70 - 12.00 x 9.20 - 8.85
<b>10 x 10</b>	<b>1003-1010*</b> 12.70 - 12.00 x 11.30 - 10.45	<b>1003-1010RC*</b> 12.70 - 12.00 x 11.30 - 10.45	<b>5003-1010RC*</b> 12.50 - 12.03 x 11.10 - 10.63	
<b>10 x 10 WC</b>	<b>1003-1010WC*</b> 12.70 - 12.00 x 11.30 - 10.45	<b>1003-1010WCRC*</b> 12.70 - 12.00 x 11.30 - 10.45	<b>5003-1010WCRC*</b> 12.50 - 12.03 x 11.10 - 10.63	
<b>12 x 10</b>	<b>1003-1210*</b> 14.70 - 13.75 x 11.30 - 10.45	<b>1003-1210RC*</b> 14.70 - 13.75 x 11.30 - 10.45		
<b>12 x 12</b>	<b>1003-1212</b> 15.00 - 14.00 x 13.50 - 12.60	<b>1003-1212RC*</b> 14.70 - 13.75 x 13.40 - 12.50	<b>5003-1212RC*</b> 14.50 - 14.03 x 13.20 - 12.73	

Resources



# CLAY TO ASBESTOS CEMENT OR DUCTILE IRON

**Red** high torque clamps included

\* Insert bushing included

<b>12 x 12 WC</b>	<b>1003-1212WC*</b> 15.45 - 14.50 x 13.50 - 12.50	<b>1003-1212WCRC*</b> 15.45 - 14.50 x 13.50 - 12.50	
<b>15 x 10</b>	<b>1003-1510*</b> 18.30 - 17.00 x 11.25 - 10.60	<b>1003-1510RC*</b> 18.65 - 17.00 x 11.30 - 10.85	<b>1003-1510EB*</b> 18.65 - 17.00 x 11.30 - 10.85
<b>15 x 12</b>	<b>1003-1512*</b> 18.30 - 17.00 x 13.50 - 12.50	<b>1003-1512RC*</b> 18.65 - 17.00 x 13.40 - 13.00	<b>1003-1512EB*</b> 18.65 - 17.00 x 13.40 - 13.00
<b>15 x 15</b>	<b>1003-1515*</b> 18.65 - 17.00 x 16.75 - 16.10	<b>1003-1515RC*</b> 18.65 - 17.00 x 16.75 - 16.10	
<b>15 x 16</b>	<b>1003-1516</b> 18.65 - 17.15 x 18.65 - 17.15	<b>1003-1516RC</b> 18.65 - 17.15 x 18.65 - 17.15	<b>5003-1516RC</b> 17.50 - 17.03 x 17.50 - 17.03
<b>18 x 18</b>	<b>1003-1818*</b> 22.50 - 20.85 x 20.00 - 18.50	<b>1003-1818RC*</b> 22.50 - 20.85 x 20.00 - 18.50	
<b>24 x 24</b>	<b>1003-2424*</b> 29.75 - 27.50 x 26.30 - 24.80	<b>1003-2424RC*</b> 29.75 - 27.50 x 26.30 - 24.80	

# CONCRETE TO CONCRETE

NOMINAL PIPE SIZE (INCHES)	STANDARD RANGE "A" x "B"	1000 RC SERIES RANGE "A" x "B"	5000 RC SERIES RANGE "A" x "B"	ECCENTRIC RANGE "A" x "B"
<b>4 x 4</b>	<b>1004-44</b> 5.85 - 5.15 x 5.85 - 5.15	<b>1004-44RC</b> 5.85 - 5.15 x 5.85 - 5.15	<b>5004-44RC</b> 5.60 - 5.36 x 5.60 - 5.36	
<b>6 x 4</b>	<b>1004-64*</b> 8.00 - 7.30 x 5.80 - 5.10			
<b>6 x 6</b>	<b>1004-66</b> 7.90 - 7.30 x 7.90 - 7.30	<b>1004-66RC</b> 7.90 - 7.30 x 7.90 - 7.30	<b>5004-66RC</b> 7.65 - 7.18 x 7.65 - 7.18	
<b>8 x 6</b>	<b>1004-86*</b> 10.50 - 9.75 x 7.90 - 7.20			
<b>8 x 8</b>	<b>1004-88</b> 10.65 - 9.90 x 10.65 - 9.90	<b>1004-88RC</b> 10.65 - 9.90 x 10.65 - 9.90	<b>5004-88RC</b> 10.40 - 9.93 x 10.40 - 9.93	
<b>10 x 8</b>	<b>use 1056-1210</b>			
<b>10 x 10</b>	<b>use 1001-1010</b>			
<b>10 x 10</b>	<b>1004-1010LC</b> 14.50 - 13.00 x 14.50 - 13.00	<b>1004-1010RC</b> 12.70 - 12.00 x 12.70 - 12.00	<b>5004-1010RC</b> 12.50 - 12.03 x 12.50 - 12.03	
<b>10 x 10</b>	<b>1004-1010LCRC</b> 14.50 - 13.00 x 14.50 - 13.00			
<b>12 x 10</b>	<b>1004-1210*</b> 15.45 - 14.50 x 12.65 - 11.70			<b>1004-1210EB*</b> 15.45 - 14.50 x 12.65 - 11.70
<b>12 x 12</b>	<b>1004-1212</b> 15.45 - 14.50 x 15.45 - 14.50	<b>1004-1212RC</b> 15.45 - 14.50 x 15.45 - 14.50	<b>5004-1212RC</b> 15.25 - 14.78 x 15.25 - 14.78	
<b>12 x 12 LC</b>	<b>1004-1212LC</b> 16.00 - 15.10 x 16.00 - 15.10	<b>1004-1212LCRC</b> 16.00 - 15.10 x 16.00 - 15.10	<b>5004-1212LCRC</b> 15.80 - 15.33 x 15.80 - 15.33	
<b>15 x 15</b>	<b>1004-1515</b> 20.20 - 18.90 x 20.20 - 18.90	<b>1004-1515RC</b> 20.20 - 18.90 x 20.20 - 18.90		
<b>18 x 18</b>	<b>1004-1818</b> 22.50 - 21.00 x 22.50 - 21.00	<b>1004-1818RC</b> 22.50 - 21.00 x 22.50 - 21.00		
<b>21 x 21</b>	<b>1004-2121</b> 26.60 - 25.10 x 26.60 - 25.10	<b>1004-2121RC</b> 26.60 - 25.10 x 26.60 - 25.10		
<b>24 x 24</b>	<b>1004-2424</b> 30.50 - 29.00 x 30.50 - 29.00	<b>1004-2424RC</b> 30.50 - 29.00 x 30.50 - 29.00		
<b>27 x 27</b>	<b>1004-2727</b> 33.90 - 32.00 x 33.90 - 32.00	<b>1004-2727RC</b> 33.90 - 32.00 x 33.90 - 32.00		

NOMINAL PIPE SIZE (INCHES)	STANDARD RANGE "A" x "B"	1000 RC SERIES RANGE "A" x "B"	5000 RC SERIES RANGE "A" x "B"	ECCENTRIC RANGE "A" x "B"
4 x 4	<b>1005-44*</b> 5.85 - 5.15 x 5.15 - 4.50	<b>1005-44RC*</b> 5.85 - 5.15 x 5.15 - 4.50		
6 x 4	<b>1005-64*</b> 7.90 - 7.30 x 5.10 - 4.65			<b>1005-64EB*</b> 7.90 - 7.30 x 5.10 - 4.65
6 x 6	<b>1005-66*</b> 7.90 - 7.30 x 7.35 - 6.75			
8 x 6	<b>1005-86*</b> 10.65 - 9.90 x 7.25 - 6.85			
8 x 8	<b>1005-88*</b> 10.65 - 9.90 x 9.80 - 9.15	<b>1005-88RC*</b> 10.65 - 9.90 x 9.80 - 9.15		
10 x 10	<b>use 1001-1010</b>			
12 x 10	<b>1005-1210*</b> 15.45 - 14.50 x 12.65 - 11.70			<b>1005-1210EB*</b> 15.45 - 14.50 x 12.65 - 11.70
12 x 12	<b>1005-1212*</b> 15.45 - 14.50 x 14.50 - 13.60			
15 x 15	<b>1005-1515*</b> 20.20 - 18.90 x 17.55 - 17.30	<b>1005-1515RC*</b> 20.20 - 18.90 x 17.55 - 17.30		

1006 & 5006 Series Couplings

CONCRETE TO CAST IRON, PLASTIC, OR STEEL

NOMINAL PIPE SIZE (INCHES)	STANDARD RANGE "A" x "B"	1000 RC SERIES RANGE "A" x "B"	5000 RC SERIES RANGE "A" x "B"	ECCENTRIC RANGE "A" x "B"
4 x 4	<b>1006-44</b> 5.75 - 5.25 x 4.50 - 4.00	<b>1006-44RC</b> 5.80 - 5.25 x 4.60 - 4.30	<b>5006-44RC</b> 5.90 - 5.66 x 4.50 - 4.26	<b>1006-44EB*</b> 5.85 - 5.40 x 4.60 - 4.05
4 x 4 SDR			<b>5006-44SDRRC*</b> 5.90 - 5.66 x 4.35 - 4.11	
4 x 4 LC	<b>1006-44LC</b> 6.10 - 5.60 x 4.70 - 4.20	<b>1006-44LCRC</b> 6.10 - 5.60 x 4.70 - 4.20	<b>5006-44LCRC</b> 5.90 - 5.43 x 4.50 - 4.03	
5 x 4	<b>use 1051-54</b>			
6 x 4	<b>1006-64</b> 7.95 - 7.25 x 4.50 - 4.00	<b>1006-64RC*</b> 7.90 - 7.30 x 4.60 - 4.15	<b>5006-64RC*</b> 7.65 - 7.18 x 4.50 - 4.03	<b>1006-64EB*</b> 7.90 - 7.30 x 4.60 - 4.15
6 x 4			<b>5006-64SDRRC*</b> 7.50 - 7.03 x 4.35 - 3.88	
6 x 5	<b>1006-65*</b> 8.00 - 7.30 x 5.60 - 5.10			<b>1006-65EB*</b> 7.90 - 7.30 x 5.80 - 5.20
6 x 6	<b>1006-66</b> 8.00 - 7.30 x 6.70 - 6.00	<b>1006-66RC</b> 7.65 - 7.05 x 6.60 - 6.40	<b>5006-66RC</b> 7.55 - 7.08 x 6.50 - 6.03	<b>1006-66EB*</b> 7.90 - 7.30 x 6.75 - 6.50
6 x 6 LC		<b>1006-66LCRC</b> 7.90 - 7.30 x 6.55 - 6.30	<b>5006-66LCRC</b> 8.00 - 7.53 x 6.65 - 6.18	
8 x 4	<b>1006-84*</b> 10.50 - 9.75 x 4.60 - 4.15			<b>1006-84EB*</b> 10.65 - 9.90 x 4.55 - 4.40
8 x 6	<b>1006-86*</b> 10.50 - 9.75 x 6.75 - 6.50	<b>1006-86RC*</b> 10.65 - 9.90 x 6.75 - 6.50	<b>5006-86RC*</b> 10.40 - 9.93 x 6.25 - 5.78	<b>1006-86EB*</b> 10.65 - 9.90 x 6.75 - 6.50
8 x 8	<b>1006-88</b> 10.50 - 9.75 x 8.70 - 7.95	<b>1006-88RC</b> 10.75 - 9.90 x 8.75 - 8.50	<b>5006-88RC</b> 10.50 - 10.03 x 8.65 - 8.18	<b>1006-88EB*</b> 10.65 - 9.90 x 8.85 - 8.30
8 x 8 LC	<b>1006-88LC*</b> 12.75 - 11.85 x 8.85 - 8.30			
10 x 8	<b>1006-10-8*</b> 12.75 - 11.85 x 8.85 - 8.30			<b>1006-10-8EB*</b> 12.70 - 12.00 x 8.85 - 8.30

Resources

<b>10 x 10</b>	<b>1006-1010</b> 12.85 - 12.00 x 10.75 - 9.85	<b>1006-1010RC*</b> 12.70 - 12.00 x 11.00 - 10.25	<b>5006-1010RC*</b> 12.50 - 12.03 x 10.75 - 10.28	
<b>10 x 10 LC</b>	<b>1006-1010LC*</b> 14.50 - 13.53 x 10.75 - 10.13	<b>1006-1010LCRC*</b> 14.50 - 13.53 x 10.75 - 10.13	<b>5006-1010LCRC*</b> 14.00 - 13.53 x 10.60 - 10.13	
<b>12 x 10</b>	<b>1006-1210*</b> 16.50 - 15.50 x 11.00 - 10.25	<b>1006-1210RC*</b> 15.45 - 14.50 x 10.75 - 10.30	<b>5006-1210RC*</b> 15.25 - 14.78 x 10.60 - 10.13	<b>1006-1210EB*</b> 15.45 - 14.50 x 10.75 - 10.10
<b>12 x 10</b>	<b>1006-1210LC*</b> 16.00 - 15.10 x 10.75 - 10.30			
<b>12 x 12</b>	<b>1006-1212</b> 16.50 - 15.50 x 12.60 - 11.75	<b>1006-1212RC*</b> 15.45 - 14.50 x 12.65 - 11.70	<b>5006-1212RC*</b> 15.25 - 14.78 x 12.35 - 11.88	<b>1006-1212EB*</b> 15.45 - 14.50 x 12.65 - 11.70
<b>12 x 12 LC</b>	<b>1006-1212LC*</b> 16.00 - 15.10 x 12.65 - 12.25	<b>1006-1212LCRC*</b> 16.00 - 15.10 x 12.65 - 12.25	<b>5006-1212LCRC*</b> 15.80 - 15.33 x 12.45 - 11.98	<b>1006-1212LCEB*</b> 16.00 - 15.10 x 12.65 - 12.25
<b>15 x 10</b>	<b>1006-1510*</b> 20.25 - 18.75 x 10.75 - 10.10	<b>1006-1510RC*</b> 20.20 - 18.90 x 10.75 - 10.30		
<b>15 x 12</b>	<b>1006-1512*</b> 20.25 - 18.75 x 12.65 - 11.70	<b>1006-1512RC*</b> 20.20 - 18.90 x 12.65 - 12.25		<b>1006-1512EB*</b> 20.20 - 18.90 x 12.65 - 12.25
<b>15 x 15</b>	<b>1006-1515</b> 20.25 - 18.75 x 16.00 - 14.75	<b>1006-1515RC</b> 20.20 - 18.90 x 15.40 - 15.15	<b>5006-1515RC*</b> 19.70 - 19.23 x 15.25 - 14.78	
<b>18 x 18</b>	<b>1006-1818*</b> 22.50 - 21.00 x 20.00 - 18.50	<b>1006-1818RC*</b> 22.50 - 21.00 x 20.00 - 18.50	<b>5006-1818RC*</b> 22.00 - 21.53 x 19.50 - 19.03	
<b>21 x 21</b>	<b>1006-2121*</b> 26.60 - 25.10 x 22.50 - 21.80	<b>1006-2121RC*</b> 26.60 - 25.10 x 22.50 - 21.80		
<b>24 x 24</b>	<b>1006-2424*</b> 30.50 - 29.00 x 25.50 - 24.00	<b>1006-2424RC*</b> 30.50 - 29.00 x 25.50 - 24.00		
<b>27 x 27</b>	<b>1006-2727*</b> 33.90 - 32.00 x 28.25 - 27.50	<b>1006-2727RC*</b> 33.90 - 32.00 x 28.25 - 27.50		

1051 & 5051 Series Couplings

**AC, DI TO CI, PLASTIC, OR STEEL**

NOMINAL PIPE SIZE (INCHES)	STANDARD RANGE "A" x "B"	1000 RC SERIES RANGE "A" x "B"	5000 RC SERIES RANGE "A" x "B"	ECCENTRIC RANGE "A" x "B"
<b>4 x 4</b>	<b>1051-44</b> 5.00 - 4.35 x 4.60 - 4.00	<b>1051-44RC</b> 5.00 - 4.40 x 4.50 - 4.00	<b>5051-44RC</b> 4.85 - 4.61 x 4.40 - 4.16	<b>1051-44EB*</b> 4.90 - 4.50 x 4.50 - 4.00
<b>4 x 5</b>	<b>1051-45*</b> 5.15 - 4.50 x 5.70 - 5.20	<b>1051-45RC*</b> 5.15 - 4.50 x 5.70 - 5.20		
<b>4 x 6</b>	<b>1051-46*</b> 4.90 - 4.30 x 6.80 - 6.30	<b>1051-46RC*</b> 4.90 - 4.30 x 6.80 - 6.30	<b>5051-46RC*</b> 6.65 - 6.18 x 4.75 - 4.28	<b>1051-46EB*</b> 5.05 - 4.75 x 6.80 - 6.30
<b>5 x 4</b>	<b>1051-54</b> 5.95 - 5.25 x 4.75 - 4.00			<b>1051-54EB*</b> 6.15 - 5.50 x 4.55 - 3.95
<b>5 x 5</b>	<b>1051-55*</b> 6.30 - 5.60 x 5.70 - 5.25	<b>1051-55RC*</b> 6.15 - 5.50 x 5.50 - 5.20		
<b>6 x 4</b>	<b>1051-64*</b> 7.10 - 6.45 x 4.50 - 4.00	<b>1051-64RC*</b> 7.10 - 6.35 x 4.60 - 4.15	<b>5051-64RC*</b> 6.95 - 6.48 x 4.60 - 4.15	<b>1051-64EB*</b> 6.80 - 6.30 x 4.60 - 4.15
<b>6 x 5</b>	<b>1051-65*</b> 7.00 - 6.35 x 5.35 - 4.70	<b>1051-65RC*</b> 7.10 - 6.35 x 5.70 - 5.20		<b>1051-65EB*</b> 6.80 - 6.30 x 5.70 - 5.20
<b>6 x 6</b>	<b>1051-66</b> 7.00 - 6.35 x 6.60 - 6.00	<b>1051-66RC</b> 7.20 - 6.50 x 6.90 - 6.20	<b>5051-66RC</b> 7.00 - 6.53 x 6.70 - 6.23	
<b>8 x 4</b>	<b>1051-84*</b> 9.25 - 8.60 x 4.60 - 4.15	<b>1051-84RC*</b> 9.25 - 8.55 x 4.70 - 4.40	<b>5051-84RC*</b> 9.05 - 8.58 x 4.55 - 4.08	<b>1051-84EB*</b> 9.25 - 8.80 x 4.60 - 4.15
<b>8 x 6</b>	<b>1051-86*</b> 9.25 - 8.60 x 6.75 - 6.50	<b>1051-86RC*</b> 9.25 - 8.55 x 6.75 - 6.50		<b>1051-86EB*</b> 9.25 - 8.55 x 6.75 - 6.50
<b>8 x 8</b>	<b>1051-88</b> 9.25 - 8.60 x 8.70 - 8.00	<b>1051-88RC</b> 9.40 - 8.75 x 8.65 - 7.95	<b>5051-88RC</b> 9.25 - 8.78 x 8.45 - 7.98	
<b>10 x 8</b>	<b>1051-10-8*</b> 11.15 - 10.25 x 8.85 - 8.30	<b>1051-10-8RC*</b> 10.95 - 10.05 x 8.85 - 8.30		
<b>10 x 10</b>	<b>1051-1010</b> 11.15 - 10.25 x 10.75 - 9.90	<b>1051-1010RC</b> 10.95 - 10.05 x 10.70 - 9.80	<b>5051-1010RC</b> 10.75 - 10.28 x 10.50 - 10.03	
<b>12 x 10</b>	<b>1051-1210*</b> 13.20 - 12.25 x 11.00 - 10.25	<b>1051-1210RC*</b> 13.30 - 12.55 x 10.85 - 10.15		<b>1051-1210EB*</b> 13.30 - 12.55 x 10.85 - 10.15



<b>12 x 12</b>	<b>1051-1212</b> 13.20 - 12.25 x 12.60 - 11.75	<b>1051-1212RC*</b> 13.30 - 12.55 x 12.70 - 11.60	<b>5051-1212RC*</b> 13.05 - 12.58 x 12.35 - 11.88	
<b>12 x 15</b>	<b>1051-1215*</b> 13.50 - 12.50 x 15.75 - 14.50	<b>1051-1215RC*</b> 13.50 - 12.50 x 15.75 - 14.50	<b>5051-1215RC*</b> 13.20 - 12.73 x 15.40 - 14.93	
<b>15 x 10</b>	<b>1051-1510*</b> 16.00 - 14.90 x 10.75 - 10.30			<b>1051-1510EB*</b> 16.00 - 14.90 x 10.75 - 10.30
<b>15 x 12</b>	<b>1051-1512*</b> 16.00 - 14.90 x 12.65 - 12.25			
<b>15 x 15</b>	<b>1051-1515</b> 16.00 - 14.90 x 16.00 - 14.90	<b>1051-1515RC*</b> 16.00 - 14.90 x 16.00 - 14.90		
<b>18 x 18</b>	<b>1051-1818*</b> 20.10 - 19.00 x 19.00 - 18.00	<b>1051-1818RC*</b> 20.10 - 19.00 x 19.00 - 18.00		
<b>24 x 24</b>	<b>1051-2424*</b> 26.30 - 24.30 x 25.30 - 23.30	<b>1051-2424RC*</b> 26.30 - 24.30 x 25.30 - 23.30		

NOMINAL PIPE SIZE (INCHES)	STANDARD RANGE "A" x "B"	1000 RC SERIES RANGE "A" x "B"	5000 RC SERIES RANGE "A" x "B"	ECCENTRIC RANGE "A" x "B"
<b>4 x 4</b>	<b>1055-44</b> 4.90 - 4.50 x 4.90 - 4.50	<b>1055-44RC</b> 4.90 - 4.50 x 4.90 - 4.50	<b>5055-44RC</b> 4.75 - 4.28 x 4.75 - 4.28	
<b>5 x 4</b>	<b>1055-54*</b> 6.30 - 5.60 x 5.15 - 4.50			
<b>5 x 5</b>	<b>1055-55</b> 6.20 - 5.40 x 6.05 - 5.35			
<b>6 x 4</b>	<b>1055-64</b> 7.00 - 6.15 x 4.90 - 4.30	<b>1055-64RC*</b> 7.10 - 6.35 x 5.10 - 4.80		<b>1055-64EB*</b> 7.10 - 6.35 x 5.10 - 4.80
<b>6 x 5</b>	<b>1055-65</b> 6.95 - 6.20 x 5.90 - 5.30			<b>1055-65EB*</b> 7.10 - 6.35 x 6.10 - 5.60
<b>6 x 6</b>	<b>1055-66</b> 7.10 - 6.35 x 7.10 - 6.35	<b>1055-66RC</b> 7.10 - 6.35 x 7.10 - 6.35	<b>5055-66RC</b> 6.95 - 6.48 x 6.95 - 6.48	
<b>8 x 4</b>	<b>1055-84*</b> 9.25 - 8.60 x 5.05 - 4.60			<b>1055-84EB*</b> 9.25 - 8.55 x 5.15 - 4.75
<b>8 x 6</b>	<b>1055-86*</b> 9.25 - 8.60 x 6.90 - 6.25	<b>1055-86RC*</b> 9.25 - 8.55 x 6.85 - 6.50	<b>5055-86RC*</b> 9.10 - 8.63 x 6.70 - 6.23	<b>1055-86EB*</b> 9.25 - 8.55 x 6.85 - 6.50
<b>8 x 8</b>	<b>1055-88</b> 9.25 - 8.55 x 9.25 - 8.55	<b>1055-88RC</b> 9.25 - 8.55 x 9.25 - 8.55	<b>5055-88RC</b> 9.05 - 8.58 x 9.05 - 8.58	
<b>10 x 8</b>	<b>1055-10-8*</b> 11.15 - 10.25 x 9.15 - 8.60			<b>1055-10-8EB*</b> 10.95 - 10.25 x 9.15 - 8.60
<b>10 x 10</b>	<b>1055-1010</b> 10.95 - 10.25 x 10.95 - 10.25	<b>1055-1010RC</b> 10.95 - 10.25 x 10.95 - 10.25	<b>5055-1010RC</b> 10.75 - 10.28 x 10.75 - 10.28	
<b>12 x 8</b>	<b>1055-12-8*</b> 13.20 - 12.25 x 9.20 - 8.85			
<b>12 x 10</b>	<b>1055-1210*</b> 13.20 - 12.25 x 11.30 - 10.45	<b>1055-1210RC*</b> 13.30 - 12.55 x 11.35 - 10.65		<b>1055-1210EB*</b> 13.30 - 12.55 x 11.35 - 10.65
<b>12 x 12</b>	<b>1055-1212</b> 13.30 - 12.55 x 13.30 - 12.55	<b>1055-1212RC</b> 13.30 - 12.55 x 13.30 - 12.55	<b>5055-1212RC</b> 13.05 - 12.58 x 13.05 - 12.58	
<b>15 x 10</b>	<b>1055-1510*</b> 16.60 - 15.35 x 11.30 - 10.85			
<b>15 x 12</b>	<b>1055-1512*</b> 16.60 - 15.35 x 13.25 - 12.70	<b>1055-1512RC*</b> 16.60 - 15.35 x 13.40 - 13.00		<b>1055-1512EB*</b> 16.60 - 15.35 x 13.40 - 13.00
<b>15 x 15</b>	<b>1055-1515</b> 16.60 - 15.35 x 16.60 - 15.35	<b>1055-1515RC</b> 16.60 - 15.35 x 16.60 - 15.35		
<b>18 x 18</b>	<b>1055-1818</b> 19.60 - 18.10 x 19.60 - 18.10	<b>1055-1818RC</b> 19.60 - 18.10 x 19.60 - 18.10		
<b>24 x 24</b>	<b>1055-2424</b> 26.30 - 24.30 x 26.30 - 24.30	<b>1055-2424RC</b> 26.30 - 24.30 x 26.30 - 24.30		

Resources

NOMINAL PIPE SIZE (INCHES)	STANDARD RANGE "A" x "B"	1000 RC SERIES RANGE "A" x "B"	5000 RC SERIES RANGE "A" x "B"	ECCENTRIC RANGE "A" x "B"
0.75 x 0.75	<b>1056-075</b> 1.10 - 0.80 x 1.10 - 0.80			
1 x 1	<b>1056-100</b> 1.35 - 1.05 x 1.35 - 1.05			
1.25 x 1.25	<b>1056-125</b> 1.70 - 1.40 x 1.70 - 1.40			
1.50 x 1.25	<b>1056-150/125</b> 2.05 - 1.70 x 1.70 - 1.40			
1.50 x 1.50	<b>1056-150</b> 2.00 - 1.65 x 2.00 - 1.65	<b>1056-150RC</b> 2.00 - 1.65 x 2.00 - 1.65		
2 x 1.50	<b>1056-215</b> 2.50 - 2.15 x 1.95 - 1.70	<b>1056-215RC*</b> 2.50 - 2.15 x 1.95 - 1.80		
2 x 2	<b>1056-22</b> 2.50 - 2.15 x 2.50 - 2.15	<b>1056-22RC</b> 2.50 - 2.15 x 2.50 - 2.15		
2.50 x 1.25	<b>1056-250/125</b> 3.10 - 2.50 x 1.75 - 1.40	<b>1056-250/125RC*</b> 3.10 - 2.50 x 1.75 - 1.40		
2.50 x 1.50	<b>1056-250/150</b> 3.10 - 2.50 x 2.00 - 1.65	<b>1056-250/150RC*</b> 3.10 - 2.50 x 2.00 - 1.65		
2.50 x 2	<b>1056-250/22</b> 3.00 - 2.70 x 2.50 - 2.25	<b>1056-250/22RC*</b> 3.00 - 2.70 x 2.50 - 2.25		
2.50 x 2.50	<b>1056-250</b> 3.10 - 2.50 x 3.10 - 2.50	<b>1056-250RC</b> 3.00 - 2.70 x 3.00 - 2.70		
3 x 1.50	<b>1056-315</b> 3.50 - 3.15 x 1.95 - 1.65			<b>1056-315EB*</b> 3.70 - 3.15 x 1.95 - 1.80
3 x 2	<b>1056-32</b> 3.65 - 3.15 x 2.50 - 2.20	<b>1056-32RC*</b> 3.70 - 3.15 x 2.50 - 2.25		<b>1056-32EB*</b> 3.70 - 3.15 x 2.50 - 2.25
3 x 2.50	<b>1056-3/250*</b> 3.70 - 3.15 x 3.00 - 2.75	<b>1056-3/250RC*</b> 3.70 - 3.15 x 3.00 - 2.75		
3 x 3	<b>1056-33</b> 3.70 - 3.15 x 3.70 - 3.10	<b>1056-33RC</b> 3.70 - 3.15 x 3.70 - 3.10	<b>5056-33RC</b> 3.50 - 3.26 x 3.50 - 3.26	
4 x 1.50	<b>1056-415</b> 4.50 - 4.00 x 1.95 - 1.75			
4 x 2	<b>1056-42</b> 4.50 - 4.00 x 2.50 - 2.25	<b>1056-42RC*</b> 4.60 - 4.10 x 2.50 - 2.30		<b>1056-42EB*</b> 4.60 - 4.10 x 2.50 - 2.30
4 x 3	<b>1056-43</b> 4.65 - 4.25 x 3.65 - 3.25	<b>1056-43RC*</b> 4.65 - 4.25 x 3.50 - 3.30	<b>5056-43RC*</b> 4.50 - 4.26 x 3.50 - 3.26	<b>1056-43EB*</b> 4.65 - 4.25 x 3.50 - 3.30
4 x 4	<b>1056-44</b> 4.65 - 4.10 x 4.65 - 4.10	<b>1056-44RC</b> 4.65 - 4.10 x 4.65 - 4.10	<b>5056-44RC</b> 4.50 - 4.26 x 4.50 - 4.26	
5 x 4	<b>1056-54</b> 5.65 - 5.25 x 4.50 - 4.00	<b>1056-54RC*</b> 5.70 - 5.10 x 4.55 - 3.95	<b>5056-54RC*</b> 5.50 - 5.03 x 4.40 - 3.93	<b>1056-54EB*</b> 5.70 - 5.10 x 4.60 - 4.05
5 x 5	<b>1056-55</b> 5.70 - 5.10 x 5.70 - 5.10	<b>1056-55RC</b> 5.70 - 5.10 x 5.70 - 5.10		
6 x 4	<b>1056-64</b> 6.85 - 6.25 x 4.60 - 4.10	<b>1056-64RC*</b> 6.85 - 6.25 x 4.55 - 4.40	<b>5056-64RC*</b> 6.65 - 6.18 x 4.50 - 4.03	<b>1056-64EB*</b> 6.80 - 6.30 x 4.60 - 4.15
6 x 5	<b>1056-65</b> 6.65 - 6.10 x 5.65 - 5.15	<b>1056-65RC*</b> 6.80 - 6.30 x 5.70 - 5.10	<b>5056-65RC*</b> 6.65 - 6.18 x 5.50 - 5.03	<b>1056-65EB*</b> 6.80 - 6.30 x 5.70 - 5.10
6 x 6	<b>1056-66</b> 6.80 - 6.30 x 6.80 - 6.30	<b>1056-66RC</b> 6.80 - 6.30 x 6.80 - 6.30	<b>5056-66RC</b> 6.65 - 6.18 x 6.65 - 6.18	
8 x 4	<b>1056-84*</b> 8.60 - 8.05 x 4.55 - 4.20	<b>1056-84RC*</b> 8.75 - 8.00 x 4.65 - 4.25		<b>1056-84EB*</b> 8.75 - 8.00 x 4.65 - 4.25
8 x 6	<b>1056-86</b> 8.60 - 8.05 x 6.50 - 6.10	<b>1056-86RC*</b> 8.75 - 8.00 x 6.75 - 6.50	<b>5056-86RC*</b> 8.65 - 8.18 x 6.35 - 5.88	<b>1056-86EB*</b> 8.75 - 8.00 x 6.75 - 6.50
8 x 8	<b>1056-88</b> 8.75 - 8.00 x 8.75 - 8.00	<b>1056-88RC</b> 8.75 - 8.00 x 8.75 - 8.00	<b>5056-88RC</b> 8.65 - 8.18 x 8.65 - 8.18	

<b>10 x 8</b>	<b>1056-10-8</b> 10.60 - 9.60 x 8.65 - 7.85	<b>1056-10-8RC*</b> 10.80 - 10.10 x 8.85 - 8.30	<b>5056-10-8RC*</b> 10.65 - 10.18 x 8.65 - 8.18	<b>1056-10-8EB*</b> 10.80 - 10.10 x 8.85 - 8.30
<b>10 x 10</b>	<b>1056-1010</b> 10.80 - 10.10 x 10.80 - 10.10	<b>1056-1010RC</b> 10.80 - 10.10 x 10.80 - 10.10	<b>5056-1010RC</b> 10.65 - 10.18 x 10.65 - 10.18	
<b>12 x 10</b>	<b>1056-1210</b> 12.75 - 11.85 x 10.80 - 10.00	<b>1056-1210RC*</b> 12.75 - 12.00 x 11.00 - 10.25	<b>5056-1210RC*</b> 12.55 - 12.08 x 10.75 - 10.28	<b>1056-1210EB*</b> 12.75 - 12.00 x 10.75 - 10.25
<b>12 x 12</b>	<b>1056-1212</b> 12.75 - 12.00 x 12.75 - 12.00	<b>1056-1212RC</b> 12.75 - 12.00 x 12.75 - 12.00	<b>5056-1212RC</b> 12.55 - 12.08 x 12.55 - 12.08	
<b>15 x 10</b>	<b>1056-1510*</b> 15.75 - 15.40 x 11.00 - 10.25			<b>1056-1510EB*</b> 15.75 - 14.50 x 10.75 - 10.10
<b>15 x 12</b>	<b>1056-1512*</b> 16.35 - 15.50 x 12.60 - 11.75	<b>1056-1512RC*</b> 15.75 - 14.50 x 12.65 - 11.70		<b>1056-1512EB*</b> 15.75 - 14.50 x 12.65 - 11.70
<b>15 x 15</b>	<b>1056-1515</b> 15.75 - 14.50 x 15.75 - 14.50	<b>1056-1515RC</b> 15.75 - 14.50 x 15.75 - 14.50	<b>5056-1515RC</b> 15.40 - 14.93 x 15.40 - 14.93	
<b>18 x 18</b>	<b>1056-1818</b> 19.00 - 17.50 x 19.00 - 17.50	<b>1056-1818RC</b> 19.00 - 17.50 x 19.00 - 17.50	<b>5056-1818RC</b> 18.50 - 18.03 x 18.50 - 18.03	
<b>21 x 21</b>	<b>1056-2121</b> 22.50 - 20.50 x 22.50 - 20.50	<b>1056-2121RC</b> 22.50 - 20.50 x 22.50 - 20.50		
<b>24 x 24</b>	<b>1056-2424</b> 25.00 - 23.00 x 25.00 - 23.00	<b>1056-2424RC</b> 25.00 - 23.00 x 25.00 - 23.00	<b>5056-2424RC</b> 24.50 - 24.03 x 24.50 - 24.03	
<b>27 x 27</b>	<b>1056-2727</b> 28.20 - 26.20 x 28.20 - 26.20	<b>1056-2727RC</b> 28.20 - 26.20 x 28.20 - 26.20		



NOMINAL PIPE SIZE (INCHES)	STANDARD RANGE "A" x "B"	1000 RC SERIES RANGE "A" x "B"	5000 RC SERIES RANGE "A" x "B"	ECCENTRIC RANGE "A" x "B"
4 x 4	<b>1057-44*</b> 5.85 - 5.15 x 5.15 - 4.50	<b>1057-44RC*</b> 5.85 - 5.15 x 5.15 - 4.50		
6 x 4	<b>1057-64*</b> 7.90 - 7.30 x 5.15 - 4.50			<b>1057-64EB*</b> 7.90 - 7.30 x 5.15 - 4.50
6 x 6	<b>1057-66*</b> 7.90 - 7.30 x 6.90 - 6.25	<b>1057-66RC*</b> 7.90 - 7.30 x 6.90 - 6.25		
6 x 8	<b>1057-68*</b> 9.25 - 8.55 x 7.85 - 7.20	<b>1057-68RC*</b> 9.25 - 8.55 x 7.85 - 7.20		<b>1057-68EBRC*</b> 9.25 - 8.55 x 7.85 - 7.20
8 x 6	<b>1057-86*</b> 10.20 - 9.50 x 6.90 - 6.25	<b>1057-86RC*</b> 10.65 - 9.90 x 6.90 - 6.25		
8 x 8	<b>1057-88</b> 10.20 - 9.50 x 9.00 - 8.45	<b>1057-88RC*</b> 10.65 - 9.90 x 9.15 - 8.60		
10 x 10	<b>1057-1010*</b> 12.70 - 12.00 x 11.30 - 10.45	<b>1057-1010RC*</b> 12.70 - 12.00 x 11.30 - 10.45		
10 x 10 LC			<b>5057-1010LCRC*</b> 14.00 - 13.53 x 11.10 - 10.63	
12 x 6	<b>1057-12-6*</b> 15.45 - 14.50 x 6.90 - 6.25			<b>1057-12-6EB*</b> 15.45 - 14.50 x 6.90 - 6.25
12 x 8	<b>1057-12-8*</b> 16.50 - 15.50 x 9.20 - 8.85			<b>1057-12-8EB*</b> 15.75 - 14.50 x 9.20 - 8.85
12 x 10	<b>1057-1210*</b> 16.50 - 15.50 x 11.30 - 10.45			
12 x 10 LC	<b>1057-1210LC*</b> 16.00 - 15.10 x 11.30 - 10.45			
12 x 12	<b>1057-1212*</b> 15.45 - 14.50 x 13.50 - 12.50	<b>1057-1212RC*</b> 15.45 - 14.50 x 13.50 - 12.50		
12 x 12 LC	<b>1057-1212LC*</b> 16.00 - 15.10 x 13.50 - 12.50	<b>1057-1212LCRC*</b> 16.00 - 15.10 x 13.50 - 12.50		
15 x 8	<b>1057-15-8*</b> 20.25 - 18.75 x 9.20 - 8.85			<b>1057-15-8EB*</b> 20.25 - 18.75 x 9.20 - 8.85
15 x 10	<b>1057-1510*</b> 20.25 - 18.75 x 11.30 - 10.45			
15 x 12	<b>1057-1512*</b> 20.25 - 18.75 x 13.50 - 12.50	<b>1057-1512RC*</b> 20.20 - 18.90 x 13.50 - 12.50		
15 x 15	<b>1057-1515*</b> 20.20 - 18.90 x 16.75 - 16.10	<b>1057-1515RC*</b> 20.20 - 18.90 x 16.75 - 16.10		
18 x 18	<b>1057-1818*</b> 22.50 - 21.00 x 19.80 - 19.35	<b>1057-1818RC*</b> 22.50 - 21.00 x 19.80 - 19.35		
24 x 24	<b>1057-2424*</b> 30.50 - 29.00 x 25.90 - 25.45	<b>1057-2424RC*</b> 30.50 - 29.00 x 25.90 - 25.45		

# Plumbing Market Sales Reps

**1. David Gooding, Inc.**

Brockton, MA  
(508) 894-2000  
ME, NH, VT, MA, RI, CT

**2. Empire State Assoc.**

Ballston Spa, NY  
(518) 602-0271  
NY

**3. Altherm, Inc.**

Englewood, NJ  
(201) 871-0500  
New York City, Long Island,  
Northern New Jersey

**4. Rich-Tomkins Company, Inc.**

Aston, PA  
(610) 859-3552  
E. PA, Southern NJ, DE

**5. Fehr & Cuda Sales, Inc.**

Greensburg, PA  
(724) 838-9394  
West PA & WV

**6. Lowder Sales**

Lewis Center, OH  
(800) 221-5650  
OH

**7. Lozuaway & Assoc.**

Grand Blanc, MI  
(810) 234-1635  
MI

**8. Ashworth—Train Assoc.**

Indianapolis, IN  
(317) 722-1950  
IN

**9. Kast Marketing, Inc.**

Bensonville, IL  
(630) 227-0600  
N. IL

**10. McCullough & Assoc.**

Edina, MN  
(952) 946-0126  
MN, WI, ND, SD, Upper MI

**11. I and N Marketing Group**

Earlham, IA  
(515) 758-2956  
IA, NE

**12. Mack McClain & Assoc.**

Olathe, KS  
(913) 339-6677  
KS, W. MO

**13. T.M. Sales**

Denver, CO  
(303) 375-1515  
CO, MT, WY

**14. McGregor & Assoc.**

West Jordan, UT  
(801) 566-8225  
UT, ID

**15. Gordon & Assoc.**

Vancouver, WA  
(360) 566-1470  
WA, OR, AK

**16. RD/Kincaide & Assoc.**

Benicia, CA  
(707) 745-3655  
N. CA & N. NV

**17. Carrhill Company**

City of Commerce, CA  
(323) 724-6087  
S. CA, Clark County, NV, HI

**18. New Horizon Sales, Inc.**

Phoenix, AZ  
(602) 437-4795  
AZ

**19. Stan Roberts & Assoc., Inc.**

Houston, TX  
(713) 224-9845  
South TX

Dallas, TX

(214) 637-2816  
North TX

**20. PSA**

Little Rock, AR  
(501) 312-8700  
AR

**21. OK! Sales**

Broken Arrow, OK  
(405) 794-5200  
Tulsa, OK

**22. Mack McClain**

St. Louis, MO  
(314) 894-8188  
S. IL, E. MO

**23. Billingsley BWC**

Kenner, LA  
(504) 602-8100  
LA, MS

**24. Wm. M. McClain Co, Inc.**

Nashville, TN  
(615) 226-9601  
TN

**25. Wiggs-Haun & Bohan**

Nashville, TN  
(615) 350-8334  
AL, Panhandle FL

**26. United Sales Agency**

Marietta, GA  
(770) 514-7444  
GA

**27. Carr Company**

Boca Raton, FL  
(561) 997-0999  
FL, except Panhandle

**28. Carolina Sales**

Charlotte, NC  
(803) 831-7227  
NC, SC

**29. Barger & Assoc.**

Yorktown, MD  
(888) 697-3755  
VA, D.C., MD

**30. Pinnacle Marketing**

Albuquerque, NM  
(502) 345-2700  
NM

**31. Kemper Sales & Assoc.**

Nicholasville, KY  
(859) 881-8624  
KY

## PUERTO RICO

**33. Inter American Builders**

**Agencies**  
Carolina, PR  
(787) 752-0200  
Puerto Rico

## MEXICO

**34. Ardent Sales**

Long Beach, CA  
(562) 552-4169  
Mexico

## CANADA

**40. Barclay Sales LTD.**

Port Coquitlam, BC  
(604) 945-1010

**41. Spectrum Sales Agencies 1982 LTD.**

Calgary, Alberta  
(403) 255-8332

Edmonton, Alberta  
(780) 486-2525

**42. Jones Goodridge**

Winnipeg, Manitoba  
(204) 632-6221

Regina, Sask  
(306) 530-9056

Saskatoon, Sask  
(306) 933-4377

**43. Showerline Sales LTD.**

London, Ontario  
(519) 657-2694

Waterloo, Ontario  
(519) 885-1578

**44. Armco Agencies LTD.**

Mississauga, Ontario  
(905) 238-8448

**45. Ventes Bergeron Sales**

Russell, Ontario  
(613) 445-4170

**46. Northern Mechanical Sales**

Garson, Ontario  
(705) 693-2715

**47. Agencies J. Pierre**

**Sylvain, Inc.**  
Boucherville, Que.  
(450) 655-9588

Quebec, PQ  
(418) 570-0703

**48. NerohTek Sales**

Windsor, N.S.  
(902) 869-0103

**49. Par Four Plumbing**

St. Johns, N.F.  
(709) 739-7177

# Plumbing Market Sales Reps

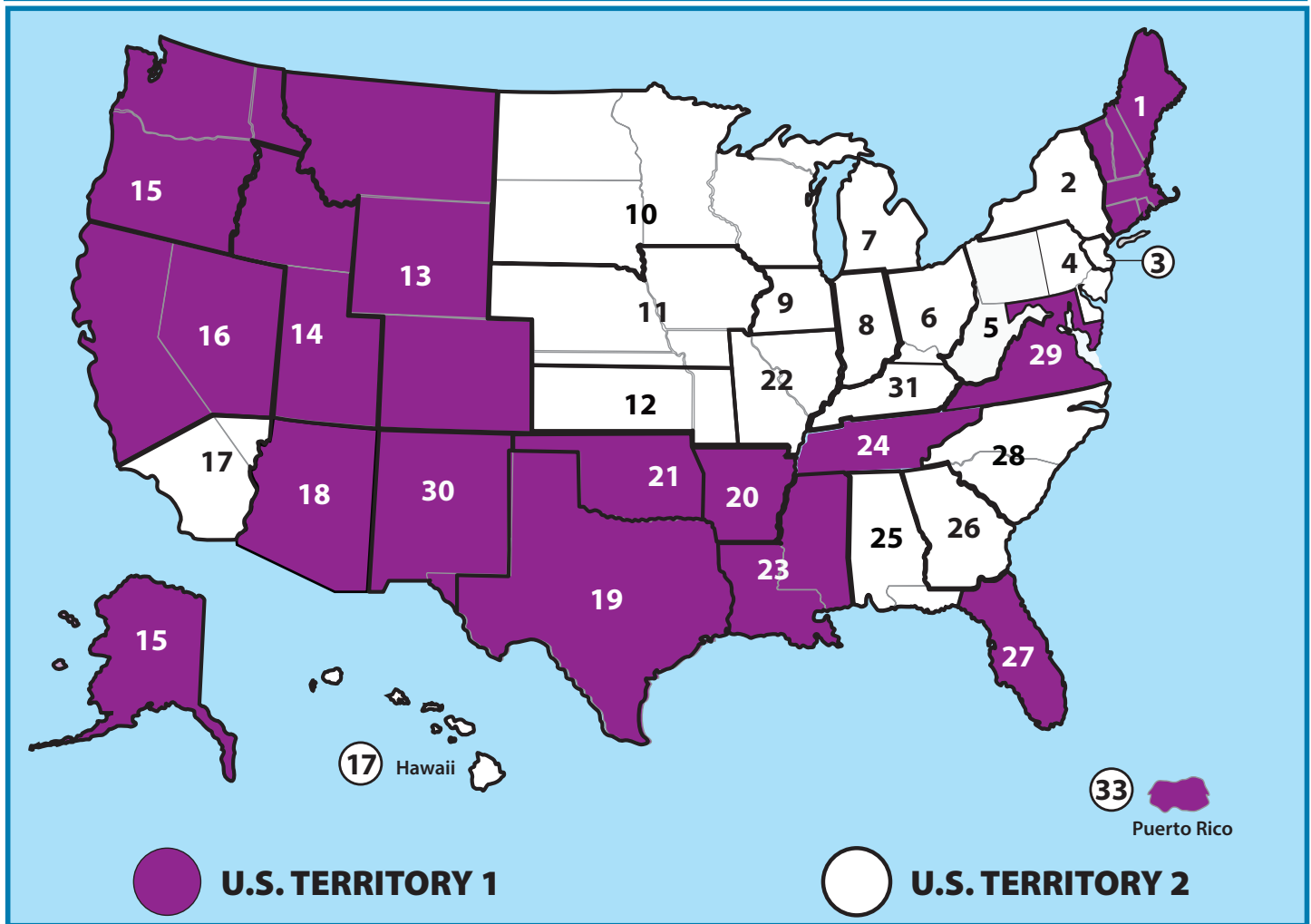
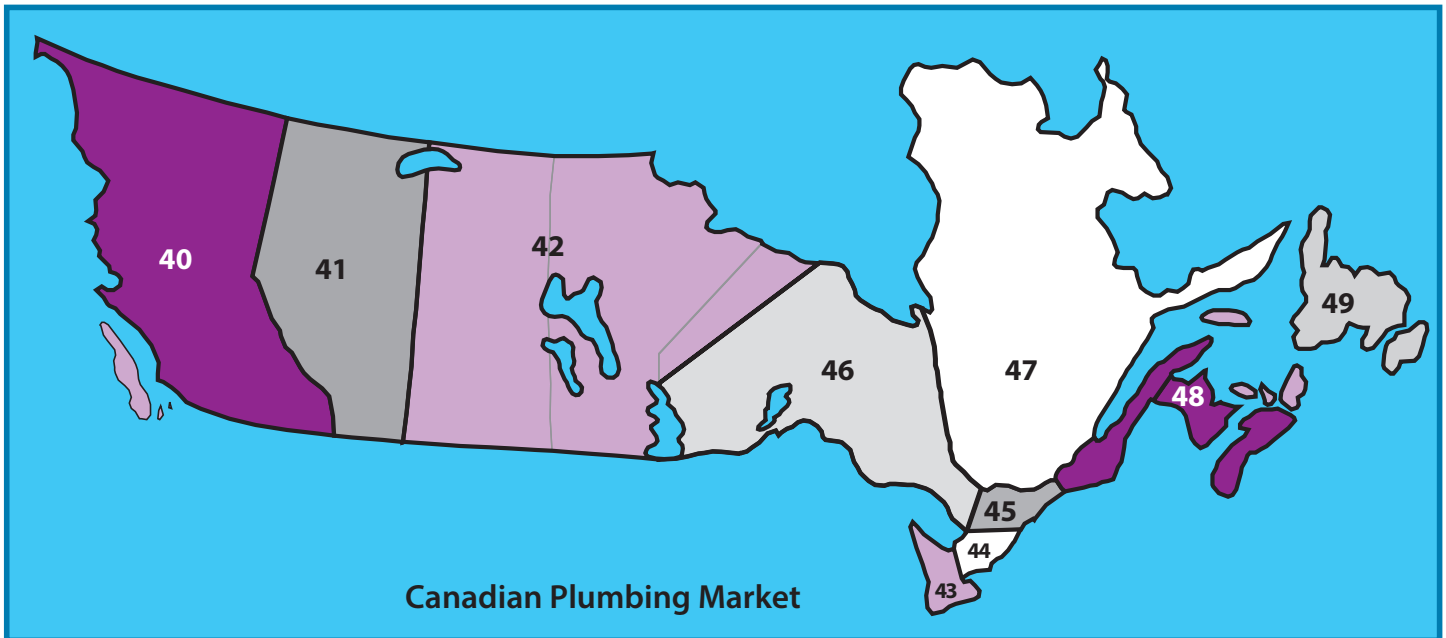

Resources



# WaterWorks Market Sales Map

## 1. David Gooding, Inc.

Brockton, MA  
(508) 894-2000  
ME, NH, VT, MA, RI, CT

## 2. Empire State Assoc.

Ballston Spa, NY  
(518) 602-0271  
NY

## 3. Saga Sales, Inc.

Englewood, NJ  
(908) 505-9990  
New York City, Long Island,  
Northern New Jersey

## 4. Charles Morrow & Assoc.

Buckhannon, WV  
(304) 472-9005  
E. PA, S. NJ, DE, VA, D.C., MD

## 5. Fehr & Cuda Sales, Inc.

Greensburg, PA  
(724) 838-9394  
West PA & WV

## 6. Hydrosource

Chagrin Falls, OH  
(440) 247-9150  
IN, OH, Lower MI

## 7. Eaton Mechanical Sales

Prarie View, IL  
(847) 980-7253  
N. IL

## 8. Mack McClain & Assoc.

Olathe, KS  
(913) 339-6677  
KS, W. MO  
St. Louis, MO  
(314) 894-8188  
S. IL, E. MO

## 9. I and N Marketing Group

Earlham, IA  
(515) 758-2956  
IA, NE

## 10. McCullough & Assoc.

Edina, MN  
(952) 946-0126  
MN, WI, ND, SD, Upper MI

## 11. Repmasters, Inc.

Commerce City, CO  
(303) 286-7575  
CO, MT, WY

## 12. McGregor & Assoc.

West Jordan, UT  
(801) 566-8225  
UT, ID

## 13. Gordon & Assoc.

Vancouver, WA  
(360) 566-1470  
WA, OR, AK, HI

## 14. RD/Kincaide & Assoc.

Benicia, CA  
(707) 745-3655  
N. CA & N. NV

## 15. Stan Roberts & Assoc., Inc.

Houston, TX  
(713) 224-9845  
South TX  
Dallas, TX  
(214) 637-2816  
North TX

## 16. PSA

Little Rock, AR  
(501) 312-8700  
AR

## 17. OK! Sales

Broken Arrow, OK  
(405) 794-5200  
OK

## 18. Billingsley BWC

Kenner, LA  
(504) 602-8100  
LA, MS

## 19. Wm. M. McClain Co, Inc.

Nashville, TN  
(615) 226-9601  
TN

## 20. Wiggs-Haun & Bohan

Nashville, TN  
(615) 350-8334  
AL

## 21. Diversified Infrastructure

Kennesaw, GA  
(770) 425-6028  
GA

## 22. L.J. Ruffin & Assoc.

Boca Raton, FL  
(561) 997-0999  
FL

## 23. Ultratech Water Resources

Shelby, NC  
(704) 445-0220  
NC, SC

## 24. Pinnacle Marketing

Albuquerque, NM  
(502) 345-2700  
NM, El Paso, TX

## 25. Kemper Sales & Assoc.

Nicholasville, KY  
(859) 881-8624  
KY

## 26. New Horizon Sales, Inc.

Phoenix, AZ  
(602) 437-4795  
Clark County, NV, AZ

## 27. W4 (Westcoast Water Works Warehouse)

Corona, CA  
(951) 279-4444  
S. CA

## 28. JT Sales Company

Temecula, CA  
(951) 501-6859  
S. CA

## PUERTO RICO

### 29. Inter American Builders Agencies

Carolina, PR  
(787) 752-0200  
Puerto Rico

## MEXICO

### 40. Ardent Sales

Long Beach, CA  
(562) 552-4169  
Mexico

## CANADA

### 30. Barclay Sales LTD.

Port Coquitlam, BC  
(604) 945-1010

### 31. Spectrum Sales Agencies 1982 LTD.

Calgary, Alberta  
(403) 255-8332  
Edmonton, Alberta  
(780) 486-2525

### 32. Jones Goodridge

Winnipeg, Manitoba  
(204) 632-6221  
Regina, Sask  
(306) 530-9056

Saskatoon, Sask  
(306) 933-4377

### 33. Showerline Sales LTD.

London, Ontario  
(519) 657-2694  
Waterloo, Ontario  
(519) 885-1578

### 34. Armco Agencies LTD.

Mississauga, Ontario  
(905) 238-8448

### 35. Ventes Bergeron Sales

Russell, Ontario  
(613) 445-4170

### 36. Northern Mechanical Sales

Garson, Ontario  
(705) 693-2715

### 37. Agencies J. Pierre Sylvain, Inc.

Boucherville, Que.  
(450) 655-9588  
Quebec, PQ  
(418) 570-0703

### 38. NerohTek Sales

Windsor, N.S.  
(902) 869-0103

### 39. Par Four Plumbing

St. Johns, N.F.  
(709) 739-7177

# WaterWorks Market Sales Reps

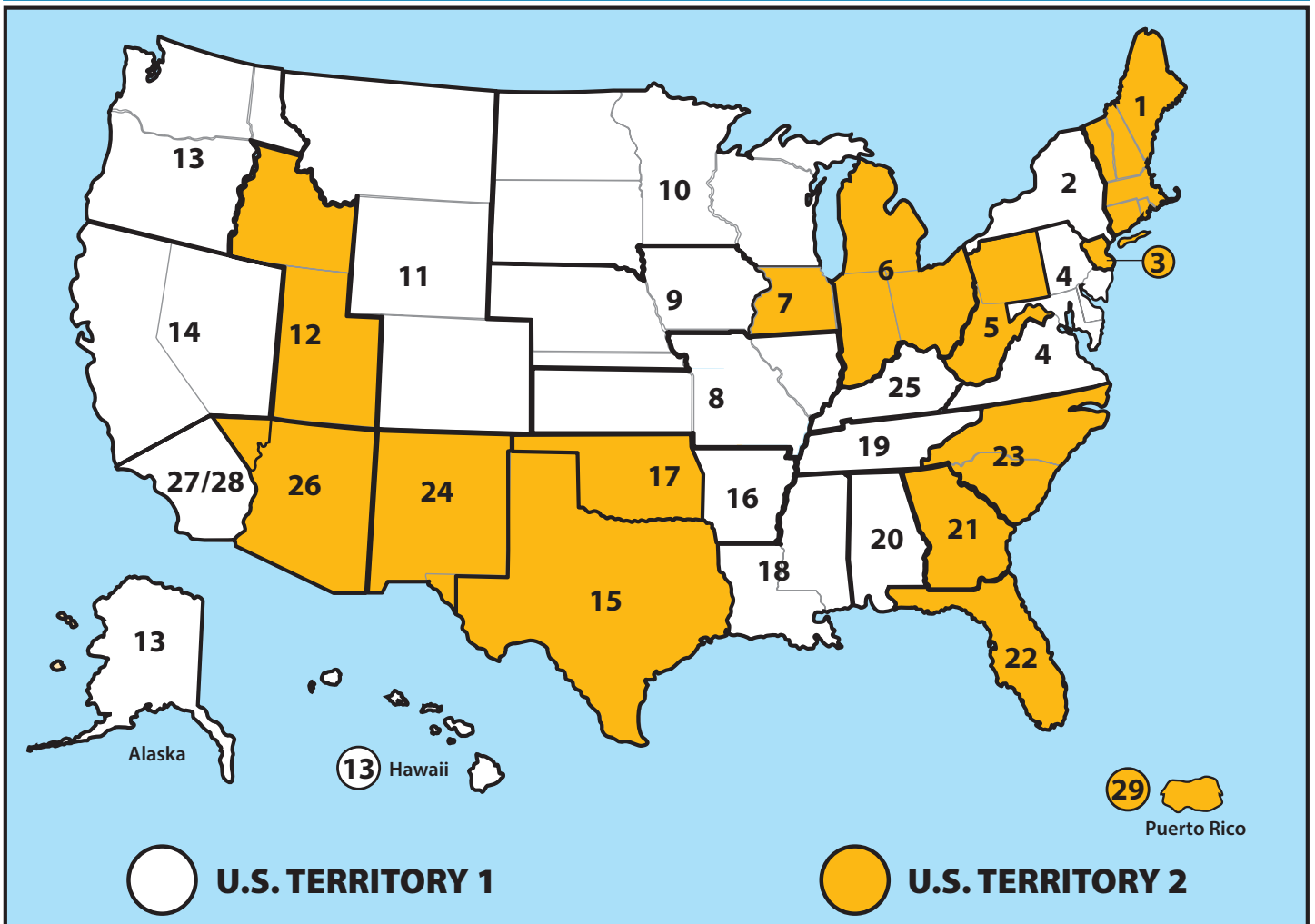
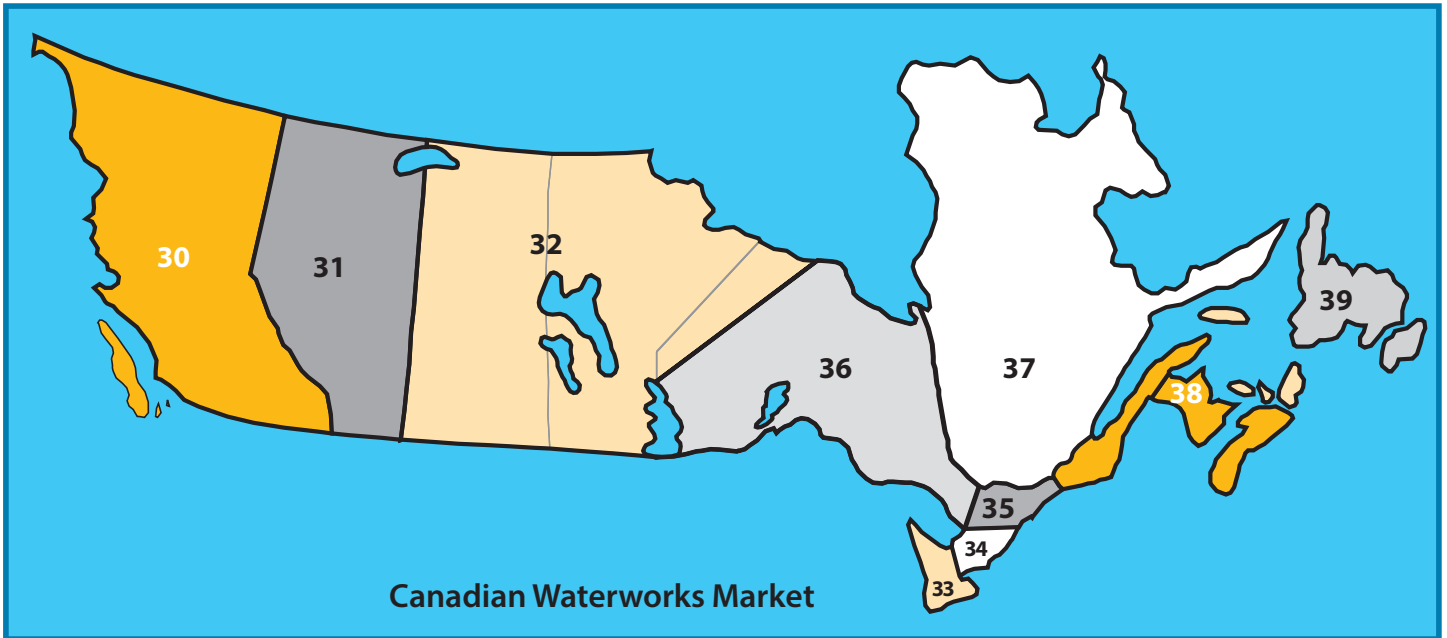

# Acid Resistance Chart

Maximum test pressure: 4.3 PSI (29.6 KPA)

Maximum operating temperature: 140° F non-consistent

R - Recommended N - Not Recommended

Reagent	Flexible Coupling 70°F	Proflex 70°F	Reagent	Flexible Coupling 70°F	Proflex 70°F	Reagent	Flexible Coupling 70°F	Proflex 70°F
Acetic Acid 20%	R	R	Disodium Phosphate	N	N	Silver Cyanide	R	R
Acetic Acid 80%	N	N	Distilled Water	R	R	Silver Nitrate	R	R
Acetone	N	N	Ethers	N	N	Silver Sulfate	R	R
Alcohol (Methyl or Ethyl)	R	R	Ethyl Acetate	N	N	Sodium Bicarbonate	R	R
Aluminum Chloride	R	R	Ethylene Chloride	N	N	Sodium Bisulfite	R	R
Aluminum Sulfate	R	R	Ethylene Glycol	R	R	Sodium Carbonate	R	R
Alums	R	R	Fatty Acids (C6)	R	R	Sodium Cyanide	R	R
Ammonia Gas (Dry)	R	R	Ferric Chloride	R	R	Sodium Ferrocyanide	R	R
Ammonium Chloride	R	R	Ferric Sulfate	R	R	Sodium Hydroxide	R	R
Ammonium Hydroxide	R	R	Fluorine (Gas Wet)	N	N	Sodium Hypochlorite	R	N
Ammonium Nitrate	R	R	Formaldehyde (20%)	R	R	Sodium Sulfate	R	R
Ammonium Phosphate	R	R	Formic Acid (10%)	R	R	Sodium Sulfide	R	R
Ammonium Sulfate	R	R	Freon 12 Dry	N	R	Sodium Sulfite	R	R
Ammonium Sulfide	R	R	Fruit Juices & Pulp	R	R	Sodium Thiosulfate	R	N
Amyl Chloride	N	N	Furfural	N	N	Stannic Chloride	R	N
Aniline	N	N	Gasoline (Refined)	N	N	Stannous Chloride	R	R
Aqua Regia	N	N	Glucose	R	R	Stearic Acid	R	R
Barium Chloride	R	R	Glycerine	R	R	Sulfite Liquor	R	R
Barium Hydroxide	R	R	Hydrobromic Acid (20%)	R	N	Sulfur	R	N
Barium Sulfate	R	R	Hydrochloric Acid	R	N	Sulfur Dioxide (Dry)	R	N
Barium Sulfide	R	R	Hydrocyanic Acid	R	R	Sulfur Dioxide (Wet)	R	N
Beer	R	R	Hydroquinone	R	N	Sulfuric Acid 50%	R	R
Beet Sugar Liquors	R	R	Hypochlorous Acid	R	N	Sulfuric Acid 70%	N	N
Benzene	N	N	Iodine	N	N	Sulfuric Acid 93%	N	N
Benzoic Acid	R	N	Kerosene	N	N	Sulfurous Acid	R	N
Black Liquor	R	R	Lactic Acid 25%	R	R	Tannic Acid	R	R
Bleach 12 5% active Cl <sub>2</sub>	R	N	Linseed Oil	R	R	Tanning Liquors	R	R
Boric Acid	R	R	Liquors	N	N	Tartaric Acid	R	R
Bromic Acid	R	N	Machine Oil	N	N	Toluene	N	N
Bromine Water	N	N	Magnesium Chloride	R	R	Trichloroethylene	N	N
Butane	N	R	Magnesium Sulfate	R	R	Triethanolamine	N	N
Butyric Acid	N	N	Maleic Acid	N	N	Trisodium Phosphate	R	R
Calcium Carbonate	R	R	Methyl Chloride	N	N	Turpentine	N	N
Calcium Chloride	R	R	Methyl Ethyl Ketone	N	N	Urea	R	R
Calcium Hydroxide	R	R	Milk	R	R	Urine	R	R
Calcium Hypochlorite	R	N	Mineral Oils	N	R	Vinegar	R	R
Calcium Sulfate	R	R	Muriatic Acid	R	N	Water (Fresh)	R	R
Cane Sugar Liquors	R	R	Nickel Chloride	R	R	Water (Salt)	R	R
Carbon Bisulfide	N	N	Nickel Sulfate	R	R	Whiskey	R	R
Carbon Dioxide	R	R	Nitric Acid 0-40%	R	N	Wines	R	R
Carbon Monoxide	R	R	Nitric Acid 41-100%	N	N	Xylene	N	N
Carbon Tetrachloride	N	N	Oleic Acid	N	N	Zinc Chloride	R	R
Carbon Acid	R	R	Oleum	N	N	Zinc Sulfate	R	R
Caustic Soda	R	N	Oxalic Acid	R	R			
Caustic Soda 50%	R	R	Palmitic Acid 10%	R	R			
Caustic Potash	R	R	Perchloric Acid	N	N			
Chloride (Dry)	N	N	Petroleum Oils (Sour)	N	N			
Chloride (Wet)	N	N	Phenol 5%	N	N			
Chloroacetic Acid	N	N	Phosphorous Trichloride	N	N			
Chlorobenzene	N	N	Photographic Solutions	R	R			
Chloroform	N	N	Picric Acid	N	N			
Chromic Acid 10%	R	N	Plating Solution	R	R			
Chromic Acid 50%	N	N	Potassium Carbonate	R	R			
Citric Acid	R	R	Potassium Chlorate	R	R			
Copper Chloride	R	R	Potassium Chloride	R	R			
Copper Cyanide	R	R	Potassium Cyanide	R	R			
Copper Nitrate	R	R	Potassium Dichromate	R	R			
Copper Sulfate	R	R	Potassium Hydroxide	R	R			
Cottonseed Oil	R	R	Potassium Permanganate 10%	R	R			
Cresol	N	N	Potassium Sulfate	R	R			
Cyclohexanol	N	R	Propane Gas	R	R			
Cyclohexanone	N	N	Propyl Alcohol	R	R			
Dimethylamine	N	N	Sea Water	R	R			
Diocyl Pthalate	N	N	Sewerage	R	R			

**NOTE:** The data listed in this table is only to give information in regard to general use and does not constitute a guarantee. Materials should be tested under actual service to determine suitability for a particular purpose.



# TERMS

*All prices shown are Trade/List, stated in U.S. currency and subject to change without notice*

**MINIMUM INVOICE** - None

**PAYMENT TERMS** - 1% 10th prox. NET 30 days unless otherwise stated. Shortage claims must be made to Fernco within 15 days after delivery

**FREIGHT TERMS** - Prepaid and allowed on net order of \$750.00 or more unless otherwise stated. All others will be prepaid and billed. Claims for loss or damage must be filed with the freight carrier

**SALES POLICY** - Fernco products are available to any legitimate wholesaler, pipe manufacturer or distributor with approved credit

**RETURN POLICY** - All returns must be preceded by factory authorization. Minimum 15% restocking charge will apply to all standard Fernco products. All materials returned to Fernco should be in original cartons and be in resalable condition. This amount is subject to change depending on condition of items returned to Fernco

- Fernco Custom Parts are Non-Refundable
- Freight must be prepaid on all return shipments
- Returns will not be allowed after 90 days of invoice date

## LIMITED WARRANTY

Fernco warrants its product(s) against defects in workmanship or materials for one (1) year from date of original purchase (unless a shorter period is expressly provided with respect to a particular product). Fernco's total liability under any warranty, or any other claim arising in any way from the product or its use, is limited, at Fernco's option, to refund or replacement of any such product returned to Fernco within the one-year warranty period and determined by Fernco to be defective. To the extent permitted by law, Fernco disclaims and excludes any and all other warranties, express or implied, including without limitation any implied warranty of merchantability or fitness for a particular purpose, and in no event shall Fernco be liable for special, incidental or consequential damages. Failure to follow the installation instructions provided by Fernco will void this warranty. To make a warranty claim, purchaser should have the original receipt and contact Fernco, Inc. Customer Service Department, 810 503-9000. Purchaser is responsible for any shipping charges.

If state law preserves implied warranties, including implied warranties of merchantability and fitness for a particular purpose, such warranties are limited to one-year from the date of the original purchase and as otherwise set forth above. Some states do not allow limitations on how long an implied warranty lasts, or the exclusion of incidental or consequential damages, so such limitation(s) or exclusion(s) may not apply to you.

This written warranty gives you specific legal rights, and you may also have other rights which vary from state to state.

### Fernco, Inc.

300 S. Dayton St.  
Davison, MI 48423  
fernco.com  
P: (810) 503-9000  
F: (810) 503-1015

### Fernco West

855 Linda Way  
Sparks, NV 89431  
fernco.com  
P: (810) 503-9000  
F: (810) 503-1015

### Fernco Connectors LTD

850 Philip Street E.  
Sarnia, Ontario N7T 1Z6  
fernco.ca  
P: (519) 332-6711  
F: (519) 332-8610



**PROVEN. PREFERRED. PROFESSIONAL.**