

ASTM A182 STAINLESS HIGH PRESSURE FITTINGS

UNION - SOCKET

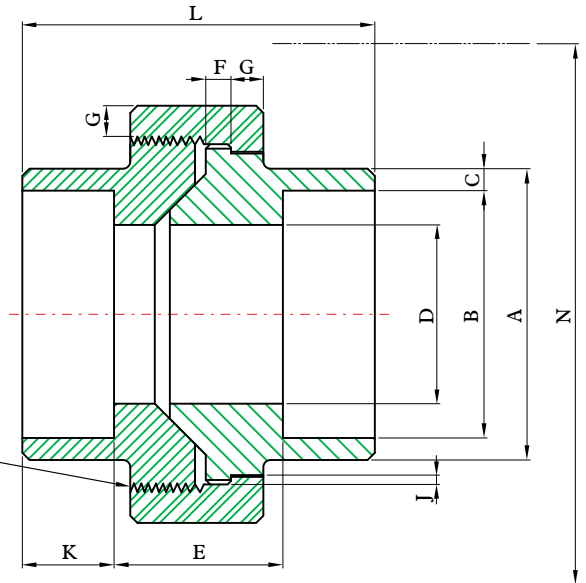

H-Thrd's
Minimum 4 Full Thrd's
Engagement Class 2A/2B Fit



DIMENSIONS

unit : inch

Nom. Pipe Size	Pipe End	Socket Bore Dia.	Socket Wall	Water Way Bore	Laying Length	Male Flange	Nut	Thrds. Per 25.4mm Max. H	Bearing Min. J	Depth of Socket Min. K	Length Assem. Nom. L	Clear Assem. Nut N
	Min. A	B	Min. C	D	E	Min. F	Min. G					
1/8	0.858	0.430 0.420	0.125	0.269 0.253	0.882 0.748	0.125	0.125	0.630	0.049	0.378	1.630	1.929
1/4	0.858	0.560 0.550	0.130	0.388 0.372	0.882 0.748	0.125	0.125	0.630	0.049	0.378	1.630	1.929
3/8	1.020	0.700 0.690	0.137	0.548 0.532	1.059 0.811	0.135	0.135	0.551	0.054	0.378	1.811	2.165
1/2	1.228	0.860 0.850	0.160	0.688 0.672	1.059 0.811	0.145	0.145	0.551	0.059	0.378	1.929	2.244
3/4	1.461	1.070 1.060	0.168	0.858 0.842	1.252 1.000	0.160	0.160	0.433	0.066	0.500	2.240	2.638
1	1.791	1.340 1.330	0.195	1.108 1.092	1.350 1.031	0.180	0.175	0.433	0.073	0.500	2.441	3.110
1-1/4	2.161	1.680 1.670	0.208	1.408 1.392	1.598 1.280	0.210	0.205	0.433	0.084	0.500	2.799	3.701
1-1/2	2.421	1.920 1.910	0.218	1.638 1.622	1.661 1.339	0.230	0.220	0.394	0.091	0.500	3.012	4.370
2	2.961	2.420 2.410	0.238	2.068 2.052	1.791 1.469	0.260	0.250	0.394	0.106	0.622	3.390	5.197
2-1/2	3.610	2.920 2.900	0.301	2.548 2.532	2.429 2.051	0.295	0.280	0.315	0.121	0.622	4.031	5.827
3	4.299	3.550 3.530	0.327	3.058 3.042	2.512 2.110	0.325	0.315	0.315	0.139	0.622	4.291	6.890

