

30" X 30" Junction Box

Specifications:

1. Concrete: Has a Design Strength of 5,000 psi at 28 Days.
2. Steel Reinforcement: ASTM A-615, Grade 60 or ASTM A-497 Welded Wire Fabric.
3. Loading: Designed for H20 Loading.

Weights

Catch Basin Weight - 3,625 Lbs.

Slab Top Weight - 675 Lbs.

Extension Weight (12") - 900 Lbs.

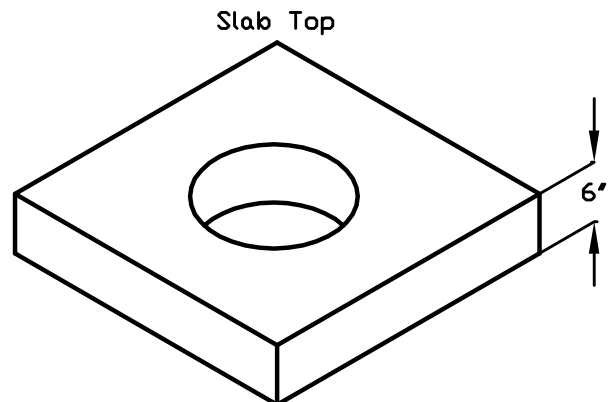
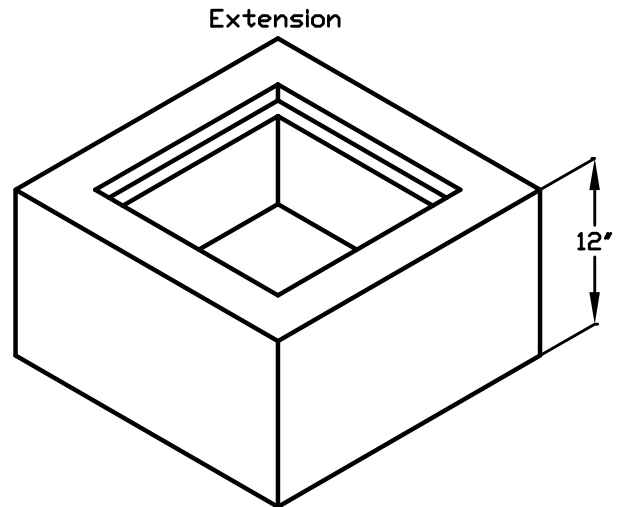
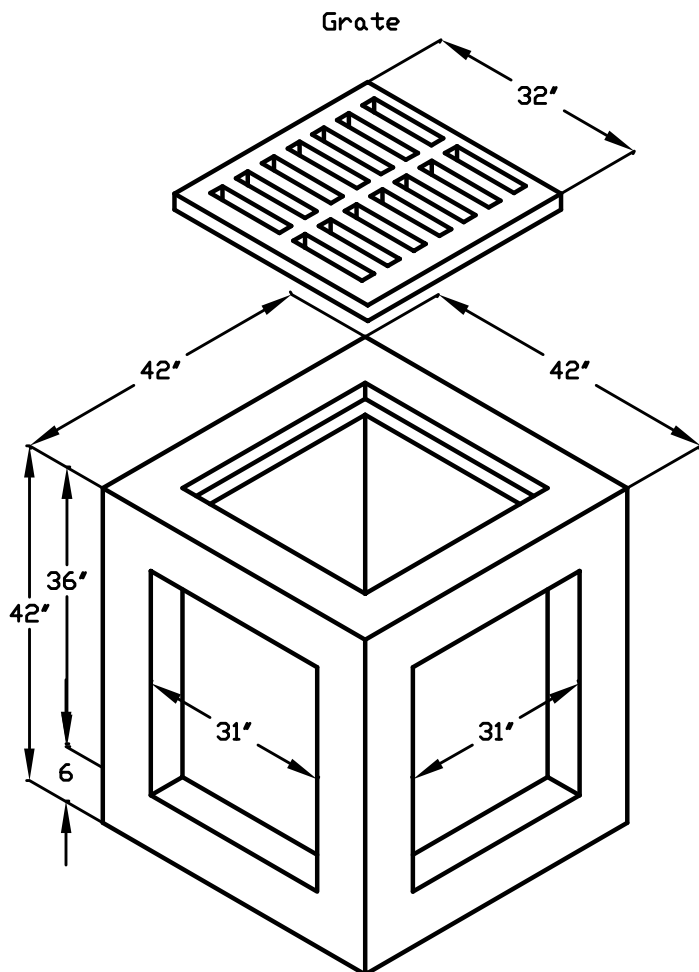

The Turner Company		11049 Highway 287 Rhame, Tx 76078 (817) 638-9053
Product: 30" x 30" Junction Box		
Concrete: 5,000 PSI MIN. - 28 DAY STRENGTH		
Reinforcement: MEETS OR EXCEEDS ASTM A-615 or A-185 REQ.		
Size:	Date:	DWG No.
Weight:		