

heliodyne
SOLAR HOT WATER

2014 PRODUCT GUIDE

EXCELLENCE
BY DESIGN®



HELIODYNE - FOR ALL APPLICATIONS

Security of energy supply, climate issues and economic growth are important to political stakeholders now more than ever. It's therefore expected that legislatures will make a stronger and stronger push for measures which can lower demand by increasing energy efficiency and encourage use of renewable technology. Almost 50% of the total annual energy demand in the US is used for heating and cooling requirements, mainly in buildings. Solar thermal energy will therefore be one of the most important energy sources for the future.

Demand for solar thermal equipment will come in many different forms and will reflect the different applications its applied to, such as new construction, existing buildings or commercial. Whereas new construction will require aesthetically pleasing solutions, solar thermal for existing buildings will emphasize ease of installation, plug and play and low cost. By adding VELUX roof-integrated collectors and SOLPAL integrated collector storage systems to its product lines, Heliodyne is now able to cater to all needs in the US solar thermal market.

VELUX Roof-Integrated Collectors

The VELUX roof-integrated collectors have been designed to hug the roofline, creating a streamlined, aesthetically pleasing appearance. The VELUX roof-integrated collectors have the same low profile look and performance as the VELUX skylights and roof windows used for years throughout the U.S.

SOLPAL Integrated Collector Storage System

The SOLPAL product is designed as an inexpensive solar hot water system, tying into the existing hot water tank and serving as a preheater. It's therefore very simple and cost competitive. With current low natural gas prices, the SOLPAL will be financially feasible where more conventional solar hot water systems are not, and with its contemporary style it fits the roof, garden or terrace in any modern home as an integral design element.

HELIODYNE Commercial Solar Hot Water Systems

The GOBI collector has one of the highest collector outputs on the market, optimizing performance incentives and equipment costs, and providing best value for commercial SHW applications.



The pre-engineered and factory assembled HCOM commercial SHW station, with so many unique features, takes the specialized skill out of installing commercial SHW and lowers the liability, reducing the risks for both engineers and contractors.

With more than 35 years of experience in solar hot water, in-house engineering, readily available sales tools and exceptional staff, we believe Heliodyne is the best partner to help you build your SHW business in the United States.

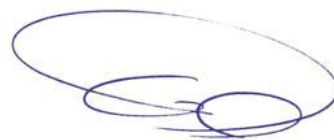

Ole Pilgaard
President, Heliodyne, Inc.

CONTENTS

New Products	1
Tools For Industry Professionals	2-4
PSP Method	5
Heliodyne Solutions	6-11
Indirect Water Heating	6
Direct Water Heating	8
Space Heating	10
Integral Collector Storage Systems	12-13
The GOBI Collector	14
The Dyn-O-Seal System	15
GOBI Mounting Hardware	16-17
Heat Transfer Appliances	18-20
Solar Flex Tube	21
Compliance Kits	22
Commercial Solar Station	23-24
Control Units	25-26
Heat Exchangers, Tanks & Accessories	27
Roof-Mount Kits	28
Parts & Accessories	29-30

Unless otherwise stated, all products have an estimated 2-week outbound lead time.

NEW FOR 2014!

Heliodyne is proud to introduce its newest products, along with their special features.

HELIODYNE SOLUTIONS

New OG-300 certified single tank systems save space and lower overall system cost.

(See pages 6-11)



THE SOLPAL ICS COLLECTOR

- No pumps or electricity needed
- Easiest to install
- Industry top performer

(See page 14)



SRCC OG-300 COMPLIANT KITS

compliant plumbing fixtures for Bradford White tanks reduce hours on the job site. (See page 24)



UNISTRUT KIT

Front and rear brackets to use with unistrut rail. (See page 25)
The preassembled SRCC OG-300



TOOLS FOR OUR INDUSTRY PROFESSIONALS

Heliodyne prides itself on its customer service and support. Our goal is to ensure that the industry professionals we work with are equipped with all the tools necessary to assist them with the design, sale and installation of a SHW system.

DEALER LOCATOR

Online installer search tool for a homeowner looking for a local authorized Heliodyne installer.



INSTALLATION TRAINING

Two training programs are currently available, classroom or Heliodyne's online training, both of which cover residential and commercial SHW fundamentals.



SOLAR SIMULATION TOOLS

A FREE web-based version provides quick, basic system sizing and performance calculations, while a more expanded version can be purchased and installed on any Windows™ based computer.



PRINT MATERIALS

Assortment of print marketing collateral (brochures, case studies, etc.) that educate and promote SHW to the end user.



HELIO-PARTNER PROGRAM

Customer loyalty program available to solar dealer installers and solar contractors. Provides valuable perks such as discounts on marketing tools and preferred listing on the dealer locator, and access to Heliodyne marketing collateral.



LIVE CASE STUDIES

Using the internet-enabled capabilities of the Delta-T Pro controller, each case study on Heliodyne's website posts real-time energy output so the viewer can see just how effective Heliodyne SHW systems are.



FINANCIAL FEASIBILITY CALCULATOR

Downloaded from Heliodyne.com, this spreadsheet tool is used to perform site specific project feasibility assessments for Heliodyne SHW systems.

SYSTEM DESIGN SUPPORT

Our engineering staff is available to assist engineers and commercial installers with the design of large-scale SHW systems.

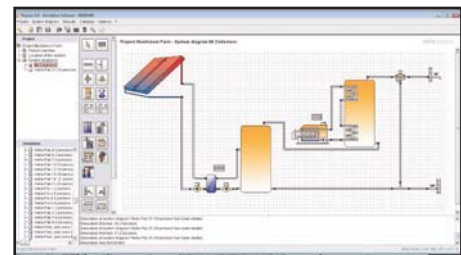

SPECIFICATIONS AND DRAWINGS

Complete specifications and CAD drawings available for all Heliodyne collectors and other SHW components to make incorporating Heliodyne products into your project documents quick and easy.



INSTALLATION AND MARKETING TOOLS

GLYCOL TEST KIT ITLS 000 001

Test kit for closed loop system maintenance. Includes: pH buffer solution, pH meter cleaning solution, pH meter and refractometer.

FILL PUMP KIT ITLS 000 002

Fill pump with tank, hose, and pressure pump connection on the side.

SOLAR SIMULATION SOFTWARE ITLS 000 003

Simple to use SHW performance software to aid in system design for residential and small commercial projects. Features various input parameters, accurate energy output estimations and illustrations on all Heliodyne residential system components. Windows™ compatible only.

RETRACTABLE BANNER PTLIS 000 003

A valuable tool for your showroom or tradeshow. Measures approx. 36" x 80" and comes with a carrying bag for easy transportation.

WALL BANNER PTLIS 000 004

Our 7' x 2' heavy-gauge vinyl banner is an economical choice for promoting solar hot water.

SALES KIT PTLIS 000 005

Includes: Sales Flip Chart, Questionnaire Pad and assorted sample print materials (spec. sheets, case studies, etc.)

MINI GOBI PTLIS 102 001

A miniature version (approx. 18" x 32") of our GOBI collector. The mini GOBI comes factory assembled with the same components that are used in the full-scale version.

HLAB HLAB 000 000

The HLAB is a compact, mobile, fully working closed loop SHW system. Its main function is to serve as a portable system for educational or product demonstration purposes.



(Fold-up stand included)

PRESSURE STAGNATION PROTECTION METHOD

Pressure Stagnation Protection (PSP) Method

The PSP method will prevent glycol breakdown during periods of system stagnation provided these three simple rules are followed:



1. High-temperature HD glycol is used
2. Size expansion tank acceptance volume is 19%–22% of total system volume
3. The operating pressure of the system does not exceed 150 psig

Heliodyne pressure tests all components at 300 psig – higher than any other manufacturer – to ensure our equipment is fully compatible with the PSP method of protection.

Background

In closed loop pressurized systems, if the storage tank reaches its high temperature limit, the solar thermal controller will turn off the solar circulators, causing stagnation in the solar loop. The sun will continue to heat the collectors, and over time the internal collector temperature will increase until it reaches a steady-state stagnation temperature, at which point the system balances the heat exchange from the solar thermal radiation to the ambient surroundings, see Figure 1. For most areas in the United States, the steady-state stagnation temperature for blue sputter GOBI collectors will be between 300–350°F. At steady-state stagnation conditions, the temperature and pressure of the system are at their maximum values, and the system is at the highest risk of boiling the internal fluid.

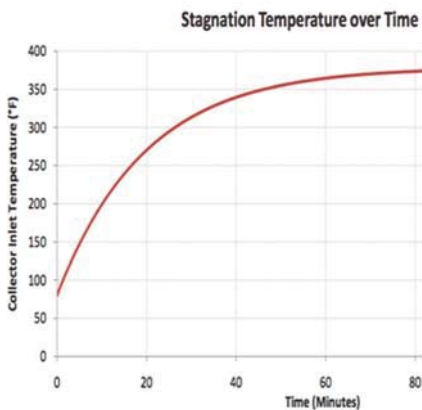

Figure 1: Temperature rise during stagnation

In areas of potential freezing, propylene glycol solution is used as the solar operating fluid for freeze protection. If propylene glycol remains in a liquid state, it can have a service life of 10 years. If glycol is allowed to boil, the inhibitors within the solution will break down, thus destroying the glycol's freeze protection properties, and must be flushed out and replaced in shorter intervals.

Therefore, to keep the glycol in a liquid state at all times and prolong service life, the solar system design must balance system operating pressures and temperatures to avoid boiling in the collectors during periods of steady-state stagnation.

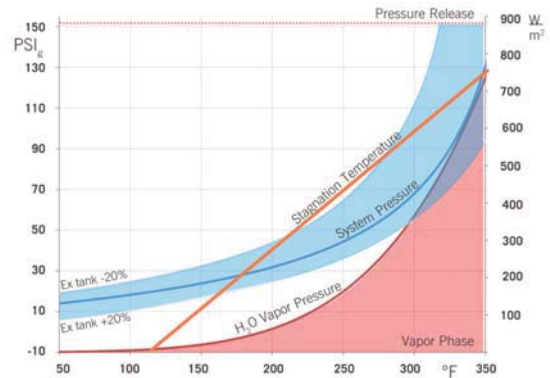

Figure 2: Collector system pressure behavior

The PSP method uses this basic law of physics: If the pressure of a closed loop system is kept above the liquid-vapor transition point, the operating fluid will stay in a liquid state. In other words, the system pressure in a PSP system can increase up to and including stagnation conditions, and still keep glycol in a liquid state at all times, preventing glycol breakdown.

The key elements to a successful PSP system are:

1. All equipment must be able to operate at the high pressures expected during stagnation temperatures (up to 150 psig maximum operational pressure).
2. Glycol designed for high temperature use (e.g., DYN-O-FLO HD glycol, rated at 325°F for continuous usage, and 375°F for periodic usage.)
2. Expansion tank sized between 17%–22% of total system volume to control system pressure above the vapor transition curve up to and including stagnation conditions.

A properly designed system using the PSP method operates at the System Pressure curve in Figure 2, maximizing system temperature while staying above the fluid-vapor pressure. If the expansion tank is oversized by 20%, the system will cause the fluid to flash to steam at approximately 300°F. If the expansion tank is undersized by 20%, fluid will release from a pressure release valve at 150 psi.

All Heliodyne equipment is pressure tested to 300 psig and can withstand the high pressures and temperatures occurring in a PSP system. All Heliodyne heat transfer appliances are fitted with 150 psig pressure relief valves and use Heliodyne DYN-O-FLO antifreeze liquid to ensure a very long service life and minimal maintenance costs.

HELIODYNE SOLUTIONS

SINGLE TANK SOLUTIONS: INDIRECT WATER HEATING

Indirect solar water heating is the most common solution for most installations in North America. This system utilizes a closed loop design which protects it from freezing and hard water issues. Because the Helio-Pak has an external heat exchanger, a single tank SHW system is easy to configure and is more cost- and space-efficient when compared to a traditional dual tank or coil-in-tank closed loop system.

Features

- Plug & Play installation
- Can be used unconditionally in all areas
- Closed loop design protects from freezing and hard water
- Ideal for installations with limited equipment space
- Helio-Pak allows for compatibility with nearly all tank manufacturers
- Cost competitive with other closed loop systems

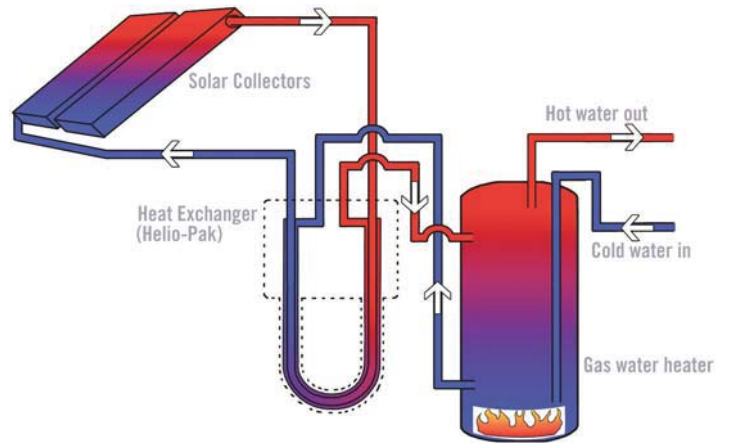

Components include:

- 1 - Helio-Pak heat transfer appliance with built-in Delta-T or Delta-T Pro Lite Controller
- 2 - Tank (80 or 120 gallon)
- 3 - GOBI blue sputter flat plate collectors
- 4 - Roof mounting hardware - single collector
- 5 - Expansion tank (included with HPAK)
- 6 - Dyn-O-Flo heat transfer fluid
- 7 - Dyn-O-Seal™ Disc Unions (2 required)
- 8 - Sensor wire



heliodyne
SOLAR HOT WATER SOLUTIONS

HELIODYNE SAMPLE SYSTEMS

The following systems are all single tank SHW solutions designed for a four-person household. The systems utilize Heliodyne solar collectors, tanks, and pump station components, which are available from Heliodyne. Each of these systems are Energy Star™ and SRCC™ certified, which qualifies them for federal and state incentives.*

HELIODYNE CLOSED LOOP WITH 4500 WATT ELECTRIC BACKUP - SRCC Certification #2009034B

COMPONENTS	DESCRIPTION	QTY	SAMPLE SYSTEM COST	Price
GOBI 410 001	GOBI 410 Blue Sputter Collector	1	System cost	\$5,892 +
HPAK TKIT 80E 1F	HPAK Tank Kit, 80 gal electric b/u for 1 Gobi, Flush	1	Installation costs (labor, piping)	\$1,500 +
ZFM 015	Corrugated Stainless Steel Flextubes (50')		Less state rebate*	- \$1,000 -
			Less 30% federal tax credit	- \$2,218 -
			Estimated deferred cost of water heater replacement (installed)	- \$1,250 -
MSRP SUBTOTAL \$5,892			Estimated incremental solar system cost for the homeowner:	\$2,924
			<i>Estimated annual energy savings: 3,479 kWh</i>	<i>Estimated ROI: 5 years</i>

HELIODYNE CLOSED LOOP WITH 4500 WATT ELECTRIC BACKUP - SRCC Certification #20090340

COMPONENTS	DESCRIPTION	QTY	SAMPLE SYSTEM COST	Price
GOBI 410 001	GOBI 410 Blue Sputter Collector	2	System cost	\$8,949 +
HPAK TKIT 80E 2F	HPAK Tank Kit, 120 gal electric b/u for 2 Gobi, Flush	1	Installation costs (labor, piping)	\$2,500 +
ZFM 020	Corrugated Stainless Steel Flextubes (65')	2	Less 30% federal tax credit:	- \$3,435 -
			Less 25% NY state tax credit up to \$5,000	- \$2,004 -
			Less NY Solar Thermal Incentive rebate up to \$4,000	- \$4,000 -
			Estimated deferred cost of water heater replacement (installed)	- \$1,500 -
MSRP SUBTOTAL \$8,949			Estimated incremental solar system cost for the homeowner:	\$510
			<i>Estimated annual energy savings: 3,240 kWh</i>	<i>Estimated ROI: 2 years</i>

HELIODYNE CLOSED LOOP WITH TANKLESS BACKUP - SRCC Certification #2010136K

COMPONENTS	DESCRIPTION	QTY	SAMPLE SYSTEM COST	Price
GOBI 410 001	GOBI 410 Blue Sputter Collector	2	System cost	\$8,949 +
HPAK TKIT 120E 2F	HPAK Tank Kit, 120 gal electric b/u for 2 Gobi, Flush	1	Installation costs (labor, piping)	\$3,500 +
ZFM 020	Corrugated Stainless Steel Flextubes (65')	2	Less 30% federal tax credit:	- \$3,735 -
			Less 25% NY state tax credit up to \$5,000	- \$2,179 -
			Less NY Solar Thermal Incentive rebate up to \$4,000	- \$4,000 -
			Estimated deferred cost of water heater replacement (installed)	- \$1,500 -
MSRP SUBTOTAL \$8,949			Estimated incremental solar system cost for the homeowner:	\$1,035
			<i>Estimated annual energy savings: 196 gal. propane</i>	<i>Estimated ROI: 2 years</i>

*Specific incentives were applied in this sampling, however many other states also have incentives. Visit www.dsireusa.org for a complete list.
Note: Heliodyne takes no responsibility for the availability of any rebates or incentives.

HELIODYNE SOLUTIONS

SINGLE TANK SOLUTIONS: DIRECT WATER HEATING

Direct solar water heating is an excellent choice for regions where freezing and water quality are not an issue. This system utilizes an open loop design which efficiently provides directly heated water to the potable water supply. By using the Helio-Flo heat transfer appliance, a single tank configuration can provide a low cost SHW solution that takes up minimal space.

Features

- “Plug & Play” installation
- Efficient direct water circulation
- Low cost system
- Ideal for installations with limited equipment space
- Mild freeze protection included
- Compatible with most major tank manufacturers



heliodyne
SOLAR HOT WATER SOLUTIONS

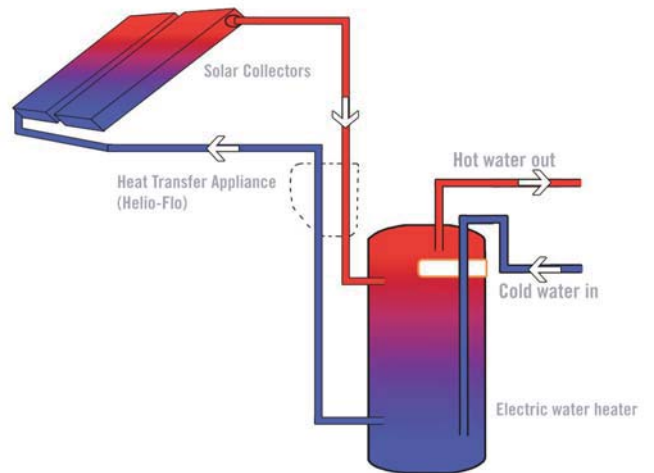

Guidelines for using open loop systems:

Heliodyne recommends using an open loop system if the following conditions are met:

- Locations where ambient temp. never falls below 42°F
- Water hardness measures less than 100ppm

If these basic conditions cannot be met, it's advisable to install a closed loop system instead.

Note: Heliodyne takes no responsibility for freeze damage

Components include:

- 1 - Helio-Flo Heat Transfer Appliance with built-in Delta-T or Delta-T Pro Lite controller
- 2 - Tank
- 3 - GOBI flat-plate collectors
- 4 - Roof mounting hardware - single collector
- 5 - Dyn-O-Seal™ Disc Unions (2)
- 6 - Sensor wire

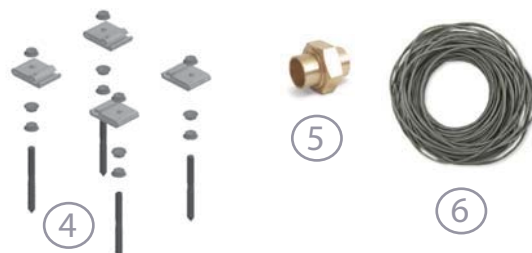

HELIODYNE SAMPLE SYSTEMS

The following systems are all single tank SHW solutions designed for various household sizes. The systems utilize Heliodyne solar collectors, tanks, and pump station components all available from Heliodyne. Each of these systems are Energy Star™ and SRCC™ certified which qualifies them for federal and state incentives.*

OPEN LOOP WITH 4500 WATT - 65 GALLON ELECTRIC BACKUP - SRCC Certification #2001023K

COMPONENTS	DESCRIPTION	QTY
GOBI 410 001	GOBI 410 Blue Sputter Collector	1
ZZZZ 001 000	DOS Disc Unions (2)	2
FLSH 001 000	Single Collector Flush Mount Kit	1
HFLO 016 000	Helio-Flo Standard Open Loop Heat Transfer Appliance	1
SENS 000 002	100' Sensor Wire	1
TFF 065 0205	65 Gallon Solar Storage Tank w/ Electric Element	1

MSRP SUBTOTAL \$3,645

SAMPLE SYSTEM COST	Price
System cost	\$3,645 +
Installation costs (labor, piping, ancillary Heliodyne components**)	\$2,000 +
Less Hawaii Energy solar water heater rebate*	- \$750 -
Less 35% Hawaii Solar & Wind energy credit	- \$1,976 -
Less 30% federal tax credit	- \$1,694 -
Est. deferred cost of water heater replacement (installed)	- \$1,250 -

Estimated incremental solar system cost for the homeowner: \$0

Estimated annual energy savings: 3,271 kWh

Estimated ROI: 0 years

OPEN LOOP WITH 4500 WATT - 80 GALLON ELECTRIC BACKUP - SRCC Certification #2001023B

COMPONENTS	DESCRIPTION	QTY
GOBI 410 001	GOBI 410 Blue Sputter Collector	1
ZZZZ 001 000	DOS Disc Unions (2)	2
FLSH 001 000	Single Collector Flush Mount Kit	1
HFLO 016 000	Helio-Flo Standard Open Loop Heat Transfer Appliance	1
SENS 000 002	100' Sensor Wire	1
VST 080 0205	80 Gallon Solar Storage Tank w/ Electric Element	1

MSRP SUBTOTAL \$3,817

SAMPLE SYSTEM COST	Price
System cost	\$3,817 +
Installation costs (labor, piping, ancillary Heliodyne components**)	\$2,000 +
Less Hawaii Energy solar water heater rebate*	- \$750 -
Less 35% Hawaii Solar & Wind energy credit	- \$2,036 -
Less 30% federal tax credit	- \$1,745 -
Est. deferred cost of water heater replacement (installed)	- \$1,250 -

Estimated incremental solar system cost for the homeowner: \$36

Estimated annual energy savings: 3,169 kWh

Estimated ROI: < 1 year

OPEN LOOP WITH 4500 WATT - 120 GALLON ELECTRIC BACKUP - SRCC Certification #2001023C

COMPONENTS	DESCRIPTION	QTY
GOBI 410 001	GOBI 410 Blue Sputter Collector	1
ZZZZ 001 000	DOS Disc Unions (2)	2
FLSH 001 000	Single Collector Flush Mount Kit	1
HFLO 016 000	Helio-Flo Standard Open Loop Heat Transfer Appliance	1
SENS 000 002	100' Sensor Wire	1
TFF1200205US	Bradford White 120 Gallon Solar Storage Tank w/ Electric Element	1

MSRP SUBTOTAL \$4,530

SAMPLE SYSTEM COST	Price
System cost	\$4,530 +
Installation costs (labor, piping, ancillary Heliodyne components**)	\$2,000 +
Less Hawaii Energy solar water heater rebate*	- \$750 -
Less 35% Hawaii Solar & Wind energy credit	- \$2,250 -
Less 30% federal tax credit	- \$1,959 -
Est. deferred cost of water heater replacement (installed)	- \$1,250 -

Estimated incremental solar system cost for the homeowner: \$321

Estimated annual energy savings: 4,159 kWh

Estimated ROI: < 1 year

*Specific state incentives were applied in this sampling, however, many other states also have incentives. Visit www.dsireusa.org for a complete list.

**Ancillary Heliodyne hardware reduces hours on the job site and includes DOS Combo fitting (page 17), OG-300 Valve block (page 24) and Roof Mounting Kit (page 18).

Note: Heliodyne takes no responsibility for the availability of any rebates or incentives.

HELIODYNE SOLUTIONS

SOLAR WATER HEATING & SPACE HEATING (COMBINATION SYSTEMS)

Heliodyne now offers a single tank solution for SHW/space heating systems. This is accomplished by utilizing the Smart Multi-Energy (SME) tank manufactured by TriangleTube. The new solar “hybrid” tank is essentially a tank within a tank, with the outer tank being used for the space heating system and the inner tank used for potable hot water. A boiler provides backup heating and maximum energy efficiency.

Features

- “Plug & Play” installation
- Simple solution for combination systems
- Single tank configuration saves space
- Fully protected from overheating and freezing

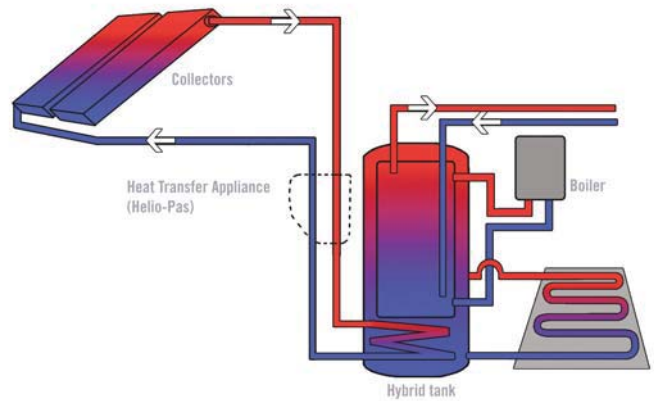

Components include:

- 1 - SME Hybrid tank*
- 2 - Helio-Pass heat transfer appliance with Pro controller
- 3 - GOBI collectors with DOS disc unions
- 4 - Prestige Excellence Boiler
- 5 - Roof mount kit for three collectors
- 6 - Expansion tank
- 7 - Dyn-O-Flo heat transfer fluid
- 8 - Sensor wire



heliodyne / **TriangleTube**
SOLAR SPACE & HOT WATER SOLUTIONS

*Heliodyne does not sell or distribute third party tanks. Please contact your Heliodyne representative if you need assistance purchasing these tanks.

How It Works

The HPAS operates the SHW loop, pumping heated glycol through the coils in the bottom of the hybrid tank. The heated coils then heat the water in the outer tank. This water is used for the radiant floor loop. That water in turn will also heat the potable water housed within the inner tank of the hybrid tank. If the water in the inner tank is not hot enough, the backup boiler will boost the temperature.

ANATOMY OF AN SME HYBRID TANK

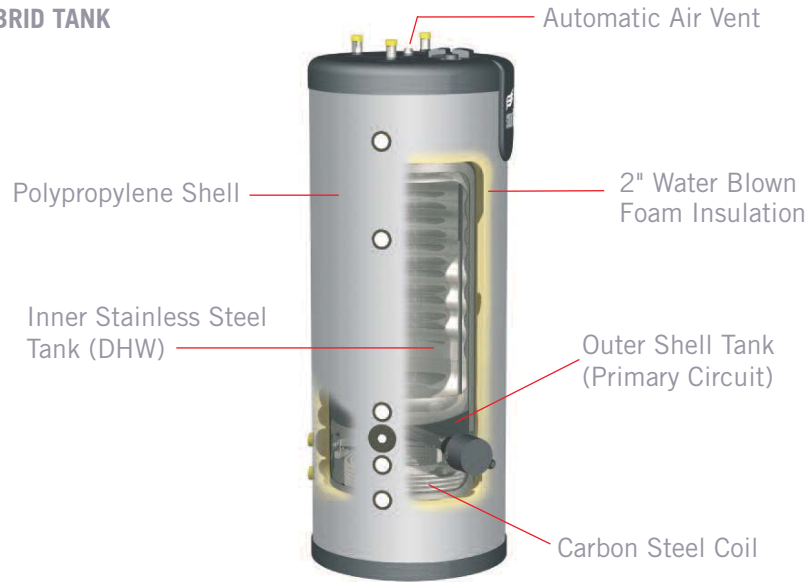

SAMPLE SYSTEM

The following system provides a sample cost for a four-person home with 1000 ft² of radiant floor heating. Heliodyne components are used in conjunction with a Triangle Tube SME Hybrid tank for a single tank combination system solution. A Traingle Tube Prestige boiler is used to provide backup heating.

COMPONENTS	DESCRIPTION	QUANTITY
GOBI 410 001	GOBI 410 Blue Sputter Collector	3
ZZZZ 001 000	DOS Disc Unions	2
Collector Hardware	Collector Mounting Hardware for 3 Collectors	1
HPAS 016 012	Helio-Pass with Delta-T Pro Lite Controller	1
SENS 000 002	100' Sensor Wire	1
DFLO 004 004	4 Gallons of Dyn-O-Flo Heat Transfer Fluid	1
SME 60*	160 Gallon Hybrid Tank	1
Boiler*	Prestige Boiler	1

*Heliodyne does not sell or distribute 3rd party tanks or boilers. Please consult your Heliodyne representative if you need assistance purchasing components.

**Estimated MSRP does not include installation costs.

MSRP SUBTOTAL \$14,100**

SOLPAL INTEGRAL COLLECTOR STORAGE SYSTEMS

With a Solpal integral collector storage systems it is easier than ever to harness the sun's energy to generate hot water. Solpal is a solar water heater that feeds into your existing hot water system. It ties into your water supply line and preheats the water before it enters your existing water heater. The method is simple, yet ingenious: Water is heated and stored within the solar collector, eliminating the need for circulation pumps and an external power supply.

Features

- Integrated collector storage systems suitable for warm climates
- Easy installation on flat or pitched roofs
- Low profile design can be installed flush to roof for superior look
- Low cost solar system solution
- More efficient than traditional thermosyphon systems
- Half the size of traditional thermosyphon system.

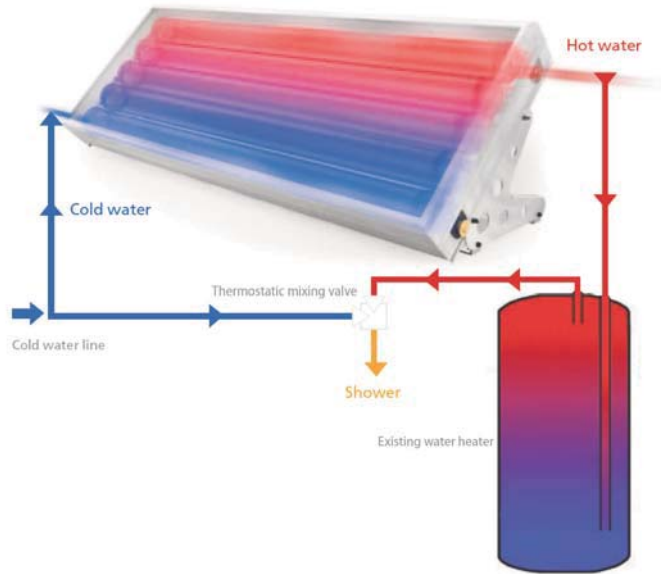

Components include:

- 1 - Solpal integral collector storage system
- 2 - Mounting brackets
- 3 - Valves and fittings
- 4 - Solpal mounting hardware



INTEGRAL COLLECTOR STORAGE SAMPLE SYSTEMS

The following systems are Solpal single tank SHW packaged solutions designed for a four-person household. The systems utilize Solpal ICS solar components, which are available from Heliodyne. Each of these systems is SRCC™ certified, which qualifies them for federal and state incentives. The samples presented are typical, but not specific to any particular state. Visit www.dsireusa.org for specific incentives in your area.

INTEGRAL COLLECTOR STORAGE SYSTEM WITH ELECTRIC BACKUP - SRCC Certification #2012011B

COMPONENTS	DESCRIPTION	QTY	SAMPLE SYSTEM COST	Price
SOLPAL L-E	Solpal 52 gal. preheat to electric water heater	1	System cost:	\$2,500 +
			Installation costs (labor, piping, ancillary components, permitting, etc.)	\$750 +
			Less 30% federal tax credit:	-\$975 -
			Less CA state rebate up to \$1,834	-\$912 -
MSRP SUBTOTAL \$2,500			Estimated incremental solar system cost for the homeowner:	\$1,363
			<i>Estimated annual energy savings: 1,690 kWh:</i>	<i>Estimate ROI: 5 years</i>

INTEGRAL COLLECTOR STORAGE SYSTEM WITH ELECTRIC BACKUP - SRCC Certification #2012011B

COMPONENTS	DESCRIPTION	QTY	SAMPLE SYSTEM COST	Price
SOLPAL L-E	Solpal 52 gal. preheat to electric water heater	1	System cost:	\$2,500 +
			Installation costs (labor, piping, ancillary components, permitting, etc.)	\$750 +
			Less 30% federal tax credit:	-\$975 -
			Less FL Utility rebate up to \$1,000	-\$1,000 -
MSRP SUBTOTAL \$2,500			Estimated incremental solar system cost for the homeowner:	\$1,275
			<i>Estimated annual energy savings: 1,420 kWh</i>	<i>Estimate ROI: 7 years</i>

SOLPAL INTEGRAL COLLECTOR STORAGE SYSTEM TECHNICAL DATA

TYPE	SOLPAL * L	SOLPAL * M
Total collector area	25.8 sqf	18.8 sqf
Dimensions (L x W x H)	86.0 x 43.3 x 8.3 in	86.0 x 31.5 x 8.3 in
Weight (empty, excluding fixing elements)	150 lbs	120 lb
Capacity	51.5 gallons	38.3 gallons
Insulation	1.18 in PUR foam panel	1.18 in PUR foam panel
Maximum operating temperature	212°F	212°F
Maximum operating pressure	58 psi	58 psi
Connections	2 x 3/4" male thread	2 x 3/4" male thread
Installation	Flat/Pitched roof	Flat/Pitched roof
Warranty	10 years	10 years

Note: Heliodyne takes no responsibility for the availability of any rebates or incentives.

THE GOBI COLLECTOR

By redesigning the frame and incorporating state-of-the-art components, the GOBI has a reduced profile with even better performance. And with three sizes and two absorber surface types to choose from, there is a GOBI collector for every type of solar water heating application.

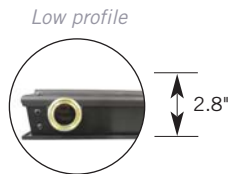

Features

- **Thinnest profile** – At just over 2.5", the GOBI has the slimmest profile in the United States. The redesigned frame offers you and the end user a streamlined, sleek look compared to bulky traditional flat plate collectors produced by most manufacturers.
- **Industry top performer** – New SRCC ratings certify that the GOBI now ranks among the best OG-100 certified collectors. The high energy output of the GOBI offers maximum performance from your SHW system.
- **Easiest to install** – Even though it's been completely redesigned, the GOBI retains the unique Dyn-O-Seal (DOS) union interconnection method. DOS unions come factory assembled and eliminate the time consuming task of soldering collectors together in an array.



SRCC OG-100 RATINGS (CLEAR DAY)

Category (Ti-Ta)	GOBI 406 001	GOBI 408 001	GOBI 410 001
Certification No.	2010115C	2010115D	2010115A
A (-9°F)	38.3	46.2	57.6
B (9°F)	34.9	42.0	52.4
C (36°F)	29.7	35.8	44.7
D (90°F)	20.3	24.5	30.7
E (144°F)	12.0	14.6	18.2

ABSORBER SURFACES

Blue Sputter coating – The most state of the art design, blue sputtered GOBIs offer optimal heat absorption which makes them suitable for any climate and region.

Black paint coating – An economical choice, black paint GOBIs are perfect for regions with ideal solar radiation such as Hawaii, Arizona or Florida.

PRODUCT CODE	GOBI 406 001	GOBI 408 001	GOBI 410 001	GOBI 406 002	GOBI 408 002	GOBI 410 002
Absorber Type	Blue Sputter	Blue Sputter	Blue Sputter	Black Paint	Black Paint	Black Paint
Height	81.5"	97.5"	121.5"	81.5"	97.5"	121.5"
Width	47.5"	47.5"	47.5"	47.5"	47.5"	47.5"
Thickness	2.8"	2.8"	2.8"	2.8"	2.8"	2.8"
Gross Surface Area	26.94 ft ²	32.32 ft ²	40.15 ft ²	26.94 ft ²	32.32 ft ²	40.15 ft ²
Absorber Surface Area	24.91 ft ²	29.94 ft ²	37.48 ft ²	24.91 ft ²	29.94 ft ²	37.48 ft ²
Dry Weight	74 lbs.	102 lbs.	127 lbs.	74 lbs.	102 lbs.	127 lbs.
Fluid Capacity	0.6 gal.	0.7 gal.	0.8 gal.	0.6 gal.	0.7 gal.	0.8 gal.

DYN-O-SEAL™ SYSTEM

The unique, proven Dyn-O-Seal™ (DOS) system utilizes non-solder unions that seal with a twist of the wrist, simplifying SHW system installation and saving you time on the job.

Risse Sleeve
Precut foam insulation with snap-on aluminum jacket to protect DOS connections.
ZZZZ 000 001

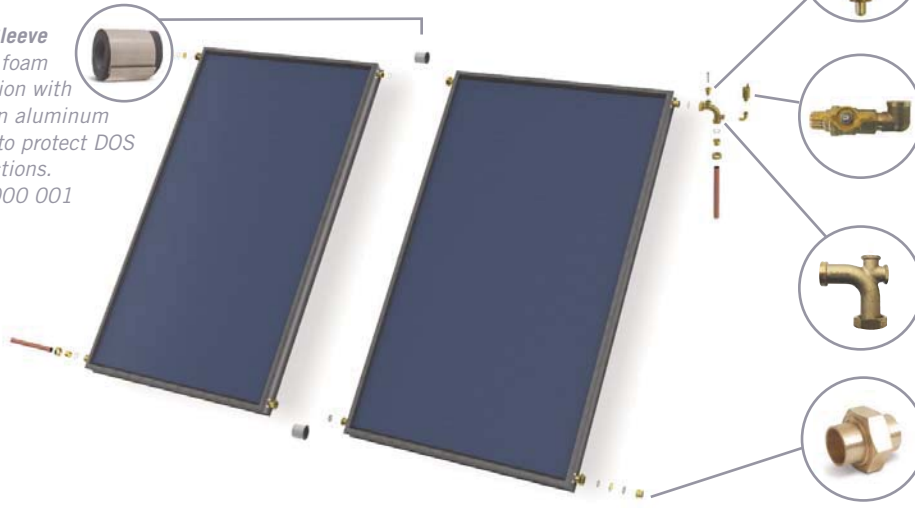

Temperature Sensor and Well
SENS 000 001
Sensor is inserted in the flow for optimal temperature reading.

Ball Valve Kit
ZZZZ 000 008
The air vent (with included elbow fitting) releases trapped air to maximize heat transfer efficiency.

Dyn-O-Seal Combo Fitting
ZZZZ 007 000
A unique fitting (with temperature sensor and air vent ports) that attaches directly onto the collector return header via DOS union.

Dyn-O-Seal Disc Union
ZZZZ 000 000
Non-solder union to interconnect collectors, connect supply/return lines and cap off unused headers. (2 required per vertical array)

DYN-O-SEAL™ ACCESSORIES

The Dyn-O-Seal Combo Fitting, Air Vent, and Ball Valve Kit allow for connecting an air vent and sensor, solderlessly, to hot return of GOBI collector array.

- Dyn-O-Seal Combo Fitting. Includes (2) ½” NPT ports, well sensor with ½” threaded well, and hex key
- Ball Valve Kit. Includes 420F-rated ball valve and brass ½” NPT elbow.
- 360F-rated Air Vent. For use only when purging air from collectors during commissioning. Ball valve allows for removal of air vent and elbow once system has reached optimal pressure (50 psi initially)



GOBI MOUNTING HARDWARE

Heliodyne collector mounting hardware is designed for use with the GOBI brand collector. A variety of kits are available to suit all roof types. Flush mount kits are generally used for roofs with a pitch of at least 15 degrees. Rack mount kits are primarily used for flat roofs. Collector rail kits are used in conjunction with both flush and rack mount kits.

SINGLE COLLECTOR KITS

SINGLE COLLECTOR FLUSH MOUNT

Product Code: FLSH 001 000

SIDE RACK KIT

Product Code: RACK 000 005 47" REAR LEGS

Product Code: RACK 000 006 30" REAR LEGS

SIDE RACK REAR FLANGE FOOT KIT

Product Code: RACK 000 007

COLLECTOR RAIL KITS

COLLECTOR RAIL KIT

Product Code: RAIL 001 000B For 1 collector

Product Code: RAIL 002 000B For 2 collectors

(Rail kits come with end caps)

RAIL SPLICE KIT

Product Code: RAIL 000 001 To combine rails

FLUSH-MOUNT COLLECTOR KITS

FLUSH MOUNT HANGER BOLT KIT

Product Code: FLSH 000 000

FLUSH MOUNT FLANGE FOOT KIT

Product Code: FLSH 000 001

TILE MOUNT KIT

Product Code: FLSH 000 002

RACK-MOUNT COLLECTOR KITS

RACK MOUNT STANDARD KIT (47"/4")

Product Code: RACK 000 001B

RACK MOUNT EXTENDED FRONT LEG KIT (47"/8")

Product Code: RACK 000 002B

RACK MOUNT EXTENDED REAR LEG KIT (67"/4")

Product Code: RACK 000 003B

UNISTRUT KITS

RACK MOUNT PIVOTING REAR FEET

Product Code: USTR 001 000

FRONT FEET FOR RAIL

Product Code: USTR 002 000

UNISTRUT LEG 47"

Product Code: USTR 000 001

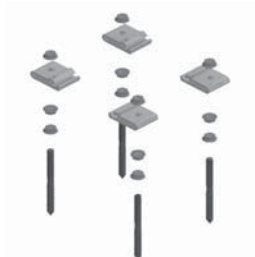

FLSH 001 000

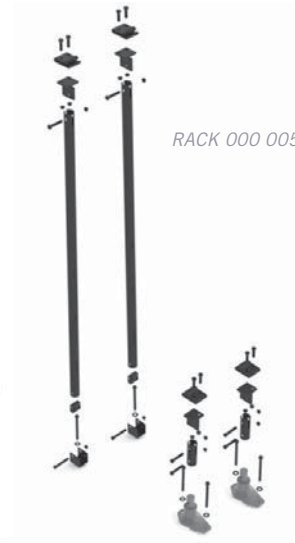

RACK 000 005



RAIL 002 000B

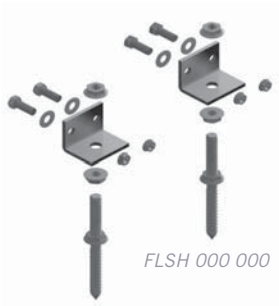

FLSH 000 000



FLSH 000 001



RACK 000 001B

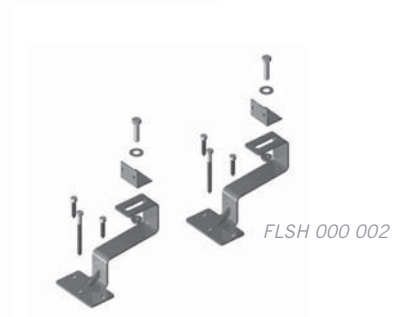

FLSH 000 002



USTR 001 000



USTR 002 000

USTR 000 001



GOBI MOUNTING HARDWARE (CONT.)

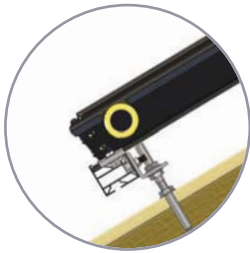

FLSH 000 000



FLSH 000 001

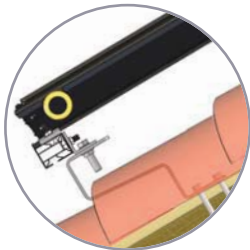

FLSH 000 002

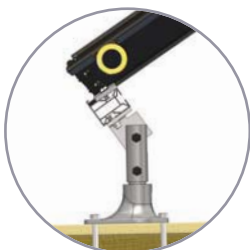

RACK 000 001B



USTR 002 000

FLUSH-MOUNT ASSEMBLY BILL OF MATERIALS

Use the table below to determine the number and type of mounting hardware kits necessary to flush-mount 2 to 8 collectors in an array. For example; if installing two collectors on a clay tile sloped roof, order one RAIL 002 000B and three FLSH 000 002.



COLLECTORS IN ARRAY	x2	x3	x4	x5	x6	x7	x8
RAIL 001 000B	0	1	0	1	0	1	0
RAIL 002 000B	1	1	2	2	3	3	4
RAIL 000 001	0	1	1	2	2	3	3
FLSH 000 000*	3	4	5	6	7	8	9
OR FLSH 000 001*	3	4	5	6	7	8	9
OR FLSH 000 002*	3	4	5	6	7	8	9

*It is the installer's responsibility, and that of the engineer of record, to verify that the roof structure is capable of handling the installation's point loads, and to verify the hardware does not experience loads greater than the maximum allowable as specified by Heliodyne. Refer to local codes for information on loading in your area.

RACK-MOUNT ASSEMBLY BILL OF MATERIALS

Use the table below to determine the number and type of mounting hardware kits necessary to rack-mount 2 to 8 collectors in an array. For example; if installing two collectors on a flat roof with a standard rack-mount kit, order one RAIL 002 000B and three RACK 000 001B.

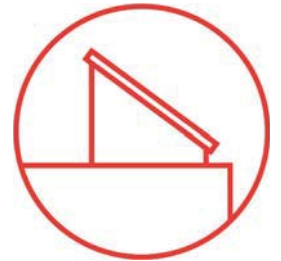

COLLECTORS IN ARRAY	x2	x3	x4	x5	x6	x7	x8
RAIL 001 000B	0	1	0	1	0	1	0
RAIL 002 000B	1	1	2	2	3	3	4
RAIL 000 001	0	1	1	2	2	3	3
RACK 000 001B*	3	4	5	6	7	8	9
OR RACK 000 002B*	3	4	5	6	7	8	9
OR RACK 000 003B*	3	4	5	6	7	8	9

UNISTRUT

COLLECTORS IN ARRAY	x2	x3	x4	x5	x6	x7	x8
USTR 001 000	3	4	5	6	7	8	9
USTR 002 000	2	3	4	5	6	7	8
USTR 000 001	3	4	5	6	7	8	9

HEAT-TRANSFER APPLIANCES: HELIO-FLO (OPEN LOOP)

A simplified design for open loop active systems, created with easy installation in mind. The Helio-Flo (HFLO) comes assembled with pump, standard or advanced controller, two sensors and two temperature gauges.

Features

- Efficient direct water circulation
- “Plug & Play” installation
- Sleek modern design
- Pro controller option
- Compact assembly

The HFLO comes assembled with:

- Delta-T, Delta-T Pro or Delta-T Pro Lite controller with collector/tank sensors (2)
- 2 combo valves
- Pump
- Easy tank/wall mounting bracket included



(Top-connect model shown)

Off-grid HFLO includes:



- DC Controller
- DC Pump
- 20W PV Panel



For Pro Controller upgrade, see page 27.

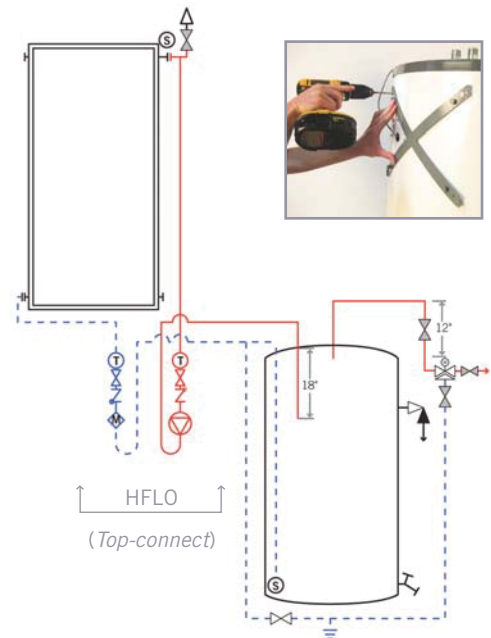

INCLUDES A TANK/WALL MOUNTING BRACKET

PRODUCT CODE	HFLO 016 000	HFLO 016 002	HFLO 048 011*	HFLO 016 100	HFLO 016 210
Controller	Std	Pro Lite	Pro	Std	Std
Voltage	110 AC	110 AC	240 AC	DC	240 AC
PV Panel included	-	-	-	Yes	-
Pipe Connection	Top	Top	Bottom	Top	Bottom
Energy Metering	-	Yes	Yes	-	Yes
Maximum Collector Area	96 ft ²	96 ft ²	320 ft ²	96 ft ²	96 ft ²

HEAT TRANSFER APPLIANCES: HELIO-PAK (CLOSED LOOP)

The Helio-Pak (HPAK) is an all-in-one heat transfer appliance specifically designed to simplify SHW systems and provide maximum heat transfer. The HPAK comes factory assembled with a standard (Delta-T) or Pro (Delta-T Pro or Delta-T Pro Lite) controller, and is wired with all the necessary components, making installation trouble-free. Because the HPAK utilizes an external heat exchanger, it can often be adapted to work with a preexisting hot water tank, thereby reducing costs.

Features

- Augmented heat exchanger surface promotes maximum heat generation
- Superior heat transfer via unique counterflow design
- Easy tank/wall mounting bracket included
- “Plug & Play” installation
- Viewable heat exchanger leak detection
- Several sizes available for differing loads

The HPAK comes assembled with:

- Double-wall external heat exchanger with leak detection
- Delta-T, Delta-T Pro or Delta-T Pro Lite controller with collector/tank sensors (2)
- Pressure relief valve
- Expansion tank
- Pressure gauge
- 2 combo valves, each with:
 - 1 check valve
 - 1 ball valve
 - 1 thermometer
- 2 pumps

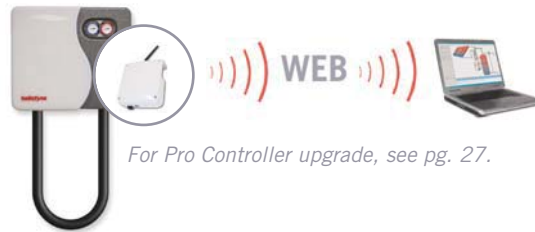

INCLUDES A TANK/WALL MOUNTING BRACKET

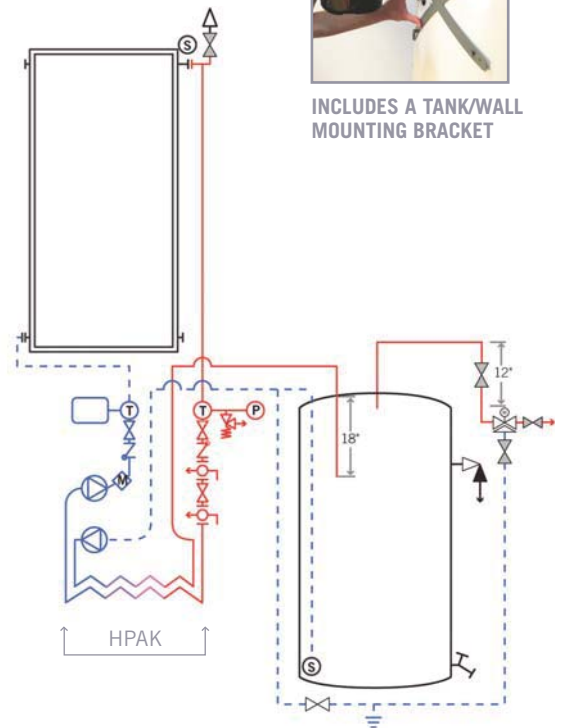

PRODUCT CODE	HPAK 016 000	HPAK 024 000	HPAK 032 000	HPAK 048 000	HPAK 016 002	HPAK 024 001	HPAK 032 001	HPAK 048 001
Maximum Collector Area	96 ft ²	160 ft ²	200 ft ²	320 ft ²	96 ft ²	160 ft ²	200 ft ²	320 ft ²
Controller	Std	Std	Std	Std	Pro Lite	Pro	Pro	Pro
Energy Metering	-	-	-	-	Yes	Yes	Yes	Yes
Wi-Fi Capable	-	-	-	-	Yes	Yes	Yes	Yes

HPAK 24, 32 and 48's are available with ethernet Pro controllers. Contact your sales rep for more information.

HEAT TRANSFER APPLIANCES: HELIO-PASS

The Helio-Pass (HPAS) is designed similarly to the HFLO, but slight modifications allow the HPAS to work with coil-in-tank heat exchangers. The HPAS serves as a closed loop heat transfer appliance, circulating solar fluid from the collectors through a tank-integrated coil heat exchanger located in the solar storage tank.

Features

- Sleek modern design
- Comes standard with Pro Lite controller
- “Plug & Play” installation
- Compact assembly
- Works with all major coil-in-tank heat exchanger brands

The Helio-Pass comes with:

- Delta-T Pro Lite controller with collector/tank sensors (2)
- Pressure relief valve
- Pressure gauge
- 2 combo valves
- Pump
- Expansion tank fitting
- Filling valve



INCLUDES A TANK/WALL MOUNTING BRACKET



heliodyne
SOLAR HOT WATER SOLUTIONS

The HPAS works in conjunction with solar tanks that utilize an integral coil heat exchanger such as the EcoStar series by Bradford White shown here.

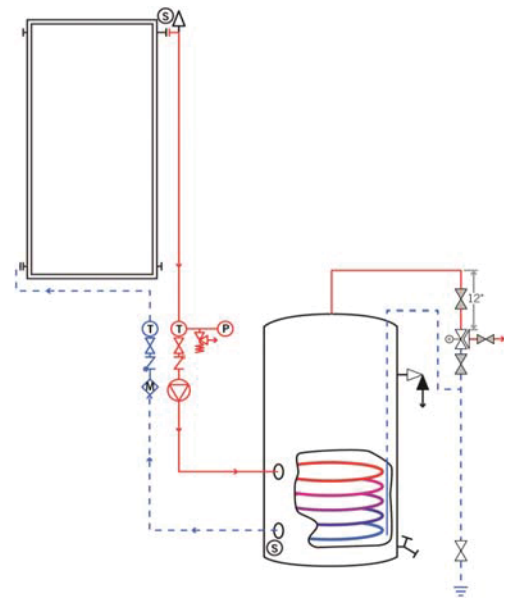
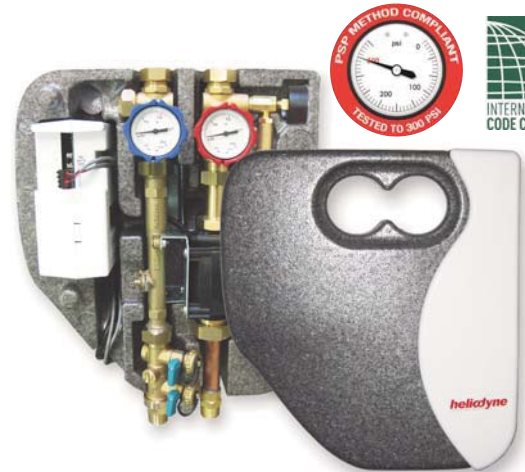

The HPAS comes standard with the Pro Lite controller for performance monitoring.

PRODUCT CODE	HPAS 016 012	HPAS 048 011
Max. suitable collector area	96 ft ²	320 ft ²
WiFi enabled	Yes	No
Controller	Pro Lite	Pro Ethernet

SOLAR FLEXTUBE

Flex tubes eliminate the time-consuming tasks of soldering and insulating your SHW system's pipe runs. It is made up of a corrugated stainless steel hose pre-insulated in Solar EPDM elastomeric foam. The foam itself is wrapped in a special UV-resistant skin. Flex tube should only be used with closed loop systems and a maximum pipe run of 200 ft.

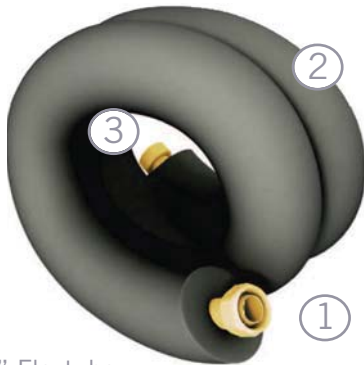

"ZFM" Flextube

- 1 - Gasket-free conical connection for connecting to VELUX solar collectors
- 2 - The flex tubes are pre-insulated to allow for quick and easy installation
- 3 - Adjustable length end for connection to solar pump stations and solar tanks using lock ring, nut and gasket

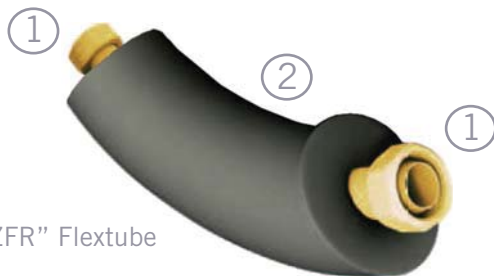

"ZFR" Flextube

VELUX Flexible Pipe Specifications

Max operating pressure	150 psi
External diameter, pipe	7/8"
Internal diameter, pipe	5/8"
Wall thickness, insulation	5/8"
Liquid volume	0.02 gal./ft.
Material, pipe	Stainless steel / AISI 316 TI
Material, insulation	Foam EPDM
Temperature limit, insulation	+ 350 °F to -40 °F
Insulation value	0.04 w/mK
R-Value	R-4

SRCC OG-300 COMPLIANT KITS

The Heliodyne OG-300 Valve Block is a complete pre-plumbed assembly providing all required BOS (Balance of System) components between the potable water connection and HPAK. This greatly reduces the installation time and ensures full SRCC OG-300 compliance.

Includes:

- Potable hot water connection
- Tempering valve
- Shutoff and bypass valves
- Fully insulated
- Labeling



BLOC 001 001 / BLOC 001 002

PRODUCT CODE	BLOC 001 001	BLOC 001 002	BLOC 001 003
Tank Configuration Type	Single Tank w/ Gas Backup	Single Tank w/ Electric	Dual Tank or Tankless Water Heater
Heliodyne Tank Compatibility	Gas Power Vent Models ¹ : U-2-TW-50T6FRN U-2-TW-65T6FRN M-2-TW-50T6BN, M-2-TW-65T6BN M-2-TW-75T6BN ²	MS65R6SS MS80R6SS MS120R6SS	MS65R6SS MS80R6SS MS120R6SS
	Gas Power Direct Vent Models ³ : PDX2-50T6FBN, PDX2-65T6FBN PDX2-75T6FBN		
	Dual Coil Heat Exchanger Backup: S-DC-DWZ-65R6SW S-DC-DEZ-75R6SW		
Description	Mixing valve block to comply with OG-300 on a single tank with integrated auxiliary heating	Mixing valve block to comply with OG-300 on a single tank with integrated auxiliary heating	Bypass valve block to be used in combination with BLOC 001 002 to comply with OG-300 on a dual tank or instantaneous water heating concept

¹Gas power vent draws combustion air from surroundings. ²Complies with California Lo No_x requirement.

³Power direct vent draws combustion air from outside.

COMMERCIAL SOLAR STATION (HCOM)

How It Works

The Heliodyne Commercial Stations (HCOM) are packaged closed loop heat transfer appliances that can accommodate large projects of up to 96 GOBI 410 collectors with a single module; still larger projects can be accommodated by combining modules in parallel. The HCOM operates on the same principles as our HPAK residential heat transfer appliances, with a few additional features for optimizing installation and performance, and lowering system maintenance.

Features

- “Plug & Play” installation
- Touch screen interface for configuration and at-a-glance monitoring (as an optional upgrade)
- Pro controller with temperature, flow, pressure and performance monitoring
- Integrated variable speed pumps for system energy optimization
- Circuit filter, flow gate, charging valves and component isolation valves preinstalled
- Novel integrated pressure relief, reclaim and refill system
- Cooling system for integrated electronics



Tank Guidelines for using HCOM

The HCOM works with atmospheric tanks provided that installation allows for a minimum 5 ft. height difference between pump inlet and tank top-water level. HCOMs with single-wall heat exchangers are used, and plumbed directly into the top and bottom of the tank. The water is heated through a coil-in-tank heat exchanger.

Pressurized tanks do not have any tank restrictions, and choosing the HCOM with a double-wall heat exchanger makes it possible to heat the water directly in the tank for increased system performance.

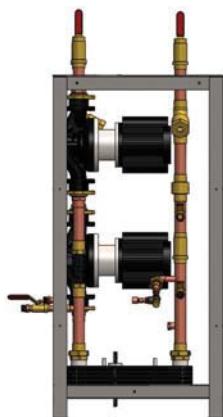

HCOM 180 000

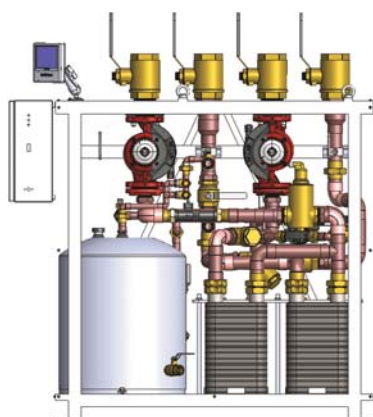

HCOM 275 000

HCOM 550 000

HCOM 825 000

HCOM TECHNICAL SPECIFICATIONS

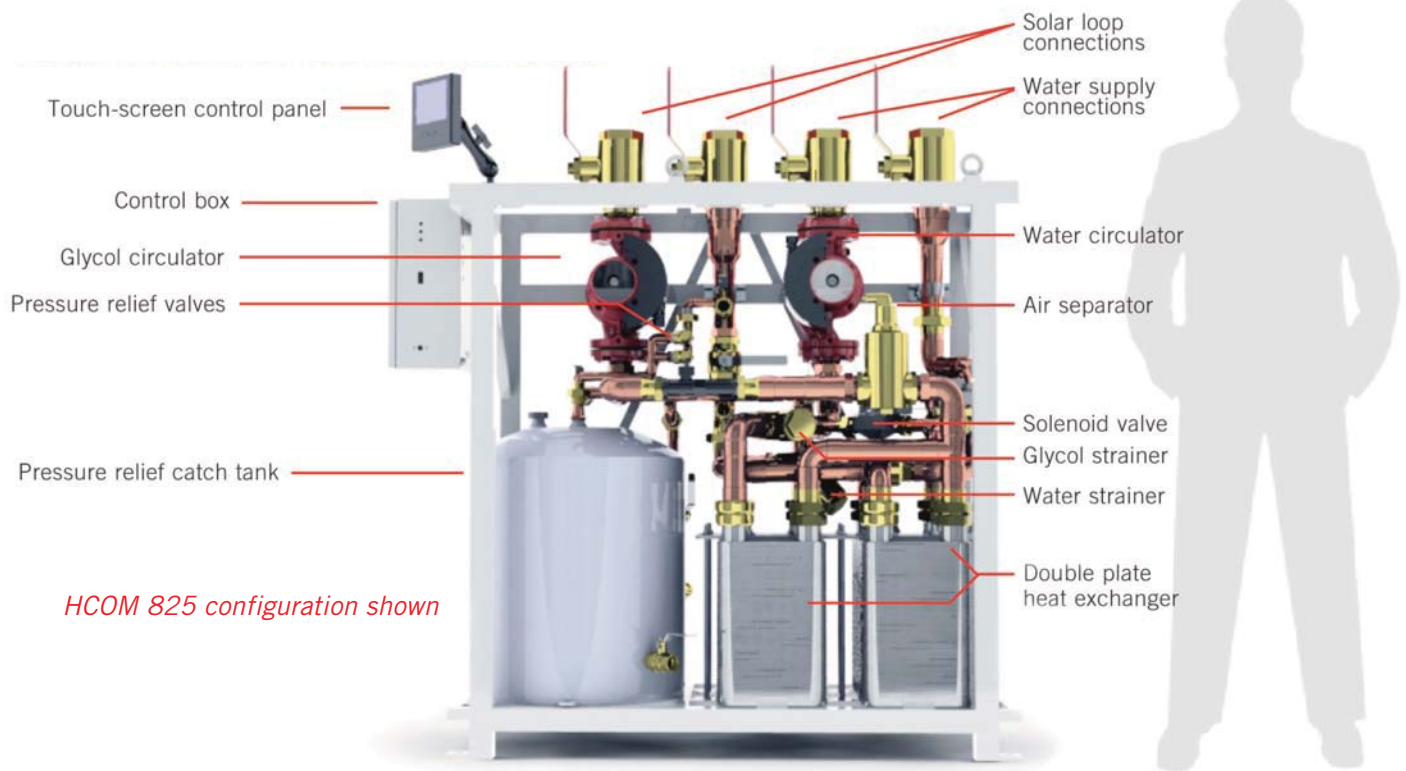

HCOM 825 configuration shown

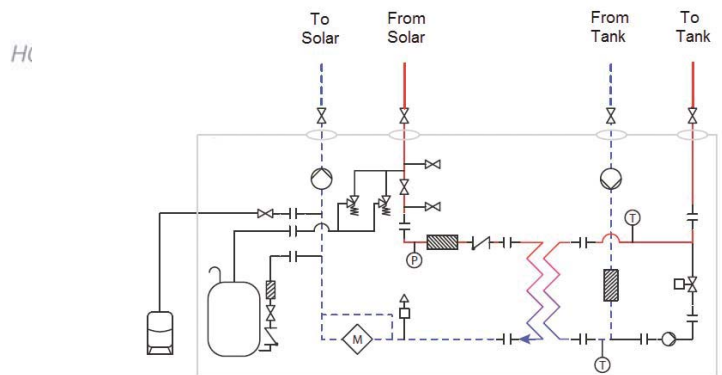
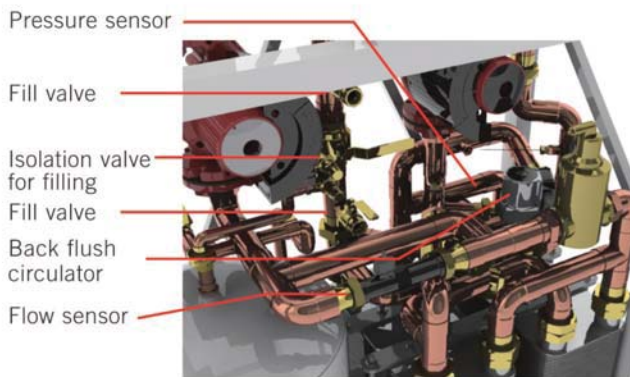

The HCOM hydraulic diagram

PRODUCT CODE	HCOM 180 000	HCOM 180 001	HCOM 275 000	HCOM 275 001	HCOM 550 000	HCOM 550 001	HCOM 825 000	HCOM 825 001
Max. Suitable Collector Area	960 ft ²	960 ft ²	1285 ft ²	1285 ft ²	2570 ft ²	2570 ft ²	3854 ft ²	3854 ft ²
Heat Exchanger	Single-wall	Double-wall	Single-wall	Double-wall	Single-wall	Double-wall	Single-wall	Double-wall
Dimensions	60"h 43"w 25"d	60"h 43"w 25"d	60"h 43"w 25"d	60"h 43"w 25"d	60"h 43"w 25"d	60"h 43"w 25"d	50"h 50"w 25"d	50"h 50"w 25"d
Supply and Return Connections	1.5" NPT	1.5" NPT	1.5" NPT	1.5" NPT	2" NPT	2" NPT	3" NPT	3" NPT
Supply Voltage	208/120 VAC 3-Phase	208/120 VAC 3-Phase	208/120 VAC 3-Phase	208/120 VAC 3-Phase	208/120 VAC 3-Phase	208/120 VAC 3-Phase	208/120 VAC 3-Phase	208/120 VAC 3-Phase
Suitable Application	DHW	DHW	DHW	DHW	DHW	DHW	DHW	DHW

A Commercial Solar Station has a 7-week inbound lead time.

CONTROL UNITS

DELTA-T

Specifically designed to regulate the operation of a solar heating system, the Delta-T monitors collector and storage temperatures and automatically turns pumps on or off when the right temperature is reached. The controller can also provide additional functions, such as system freeze-protection, by controlling recirculation and storage tank high-limit shut-off.

DELTA-T PRO CONTROLLERS

Pro controllers carry all the basic functions of the Delta-T, but include additional features such as more sensor inputs, relays, and, most importantly, energy metering and performance monitoring. All versions of the Pro controller come pre-installed with software allowing the controller to record and monitor energy data for the life of the system. This data can be uploaded to our website, where a user can monitor the system and make setting adjustments miles away from the actual installation.

Delta-T Pro Lite

- Programmable for open loop or closed loop DHW
- 2 thermistor sensors
- 2 relays

Delta-T Pro

- 5 program configurations available (open loop DHW, closed loop DHW, Pool, Space, Commercial)
- 5 thermistor sensors
- 3 relays
- Waterproof Delta-T Pro option for pool configurations
DLTA 000 004



Sensors not included.



Sensors not included.



Monitoring System Requirements

- DSL, cable or other broadband internet connection
- Open, WPA or QPA2 network authentication/ encryption Wi-Fi router
- Rich internet browser, e.g., Internet Explorer, Firefox, Safari
- T1 and T2 temperature sensors and flow sensor installed

REMOTE MONITORING!

- Hourly, daily, weekly and monthly performance graphs available to ensure your system is operating at peak performance
- Automatic email alerts reduce system down time



CONTROL UNITS (CONT.)

PRODUCT CODE	DLTA 000 000	DLTA 001 000	DLTA 002 000	DLTA 000 001	DLTA 000 002	DLTA 000 003	DLTA 000 004	DLTA 000 006
Model Type	Std	Std	Std	Pro	Pro	Pro Lite	Pro	Pro
Voltage	120	120	240	120*	120 or 240	120 or 240	120 or 240	120*
AC Cord	Yes	No	No	Yes	Yes	Yes	Yes	Yes
Temp Sensor Inputs	2	2	2	5	5	2	5	5
Relays	0	0	0	3	3	2	3	3
Waterproof	No	No	No	No	No	No	Yes	Yes
Energy Metering	No	No	No	Yes	Yes	Yes	Yes	Yes
Internal Flash Memory	-	-	-	36 Hours	30 Days	24 Hours	30 Days	36 Hours
Program Settings	OL DHW CL DHW	OL DHW CL DHW	OL DHW CL DHW	OL DHW CL DHW Pool, Space, Commercial	OL DHW CL DHW Pool, Space, Commercial	OL DHW CL DHW	OL DHW CL DHW Pool, Space, Commercial	OL DHW CL DHW Pool, Space, Commercial
Network Connection	-	-	-	Ethernet	Wi-Fi	Wi-Fi	Wi-Fi	Ethernet
Vortex Flow Sensor Input	-	-	-	Yes	Yes	Yes	Yes	Yes
Relative Pressure Sensor	-	-	-	Yes	Yes	Yes	Yes	Yes
Relay 2 Timer Setting	-	-	-	-	-	Yes	-	-
Relay 3 Timer Setting	-	-	-	Yes	Yes	-	Yes	Yes
Single Bottom Fired Gas Tank w/ electric ignition function	-	-	-	Yes	Yes	Yes	Yes	Yes
Electrical Circuit Monitoring	-	-	-	Yes	Yes	Yes	Yes	Yes
Pyrometer Input	-	-	-	Yes	Yes	Yes	Yes	Yes

*240 VAC available upon request.

HEAT EXCHANGERS, STORAGE TANKS AND ACCESSORIES

PLATE HEAT EXCHANGERS Up to a 5-week inbound lead time.

Plate heat exchangers are suitable for larger pool and commercial systems and are available in single-wall or double-wall configurations. Note: Solar systems using plate heat exchangers should not be designed with a solar fraction higher than 40%.



PRODUCT CODE	SHEX 050 001	SHEX 100 001	SHEX 140 001	SHEX 200 001	DHEX 110 001	DHEX 198 001	PHEX 020 000	PHEX 036 000	PHEX 060 000
Type	Single-wall	Single-wall	Single-wall	Single-wall	Double-wall	Double-wall	Pool	Pool	Pool
Alloy	Stainless Steel	Stainless Steel	Stainless Steel	Stainless Steel	Stainless Steel	Stainless Steel	254SMO SS	254SMO SS	254SMO SS
Max. Suitable Collector Area	1285 ft ²	2570 ft ²	3855 ft ²	5782 ft ²	1285 ft ²	2570 ft ²	1285 ft ²	2570 ft ²	2782 ft ²

Pool heat exchangers are suitable for chlorine pools only—not saltwater pools. Call your sales representative for more information.

TANKS

Heliodyne tanks have been specifically designed for use with SHW systems. Design features such as built-in sensor ports and solar in/out connections minimize installation time and optimize performance compared to using traditional off-the-shelf water heaters.

HELIO-TANK WITH SIDE PORTS

HSTG 119 000 119 gallon tank

Features

- Eight 2" ports for interconnecting multiple tanks
- Glass-lined tank
- Twin 3/4" magnesium anode rods
- Factory installed brass drain valve
- 2" non-CFC foam insulation (R-16)
- Steel external jacket
- Built-in sensor ports for top & bottom temp. sensors
- 2 separate connections for solar heating



TANK CONNECTOR KIT

CTOR 000 000

- Set of 4 stainless steel connectors used to plumb multiple 119-gallon tanks in parallel.
- Riser sleeve snap insulator jackets for 2.5" connectors

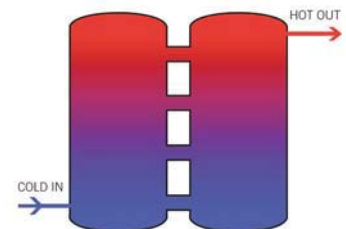

Tanks with electrical backup heating elements are also available from Heliodyne. Call your sales representative for more information.

ROOF-MOUNT KITS

CLIP KITS

CLIP 000 000B

For use with Heliodyne brand rails - 4 clips per kit



CLIP 001 000

For use with Unistrut rails - 1 clip per kit

WAKAFLEX ROOF FLASHING

WAKA 033 000 Comes in 33 ft. roll



ROOF-MOUNT KITS

RMAS 001 000

Single collector Flush-mount Kit for asphalt shingles.

Includes: Four - 3/8" lag bolts with flashings and collector clips.

For pipe connection, it includes 2 - DOS Combo fittings used with GOBI collectors.

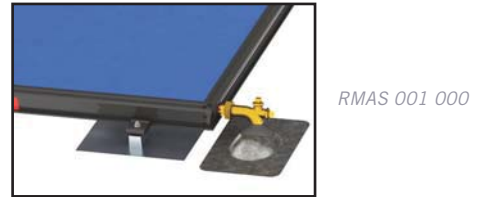

RMAS 002 000

Dual collector Flush-mount Kit for asphalt shingles. Same as RMAS 001 000 except that it includes eight - lag bolts is fitted with 2 brackets for RAIL 002 000B (rail not included).

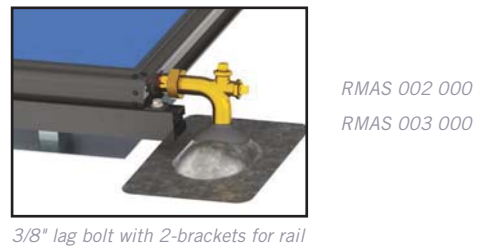

RMAS 003 000

Collector Flush-mount Kit as above for 3 collectors.

UNISTRUT KITS

USTR 001 000

Pivoting rear feet for Unistrut rails for rack-mount.

Order $n + 1$ sets (n = number of collectors in array).



USTR 002 000

Pivoting front feet for Unistrut rail. Order $n + 1$ sets (n = number of collectors in array).



PARTS & ACCESSORIES

SENSORS & METERS

SENSOR 10K ohm

SENS 000 001 Tank temperature sensor

SENS 001 001 Collector sensor for sensor well

SENSOR WIRE

SENS 000 002 Stranded vinyl jacket, 2-lead per 100 ft.

FLOW SENSOR

FLOS 010 000 For up to 10.5 gal/min

FLOS 026 000 For up to 26 gal/min

FLOS 053 000 For up to 53 gal/min

FLOS 106 000 For up to 106 gal/min

PRESSURE SENSOR

PRSS 150 000 For up to 150 psi

FLOW METER (POLYSULFONE)

FLOM 005 000 Monitors up to 5 gal. system measurements

FLOM 020 000 Monitors up to 20 gal. system measurements

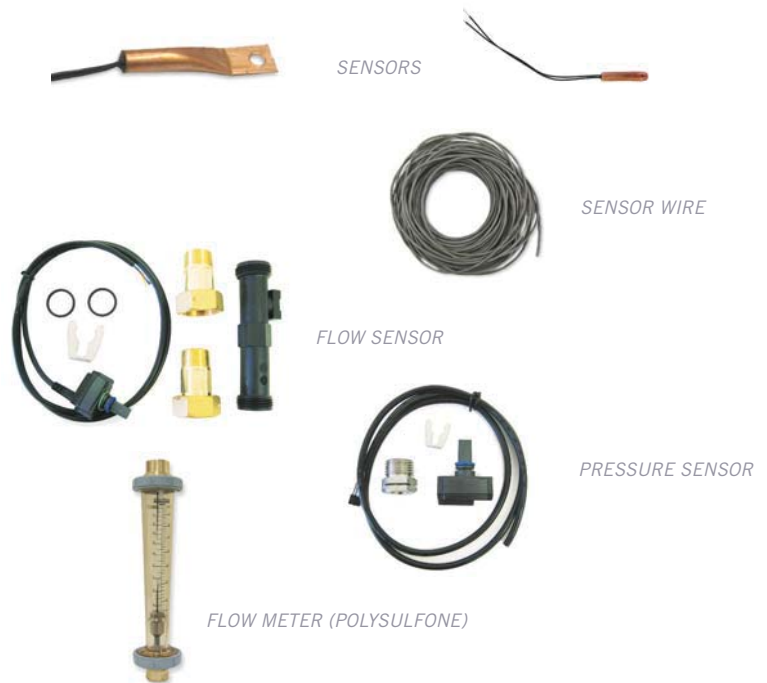

VALVES & FITTINGS

DYN-O-SEAL™ (DOS) DISC UNIONS

Non-solder unions for connecting piping to GOBI collectors

ZZZZ 000 000 1" (2 required per vertical array)

ZZZZ 001 000 3/4" (2 required per vertical array)

ZZZZ 002 000 1/2" (2 required per vertical array)

SOLAR FLEXTUBE DOS UNIONS

Non-solder unions for connecting to solar flextube

ZZZZ 003 000 DOS flanged union w/ disc

ZZZZ 004 000 DOS threaded union w/ disc

ZZZZ 005 000 DOS compression union (2 included)

ZZZZ 006 000 DOS extension union

DYN-O-SEAL™ COMBO FITTING

ZZZZ 007 000 Includes sensor well and sensor

SOLAR CHECK VALVE

ZZZZ 000 002 3/4" S

TEMPERING (MIXING) VALVE

ZZZZ 000 003 Watts 3/4" S, 100°F–180°F



PARTS & ACCESSORIES (CONT.)

THREAD BRASS "DIELECTRIC" UNION

ZZZZ 000 004 1" C x 3/4"



THREAD BRASS "DIELECTRIC" UNION

DOLE DRIBBLE VALVE

Anti-freeze protection valve for open loop systems

ZZZZ 000 007



DOLE DRIBBLE VALVE

DIVERTAFLO

ZZZZ 000 005 4-port 3/4" S Taras Tank bypass valve



DIVERTAFLO

AIR VENT

ZZZZ 000 009 Vent used to release trapped air



AIR VENT

BALL VALVE KIT FOR AIR VENT

ZZZZ 000 008 Includes ball valve and 1/2" elbow fitting.

For use with Dyn-O-Seal combo fitting



BALL VALVE KIT

PIPING & CONNECTIONS

SOLAR FLEXTUBES

ZFM 015 49.2' length

ZFM 020 65.6' length

ZFM 025 82.0' length

Pre-Insulated 3/4" corrugated stainless steel flextube

307438 - 3/4" Flextube to 3/4" Copper pipe adapter



ZFM FLEXTUBE



FLEXTUBE - CU Adapter

RHINO FLEXTUBES

RFLX 015 000 15" lengths

RFLX 024 000 24" lengths



RHINO FLEXTUBES

EXPANSION TANK

EXPT 002 000 2-gallon tank

EXPT 005 000 5-gallon tank



EXPANSION TANK

WALL-MOUNT BRACKET FOR TANK

EXPT 006 000



WALL-MOUNT BRACKET FOR TANK

OTHER ACCESSORIES

DYN-O-FLO HIGH TEMP. TRANSFER FLUID CONCENTRATE

DFLO 001 004 Box of four gallons

DFLO 001 055 55 gal. drum, 23" diam. x 34" h.



DYN-O-FLO HIGH TEMP. TRANSFER FLUID CONCENTRATE

RISSE SLEEVE

ZZZZ 000 001

Snap-insulate aluminum jacket over 2.5" tank connector kits



RISSE SLEEVE

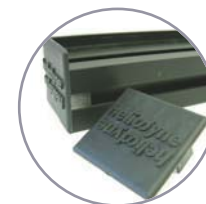

END CAPS FOR COLLECTOR RAILS

END CAPS FOR COLLECTOR RAILS

ZZZZ 000 010 4 caps for mounting rails

TERMS & CONDITIONS

1 . General Information

These terms and conditions of business are an integrated part of every product and service offered by HELIODYNE and every purchasing agreement signed with it. They apply starting 3/1/2008. General terms and conditions of business, regardless of the type, that conflict with these terms and conditions of business shall be considered invalid and of no legal force.

2 . Products and Services

Our range, descriptions, and specifications of products are not binding. We reserve the right to make technical changes to products due to technical developments. All technical documents remain the intellectual property of the contractor.

3 . Prices

Unless otherwise agreed in writing, prices are net prices ex works, not including packaging and not including discounts. Prices are merely suggested prices, approximated at the time of signing the agreement. If material costs increase between the time the agreement is signed and performed regardless of reason of the parity commission, prices in consideration shall be increased accordingly, unless fewer than 3 months have elapsed between the signing of the agreement and performance.

4 . Time for Performance and Deadlines

Delivery dates are never binding unless a fixed date is expressly agreed. If a change to an agreement is agreed, HELIODYNE is entitled to set a new delivery date. HELIODYNE is not liable for delivery delays that are not due to our fault or negligence. In this case, the contractor waives the right to terminate the agreement and to assert claims to damages. In the case of delay in performance of service caused by the contractor or suspension, the contractor must cover all additional costs caused by the delay or suspension, and HELIODYNE can cause our services and costs to become due using partial invoices.

5 . Payment

Unless otherwise agreed, goods shall be delivered only cash on delivery or on prepayment net without discount. Checks and bills of exchange will only be accepted if agreed separately and only on account of payment, not instead of performance. Recovery and discount charges shall be borne by the contractor. HELIODYNE can decline payments offered in the form of checks or bills of exchange without providing a reason. Set-off or withholding payment for any reason whatsoever by the client is prohibited unless expressly agreed. Payments must be made in full to one of our accounts or to a person with the authority to collect. If the credit period is exceeded, if payment is received late or if deadlines are not met, HELIODYNE is entitled to assess late charges in the amount of 5% above the rate set by the Bank of America as its prime rate of interest. In the case of default, the contractor must pay collection fees, intervention costs and attorney fees in addition to late fees. Warranty claims asserted by the client do not entitle the client to withhold agreed payments.

6 . Failure to Meet Due Dates

If the client defaults on a payment that is part of an agreement or a part of a payment for over 2 weeks, HELIODYNE is entitled to call due the entire remaining purchase price (remaining invoice amount) immediately. Further, the entire remaining balance becomes due if execution of the property fails, forced sale of properties or sequestration is authorized, or if the credit rating or credit worthiness declines in any other form. Failure to meet due dates shall entitle HELIODYNE to terminate the agreement.

7 . Shipping and Transfer, Exchange, Reversed Transaction

The client must inspect and accept goods immediately after receiving goods at the agreed transfer site or have goods inspected and accepted by persons authorized to do so, in such manner. If the contractor does not inspect the goods, the object of purchase shall be deemed duly delivered and accepted. Shipping always takes place, even in the case of freight-paid shipping, at the contractor's cost and risk. HELIODYNE's contractual obligations are fulfilled upon transfer of the goods ordered by the client to the carrier, and risk of loss is transferred to the client. The agreement can only be terminated or modified despite proper performance by HELIODYNE with the consent of HELIODYNE. In all cases, the client must pay the full purchase price including costs (delivery, etc.) or —at the discretion of HELIODYNE— a lump sum that covers the generally expected costs, but not less than 15% of the purchase price. Goods must be returned to HELIODYNE in undamaged condition including the original packaging. HELIODYNE shall not agree to replace goods later than three months after the date they were delivered. Special goods (not stock goods) shall not be replaced.

8 . Retention of Title

8.1. HELIODYNE retains the title to goods it supplies until outstanding debts resulting from the business relationship are paid in full. These goods may only be sold in a normal business transaction as long as the client is not in default of payment with HELIODYNE.

8.2. In the case of resale, the following provisions apply:

– In signing the agreement, the contractor already cedes to HELIODYNE outstanding debts resulting from the sale.

– On request, the client must inform HELIODYNE of transfer to a third-party purchaser and give HELIODYNE all documents and information required for asserting ceded debts.

– If reserved goods or outstanding debts ceded to HELIODYNE are pledged, HELIODYNE must be notified of all circumstances that are required for asserting its claims.

8.3. The power of the client to sell reserved goods in a proper business transaction ends at the latest with the client's cessation of payment or if insolvency proceedings regarding the client or the client's property are filed. In this case, the client must deliver the reserved goods to HELIODYNE at HELIODYNE's first request. Demanding return of reserved goods does not equal termination of the purchase agreement.

8.4. Pledging or assigning reserved goods by way of security or transferring assigned debts is not permitted.

8.5. HELIODYNE shall release securities pledged to HELIODYNE according to the above provisions at its discretion if the value of the securities exceeds the debt to be secured by 10%, taking into account value added by the customer.

8.6. HELIODYNE must be informed of levies of attachment immediately by the execution creditor.

8.7. The client is required to send HELIODYNE a statement on goods that are still under retention of title and a statement of debts to third-party debtors in addition to credit notes as soon as the client has stopped payment, meaning immediately after giving notice that the client is stopping payments.

9 . Warranty

9.1. HELIODYNE shall provide a one-year warranty for defects in compliance with the purchased goods delivered on 3/1/2008 as follows: Objects are warranted at HELIODYNE's discretion by repair of the object of purchase or replacement of defective parts, exchange or reduction of price. The right of the contractor to convert objects is ceded by common consent. Replaced parts become the property of HELIODYNE. Wages and costs spent on installation and disassembly must be covered by the client. This provision similarly applies to all warranty agreements. It is at HELIODYNE's discretion to replace defective goods with similar, faultless goods. In this case, any rights to cancel the agreement cease. The client expressly waives the right for it and its legal successors to assert claims for damages or loss of profit (including without limitation special, indirect, loss of use, contingent, or consequential damages) due to defects or nonconformity in the purchased good. The warranty set forth above constitutes the sole and exclusive remedy against HELIODYNE for the furnishing of any nonconforming or defective goods. THE ABOVE WARRANTY IS EXPRESSLY IN LIEU OF ALL OTHER WARRANTIES, EXPRESS OR IMPLIED, INCLUDING WITHOUT LIMITATION ANY WARRANTY AS TO MERCHANTABILITY OR FITNESS FOR A PARTICULAR USE OR PURPOSE. Damage resulting from improper or negligent treatment is excluded from the warranty. Claims on warranty will only be admitted and considered if they are announced in writing immediately after the defect was first noticed. Oral communication or communication by telephone are not sufficient.

9.2. For collectors (except broken glass and collector accessories, e.g., sheet metal edgings), storage tanks (except attached components), and heating appliances, HELIODYNE replaces materials that demonstrably fail to meet one of the requirements of the ASHRAE standard 93-77 at no charge: ten years for collectors, five years for heating appliances (three years for electronics) and five years for storage tanks, from the date of the invoice issued by the company HELIODYNE. HELIODYNE is not liable, however, for damage caused by mechanical stress and/or changes caused by weather-related influences. Minor variations in color and/or damage to the surface that have no effect on the function of the collector are also not covered in the warranty. The warranty excludes damage caused by force majeure and malfunction that are due to improper assembly, and/or product installation. HELIODYNE is not liable for possible costs resulting from defects. In order for HELIODYNE to accept liability:

– Installation must have been carried out by a licensed specialized company (heating contractor or plumber) following the version of installation instructions in force;

– HELIODYNE or its representative was given the opportunity to check complaints on site immediately after any defect occurred;

– Confirmation exists that the system was commissioned properly and that the system was checked and maintenance was performed annually by a specialized company licensed for this purpose. The warranty agreed by HELIODYNE is only valid for their clients.

10 . Place of Performance and Jurisdiction

The place of performance for delivery and payment is Richmond, California. The contract shall be in all respects constructed and governed by the laws of the State of California. Any dispute arising hereunder shall be settled in accordance with California law, and the client consents to jurisdiction in the State of California.

Your Authorized Heliodyne Distributor:



US © 2014 Heliodyne, Inc. • Heliodyne and Excellence by Design are registered trademarks of Heliodyne, Inc.

Heliodyne, Inc. • 4910 Seaport Avenue • Richmond, CA 94804
T: 1.888.878.8750 or 510.237.9614 • F: 510.237.7018
Information & Support: info@heliodyne.com
Sales Inquiries: sales@heliodyne.com
www.heliodyne.com