

Installation
Operation &
Maintenance

JM
series

Condensate
neutralizing
tubes

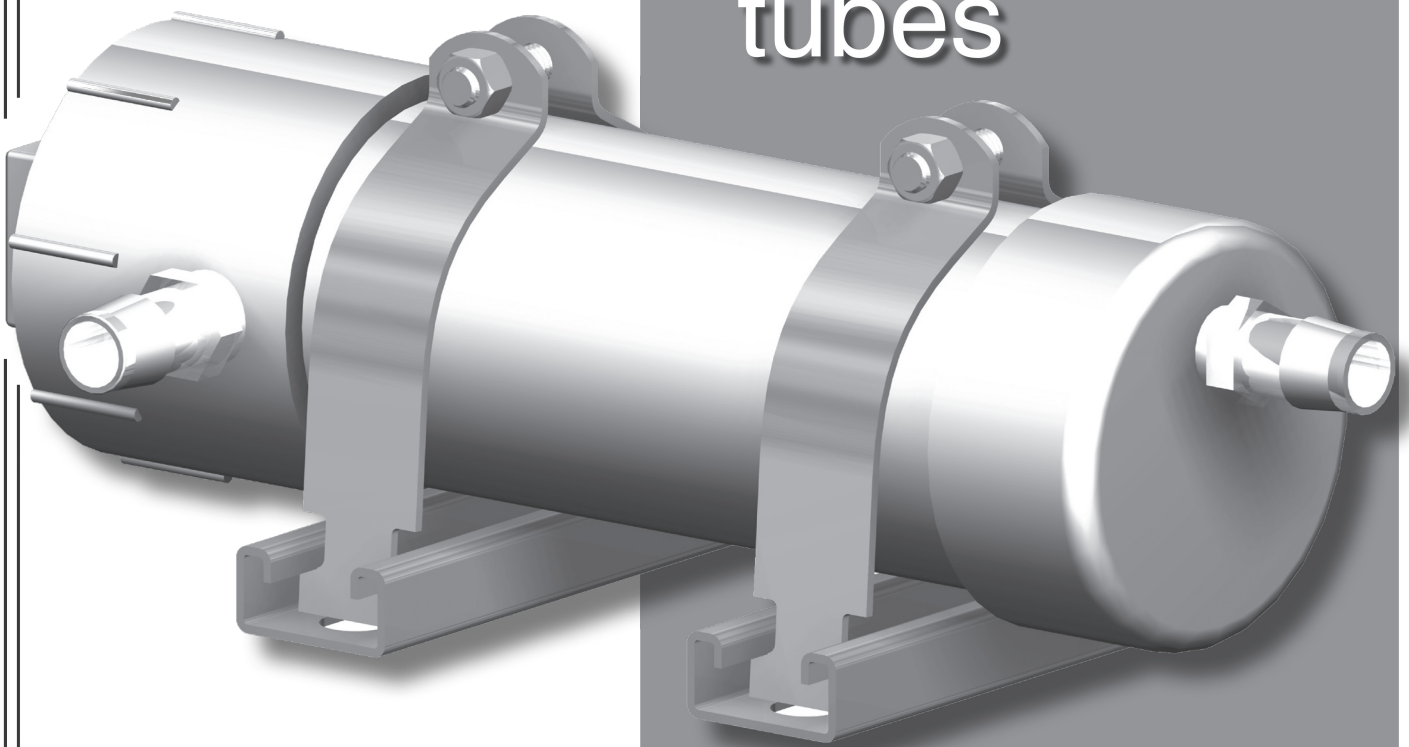

**Models
JM-6 to JM-50**

JJM Boiler Works

20 Hillside Meadows Drive
Southampton, MA 01073

Phone 413-527-1893
web: www.jjmboilerworks.com



Overview

Read before proceeding . . .

⚠️ WARNING Failure to comply with the following guidelines could result in severe personal injury, death or substantial property damage.

Neutralizer and lines must be wet

- **Before operating the boiler or furnace, fill the JM tube and traps with tap water. NEVER operate with tubes or P-traps dry.**

Application restrictions

- Flue gas condensing boilers, furnaces, and flue pipe condensate drains only.
- DO NOT exhaust flue gases through JM tubes, they are not rated for boiler or furnace flue gases. Operating JM tubes as exhaust vents can cause injury or death from carbon monoxide.
- Gas traps must be installed between the boiler, vent drains, and furnace condensate outlet and the inlet of all JM tubes.
- JM tubes must be installed below system P-traps, boiler, furnace, and breeching condensate drains.

Combined piping options

Flue pipe condensate drains

- Boiler/furnace condensate drain and flue condensate drain can be common piped to a neutralizer tube ONLY if the boiler/furnace is individually vented (NOT connected to a common vent system). Also, the flue pipe must be terminated so rain water cannot enter the flue pipe.
- DO NOT connect any flue pipe condensate line to a neutralizer tube that serves more than one boiler.

Boiler/furnace condensate line common piping

- DO NOT combine vent condensate drain lines and boiler/furnace condensate lines if appliances are common vented. Use a separate JM tube for each application. For individually-vented appliances, vent and condensate drain lines can be combined.

Recharge tubes regularly

- Tubes should be recharged when pH level moves below 6. The pH should be checked regularly (at least twice during the first year of operation) to determine the required recharging schedule.
- This may require recharging as often as twice per year for high-usage systems, such as boiler systems equipped with indirect water heaters.
- Boiler/furnace applications for space heating only (no DHW) may require recharging only once per year.

What is pH?

The pH measurement of a fluid is an indicator of the acidity or alkalinity. Neutral fluids have pH of 7.0. Acid fluids have pH below 7. And alkaline fluids have pH above 7 (up to 14). The pH can be easily measured using litmus paper.

Condensate pH from condensing boilers and furnaces is acidic. The condensate pH needs to be increased (made less acidic) to prevent possible damage to cast iron soil pipe, ABS pipe, septic tanks, plants, wastewater treatment plants and other materials handling waste water.

JM-series condensate neutralizing tubes increase pH (reduce acidity).

JM-series commercial flue-side condensate neutralizing tanks are designed to raise the pH level of the condensate discharged by high-efficiency boilers and warm air furnaces.

Each increase of 1.0 in pH is a 10-times decrease in acidity. The pH of condensate is increased by approximately 1.0 to 3.0 after passing through NB neutralizing tanks. (This is a reduction in acid concentration of from 10 to 1000 times.)

Applying JM-series neutralizing tubes

Condensate can be collected from flueways and boiler/furnace condensate trap outlets. See WARNING section at left for guidelines on application.

Match neutralizing tubes to boiler/furnace ratings. Use multiple tubes if needed to handle the load. Consider using the next larger size neutralizing tube for boiler systems with domestic hot water heating.

Locate the neutralizing tube below the condensate connection and slightly above the floor drain or inlet to a condensate pump reservoir (if used).

Follow the guidelines in this manual, the boiler/furnace manual and all applicable local codes when installing, using and maintaining JM-series condensate neutralizing tubes.

Installation sequence

1. Securely fasten the two mounting clamps (item M) to floor or wall (recommended spacing is 6½ inches apart).
2. Pull clamps apart and insert JM tube — pay attention to INLET and OUTLET markings on the tube. Close clamps tightly (using slight pressure with pliers if needed).
3. Connect plastic tubes or PVC piping from appliance or breeching drains to P-traps and then from P-trap outlet to either one of the two JM tube inlets.
4. Connect the JM tube outlet to house drain or condensate pump.
5. Use Teflon tape on all threaded plastic fittings.
6. NOTE — Always contact the local authority in regards to any requirements concerning flue gas condensate handling codes.

Installation

Figure 1 JM-series condensate neutralizing tubes — features and dimensions

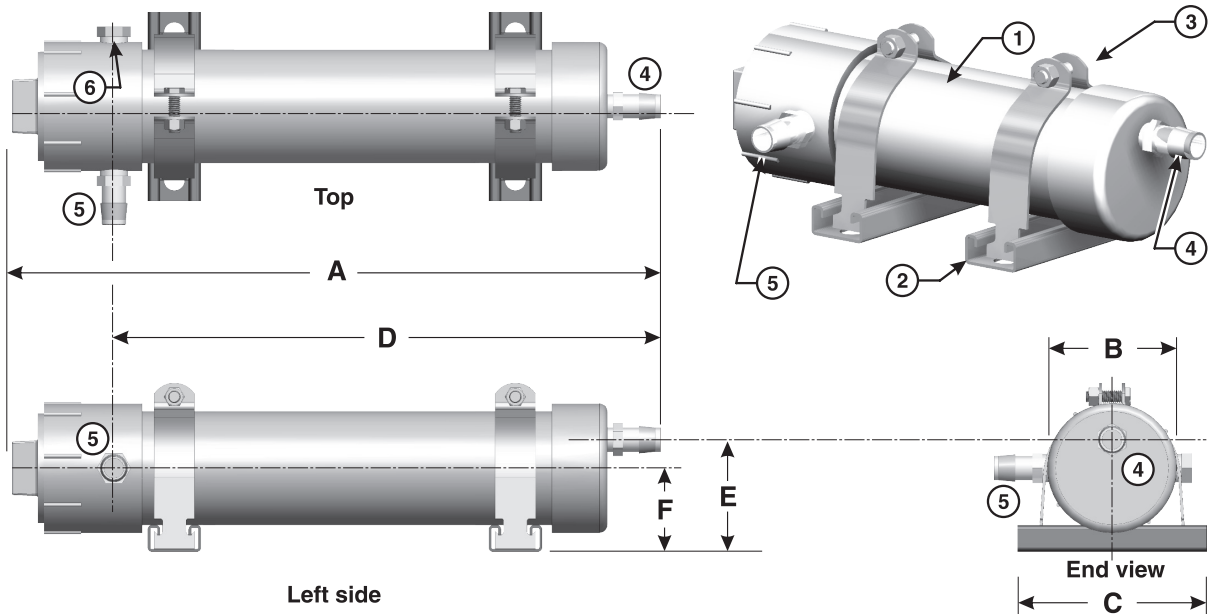

RATINGS & DIMENSIONS (in inches)								
Model	MBH	GPH	A	B	C	D	E	F
JM-6	600	6	14 ¼	4	6	10 ¾	3 ½	2 ½
JM-10	1,000	10	19	4	6	16 ⅛	3 ½	2 ½
JM-20	2,000	20	19 ½	5	6	16 ⅛	4 ½	3 ⅛
JM-30	3,000	30	24 ½	5	6	21	4 ½	3 ⅛
JM-40	4,000	40	22 ½	7 ⅞	8	19	7 ½	4 ½
JM-50	5,000	50	28 ½	7 ⅞	8	24	7 ½	4 ½

Item	Description	
1	PVC tubing filled with ½" and ¾" aggregate calcium carbonate	
2	Channel strut mounts	
3	Galvanized strut clamps, bolts and nuts	
4	Condensate outlet hose barb fitting	JM-6 to -10: ¾" hose barb x ½" NPT JM-20 to -30: ¾" hose barb x ¾" NPT
5	Condensate inlet hose barb fitting	JM-40 to -50: 1" hose barb x ¾" NPT
6	Plugged — alternate location for condensate inlet hose barb fitting	

Figure 2 JM-series tube with floor drain, typical

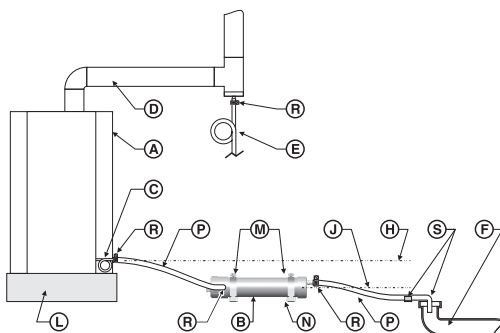

- A** Condensing boiler or furnace
- B** JM condensate neutralizing tube (or multiple tubes piped in parallel)
- C** Boiler/furnace condensate trap connection
- D** Boiler/furnace vent
- E** Vent condensate trap, when used — Install a trap as shown. Connect the tubing to a separate JM tube if appliances are common vented. For individually-vented appliances, the vent condensate drain can be connected to the appliance condensate drain line.
- F** Floor drain or sump
- G** Condensate pump
- H** Bottom of boiler/furnace condensate outlet — MUST be ABOVE condensate pump inlet connection
- J** Bottom of JM tube condensate outlet
- L** Mounting pad or structural platform, when required to elevate boiler condensate drain as needed
- M** Mounting clamps
- N** Mounting clamps must be secured to the mounting surface
- P** Plastic tubing or PVC pipe — When using PVC pipe, remove the JM inlet and outlet hose barb fittings and replace with threaded PVC fittings. Include unions in the piping to allow removal of the JM tube for inspection and service. — Secure pipe or tubing in place. — Protect with a shield if necessary if routed through traffic areas.
- R** Use hose clamps at all connections when using plastic tubing.
- S** Condensate drain termination at floor drain (or condensate pump reservoir inlet) — secure in place with clamps. — Follow instructions for condensate pump.
- T** Elevate the JM tube on a structural base if necessary for the outlet to be raised.
- U** Route condensate discharge line from to appropriate drain location.

Figure 3 JM-series tube with condensate pump, typical

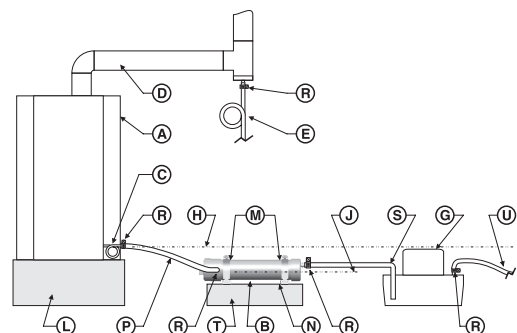

- M** Mounting clamps
- N** Mounting clamps must be secured to the mounting surface
- P** Plastic tubing or PVC pipe — When using PVC pipe, remove the JM inlet and outlet hose barb fittings and replace with threaded PVC fittings. Include unions in the piping to allow removal of the JM tube for inspection and service. — Secure pipe or tubing in place. — Protect with a shield if necessary if routed through traffic areas.
- R** Use hose clamps at all connections when using plastic tubing.
- S** Condensate drain termination at floor drain (or condensate pump reservoir inlet) — secure in place with clamps. — Follow instructions for condensate pump.
- T** Elevate the JM tube on a structural base if necessary for the outlet to be raised.
- U** Route condensate discharge line from to appropriate drain location.

Installation *(continued)*

Piping options

Overflow by-pass piping (JM-6 or JM-10 ONLY — do not apply to other models)

See Figure 4 and Figure 5 for installation with a y-fitting for an overflow by-pass line.

Locate the overflow discharge so flow can be easily seen. **Instruct the owner to notify the service technician immediately if flow through the overflow line is frequent or steady.**

Make sure the installation complies with all local code requirements.

Piping for multiple boilers/furnaces

Follow the guidelines on page 2 for combined piping with multiple boilers or furnaces.

As stated on page 2, do not connect a flue pipe condensate line to the same neutralizer as used for a boiler/furnace unless the boiler/furnace is individually vented, the vent will not allow rain water to enter the flue pipe, and no other appliance is connected to the same neutralizer tube.

WARNING

OUTDOOR INSTALLATIONS — provide and install electric heat tape on the condensate drain lines and around the JM tube to prevent possibility of neutralizer tube damage or line blockage due to freezing. Failure to comply with the following guidelines could result in severe personal injury, death or substantial property damage.

Figure 4 Y-fitting by-pass with floor-mounted boiler (see legend at left) — JM-6 or JM-10 ONLY

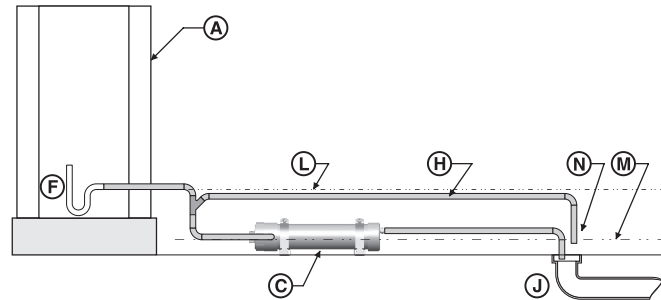
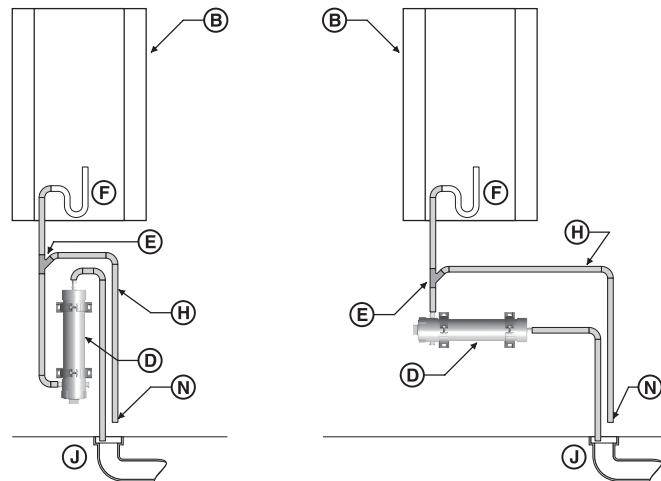

Figure 5 Y-fitting by-pass with wall-mounted boiler (see legend at left) — JM-6 or JM-10 ONLY



Legend for Figure 4 and Figure 5

- | | |
|--|--|
| A Condensing boiler or furnace, floor-mounted type | F Appliance condensate trap/condensate drain connection |
| B Condensing boiler or furnace, wall-mount type | H Overflow drain line (terminate so flow from line is easily seen) |
| C JM neutralizing tube floor-mounted (or multiple tubes piped in parallel) | J Floor drain, sump or condensate pump reservoir |
| D JM neutralizing tube wall-mounted (or multiple tubes piped in parallel) | L Bottom of appliance condensate drain connection — all condensate piping and components must be below this level |
| E Y-fitting, 3/4" PVC minimum — locate a minimum of 2 inches above the neutralizer tube and so the overflow line is below the bottom of appliances condensate drain connection (item L) | M Bottom of JM neutralizer tube outlet connection |
| | N Terminate the overflow line above the drain location so any flow from the line is easily visible |

Maintenance

Inspect frequently

Instruct the building owner to frequently inspect the JM tube and all condensate connections. The owner must notify a qualified technician if any problems are noticed.

Recharge as required

See instructions on page 2 for recharging or replacing the neutralizer tubes.

Replacement parts

Contact JJM Boiler Works, Inc., your local wholesaler or manufacturer's representative for replacement parts.