

NOTES:

1. FIT / FORM / FUNCTION SHALL FOLLOW PS-E.008.

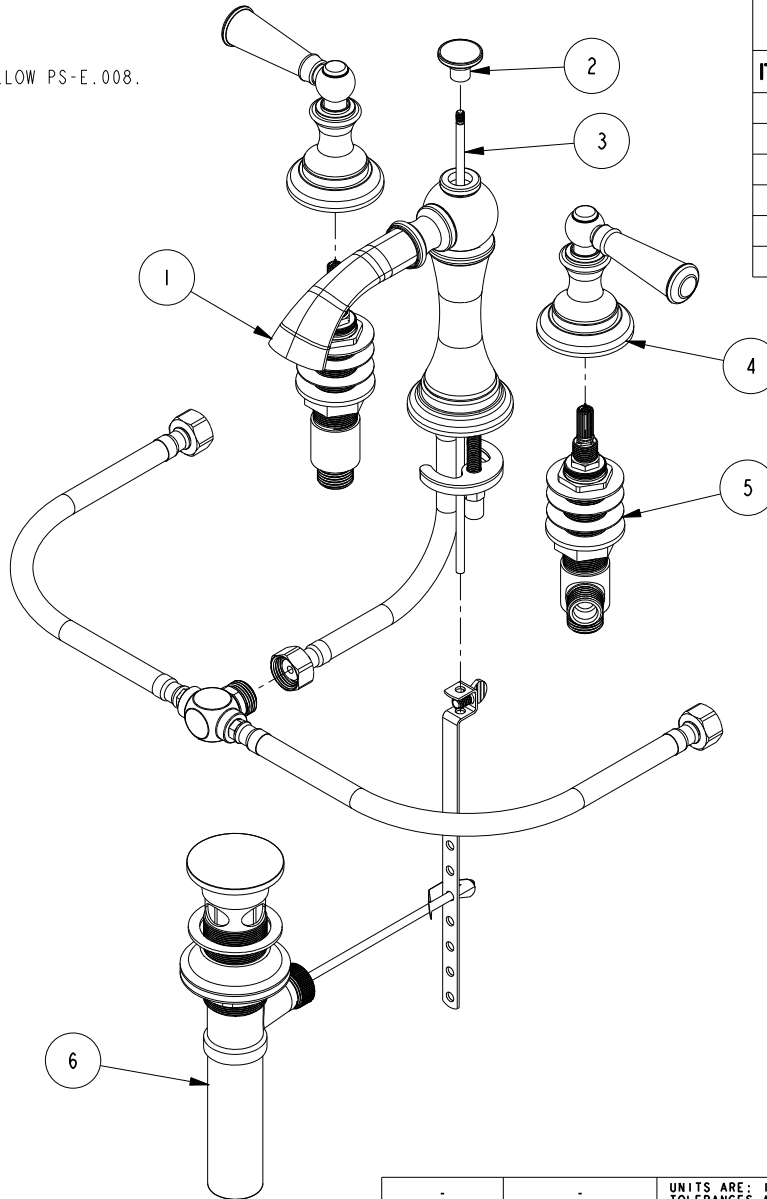

**BILL OF MATERIAL (CURRENT LEVEL)**

ITEM	PT/ASSY	DESCRIPTION	TYPE	QTY.
1	2-769	SPOUT ASSEMBLY, WIDE SPREAD	ASSEMBLY	1
2	11583	POP-UP KNOB	PART	1
3	10288	3/16" POP UP ROD	PART	1
4	3-379	LEVER HANDLE ASSEMBLY	ASSEMBLY	2
5	1-525_2400	W/S VALVE ASM	ASSEMBLY	1
6	325	POP UP ASSEMBLY	ASSEMBLY	1

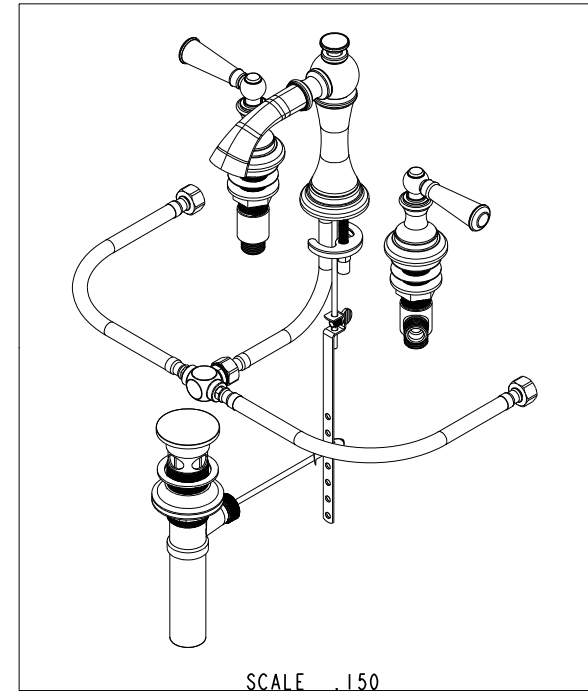

SCALE .150

-	D	EN-3764	12/07/18	J.M.
-	C	EN-2120	04/05/12	-
-	B	EN-1844	09/01/11	-
-	A	EN-1616	09/13/10	-
-	-	EN-1266	05/05/10	-
ZONE	REV	DESCRIPTION	DATE	APPROVED

COPYRIGHT 2005 BRASSTECH, INC. THESE DRAWINGS AND THE DESIGNS DEPICTED HEREIN ARE THE PROPRIETARY PROPERTY OF BRASSTECH. ANY USE OR REPRODUCTION IS SUBJECT TO THE EXPRESS APPROVAL OF BRASSTECH. UNAUTHORIZED USE IS STRICTLY PROHIBITED. ALL RIGHTS RESERVED.

TESTING	-	-	-
ASSEMBLY	-	-	-
PLATING	-	-	-
POLISHING	-	NEXT ASSY	USED ON
MACHINING	-	APPLICATION	
TOOLING	FIXTURE #	REMOVE ALL BURRS AND SHARP EDGES	

UNITS ARE: INCHES [MM]	
TOLERANCES ARE:	
FRACTIONS DECIMALS	ANGLES
±1/16"	±1°
.X ±.1 [2,5]	
.XX ±.06 [1,5]	
(X.XXX) DENOTES CRITICAL DIMS. ALL THREADS ARE CRITICAL	
DRAWN	ANDY NGUYEN 04/05/12
CHECKED	- 05/05/10
APPROVED	- 05/05/10

<b>BRASSTECH</b>		2001 CARNEGIE AVE. SANTA ANA, CA 92705 (949) 417-5207	
INCORPORATED			
W/S LAVATORY FAUCET			
DWG NO.	2450	REV	D
SCALE	.230	REF.	-
SHEET	1	OF	2

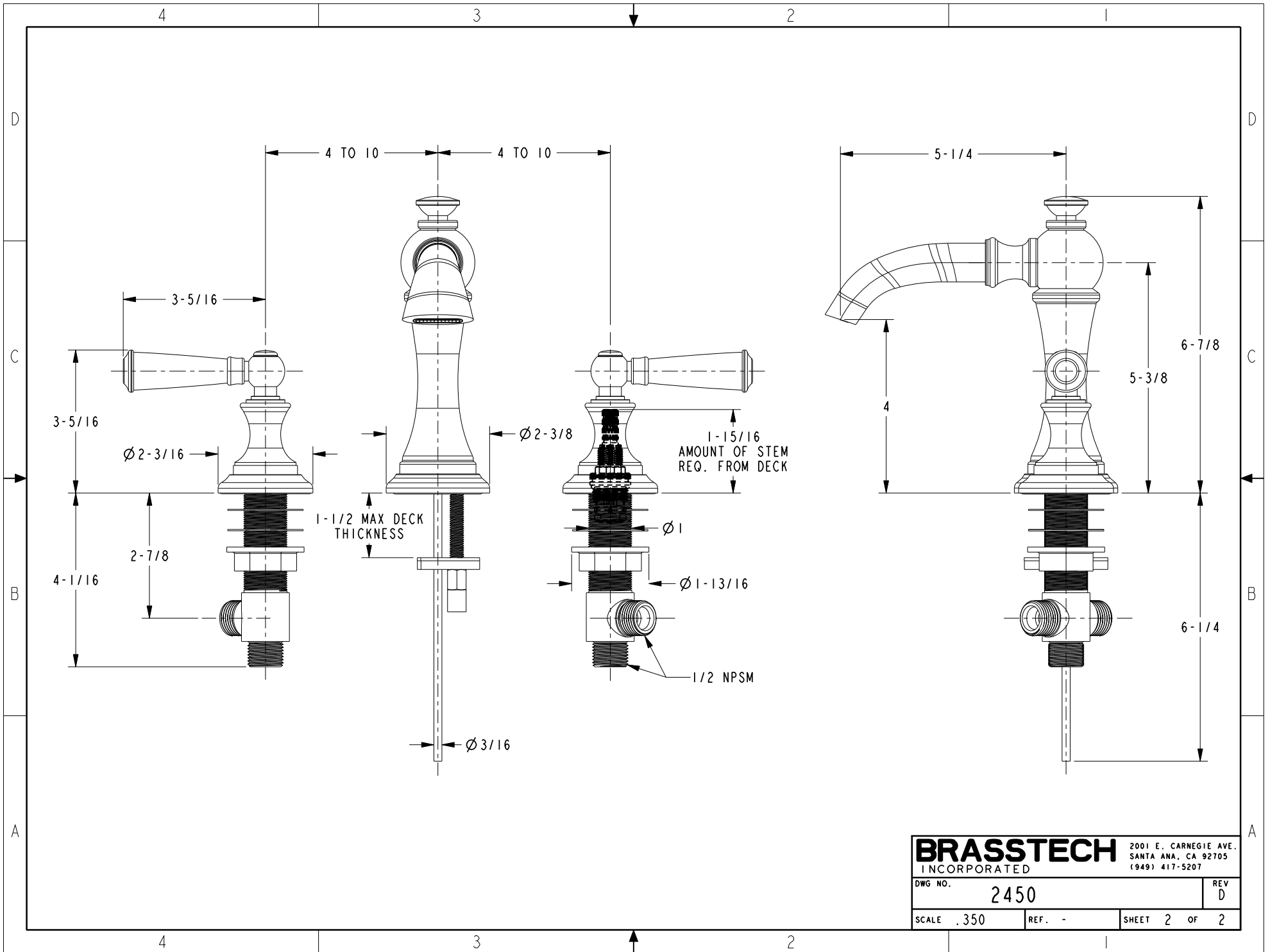

<b>BRASSTECH</b>		2001 E. CARNEGIE AVE.	
INCORPORATED		SANTA ANA, CA 92705	
		(949) 417-5207	
DWG NO.	2450	REV	D
SCALE	.350	REF.	-
		SHEET	2 OF 2