

Specifications: Model 318(60) NPT Valve

Horizontal Flow

Flow Direction
Arrow

Visual
Status
Window

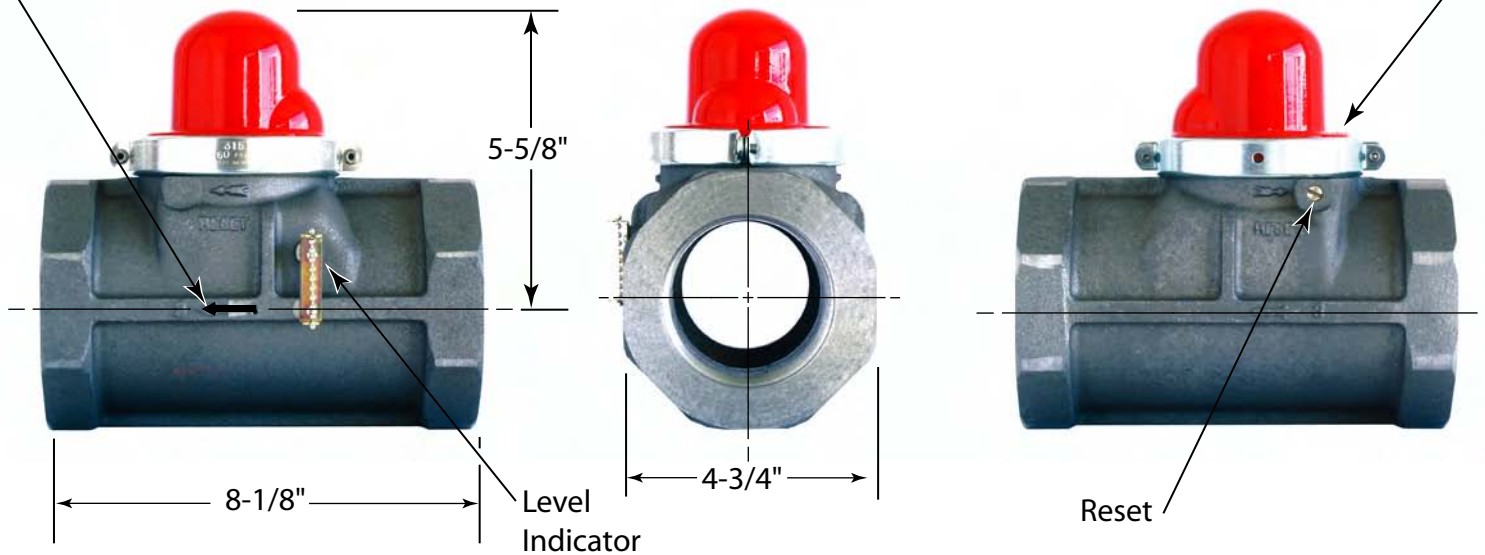

Valve Model#	CA-DSA No.	Length	Height	Octagon	Nominal Pipe Size	Threads Per Inch	APPLICATION	DATA
							Max. Pressure	Fuel
318	62-01	8-1/8"	5-5/8"	4-3/4"	2-1/2"	8	60 psi	Dry Fuel Gas

California Seismic Valves are UL listed in the USA. Certified by the California State Architect's Office, Approved by the City of Los Angeles, and are warranted free of manufacturer's defects for 30 years. All valves meet California Standards for Earthquake Actuated Automatic Gas Shut off Systems, Standard No. 12-23-1, ANSI Z21.70, 1981 and ASCE 25-97 Standards.

Pacific Seismic Products

233 East Avenue H-8 • Lancaster, CA 93535 • USA

Tel (661) 942-4499
 Fax (661) 942-0999
 TF (800) 4-GAS-OFF
www.4GasOff.net

