

# Installation Instructions / Warranty

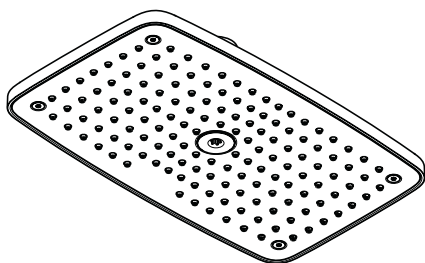

**Raindance E**  
27380xx1 / 27381xx1

**hansgrohe**

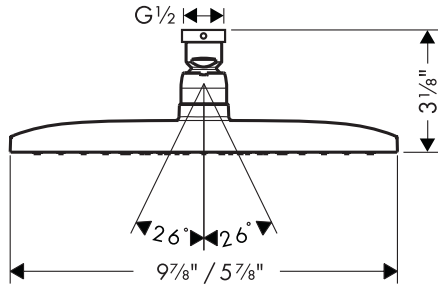

27380xx1

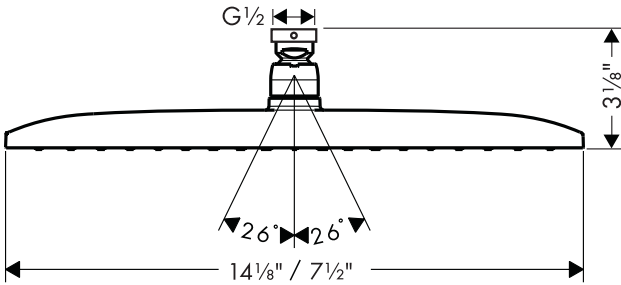

27381xx1

## Technical Information / Données techniques / Datos tecnicos

Recommended water pressure	Pression d'eau recommandée	Presión recomendada en servicio	15 - 75 psi
Max. water pressure	Pression d'eau maximum	Presión en servicio max.	145 psi
Recommended hot water temp.	Température recommandée d'eau chaude	Temperatura recomendada del agua caliente	120° - 140° F*
Max. hot water temp	Température maximum d'eau chaude	Temperatura del agua caliente max.	176° F*
Flow rate	Capacité nominale	Caudal máximo	2.5 gpm

\*Please know and follow all applicable local plumbing codes when setting the temperature on the water heater.

\* Vous devez connaître et respecter tous les codes de plomberie locaux applicables pour le réglage de la température du chauffe-eau.

\*Debe conocer y cumplir todos los códigos locales aplicables para ajustar la temperatura del calentador de agua.

## Installation Considerations

- For best results, Hansgrohe recommends that this unit be installed by a licensed, professional plumber.
- Please read over these instructions thoroughly before beginning installation. Make sure that you have all tools and supplies needed to complete the installation.
- To prevent scald injury, the maximum output temperature of the shower valve should be no higher than 120°F. In Massachusetts, the maximum output temperature of the shower valve can be no higher than 112°F.
- Keep this booklet and the receipt (or other proof of date and place of purchase) for this product in a safe place. The receipt is required should it be necessary to request warranty parts.

## À prendre en considération pour l'installation

- Pour de meilleurs résultats, Hansgrohe recommande que ce produit soit installé par un plombier professionnel licencié.
- Veuillez lire attentivement ces instructions avant de procéder à l'installation. Assurez-vous de disposer de tous les outils et du matériel nécessaires pour l'installation.
- Pour empêcher des blessures par ébullition, la température de sortie maximale du robinet de douche ne doit pas excéder 120°F. Au Massachusetts, la température de sortie maximale du robinet de douche ne doit pas excéder 112°F.
- Conservez ce livret et le reçu (ou une autre preuve sur laquelle figurent la date et l'endroit de l'achat) pour ce produit dans un endroit sûr. Le reçu est requis si vous commandez des pièces sous garantie.

## Consideraciones para la instalación

- Para obtener mejores resultados, la instalación debe estar a cargo de un plomero profesional matriculado.
- Antes de comenzar la instalación, lea estas instrucciones detenidamente. Asegúrese de tener las herramientas y los insumos necesarios para completar la instalación.
- Para evitar escaldaduras, la máxima temperatura de salida de la válvula de la ducha no debe exceder los 120°F. En Massachusetts, la máxima temperatura de salida de la válvula de la ducha no debe exceder los 112°F.
- Mantenga este folleto y el recibo (u otro comprobante del lugar y fecha de compra) de este producto en lugar seguro. El recibo se requiere en caso de ser necesario solicitar piezas bajo garantía.

## Installation

Install the showerhead on the arm.

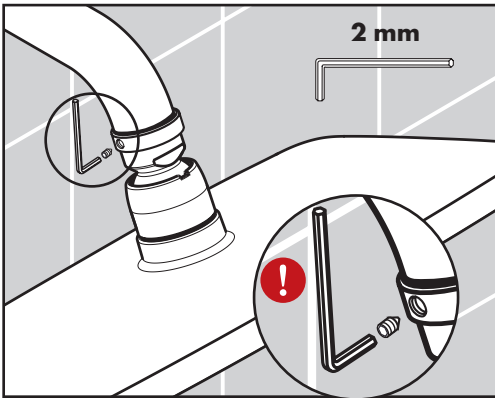
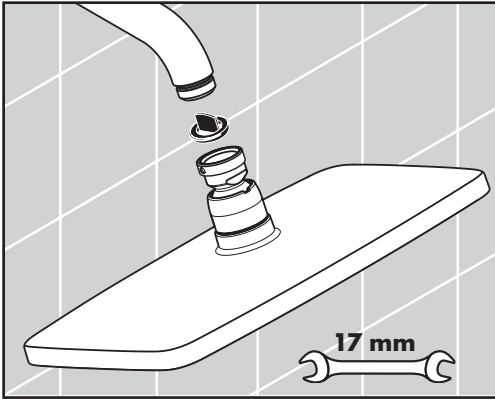

**Tighten the safety screw using a 2 mm Allen wrench.**

## Français

### Installation

Installez le pomme de douche sur le bras.

## Español

### Instalación

Instale la ducha cabezal.



**Serrez le vis à l'aide d'une clé hexagonale de 2 mm.**



**Instale el tornillo con una llave Allen de 2 mm.**

## English

### Cleaning

Clean scale deposits from the spray channels by rubbing across the channels using fingers or a sponge.

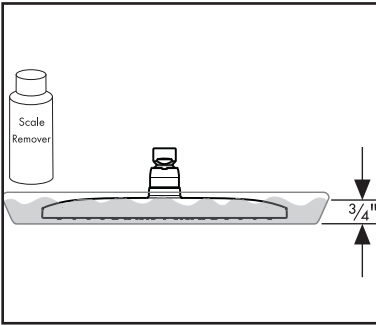
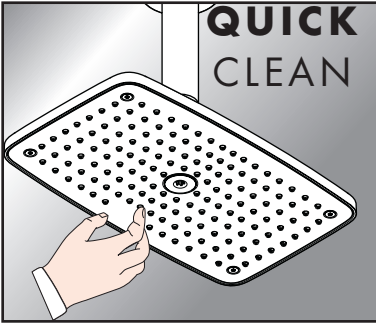

To remove scale buildup, soak the spray face in  $\frac{3}{4}$ " of scale remover, such as CLR or LimeAway.



**Always follow the instructions printed on the label of the scale remover.**

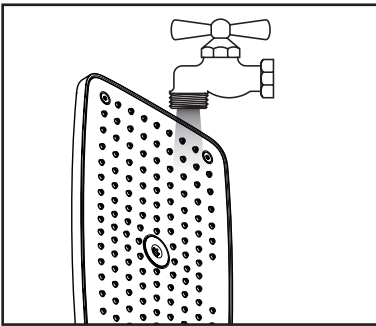

Rinse the showerhead with clear water.

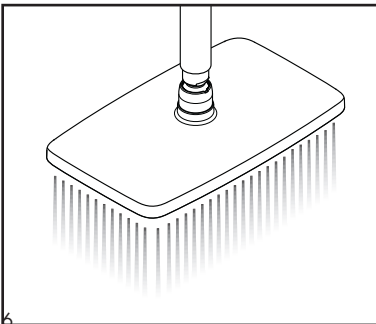

Install the showerhead.

Flush the showerhead for at least 1 minute.

### Nettoyage

Si les canaux de jet deviennent entartrés, frottez-les avec les doigts ou à l'aide d'une éponge pour en déloger les dépôts.

Si la face des jets s'entartré, faites-la tremper dans un détartrant commercial, tel que Lime-Away ou CLR.



**Suivez les instructions figurant sur l'étiquette du produit.**

Rincez la pomme de douche à l'eau claire.

Installez la pomme de douche et rincez au moins une minute.

### Limpiar

Elimine los depósitos calcificados de los canales de rociado frotándolos con los dedos o una esponja.

Elimine los depósitos calcificados de la superficie de rociado remojándola en un desincrustante comercial como Lime-Away o CLR.



**Siga las instrucciones de la etiqueta del producto.**

Enjuague la ducha con agua limpia.

Instale la ducha y lávela durante un minuto como mínimo.

## English

Soak the spray face in scale remover, such as CLR or Lime Away.



**Always follow the instructions printed on the label of the scale remover.**

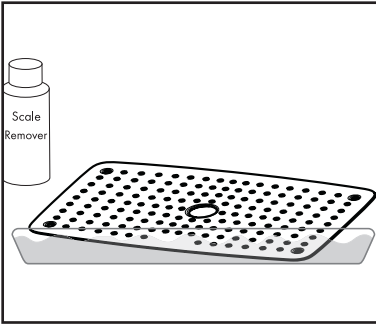

Rinse the spray face with clear water.

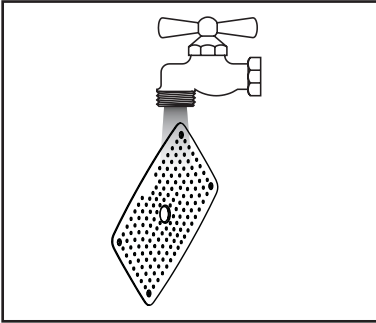

(1) Replace the spray face.

(2) Install the four screws. Tighten to 0.6 ft-lb using a 2.5 mm Allen wrench.

(3) Install the air jet. Tighten to 1.5 ft-lb using a 5 mm Allen wrench.

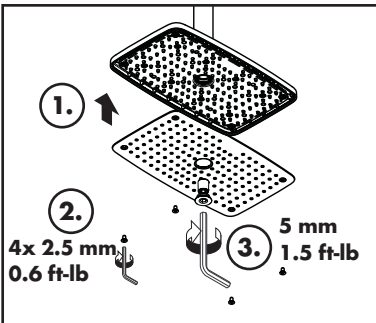



## Français

Trempez la face dans un détartrant commercial, tel que Lime-Away ou CLR.



**Suivez les instructions figurant sur l'étiquette du produit.**

Rincez la face à l'eau claire.

(1) Installez la face.

(2) Installez les quatre vis à l'aide d'un clé hexagonale de 2.5 mm.

(3) Installez l'injecteur d'air à l'aide d'un clé hexagonale de 5 mm.

## Español

Remojando la superficie de rociado en un desincrustante comercial como Lime-Away o CLR.



**Siga las instrucciones de la etiqueta del producto.**

Enjuague la superficie de rociado con agua limpia.

(1) Instale la superficie de rociado.

(2) Instale los cuatro tornillos con una llave Allen de 2.5 mm.

(3) Instale el inyector de aire con una llave Allen de 5 mm.

# Replacement Parts / Pièces détachées / Repuestos

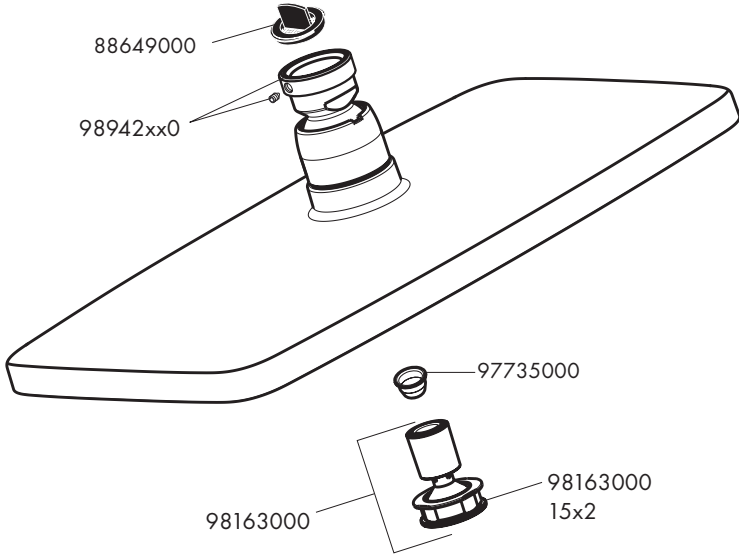

## Cleaning Recommendation for Hansgrohe Products

Modern bathroom faucets, kitchen faucets and shower products are made from different materials to comply with the needs of the market with regard to design and functionality. To avoid damage to the product, it is necessary to take proper care of it.

### For best results:

- Prevent the buildup of mineral scale and /or soap residue by cleaning your Hansgrohe product(s) when needed.
- Select a cleaning agent specifically intended for the type of product.
- **Do not** use these types of cleaners as they will cause damage to your Hansgrohe product:
  - ✘ Any cleaning agent containing hydrochloric acid, formic acid, lye, or acetic acid.
  - ✘ Abrasive cleaning powders, pads, or brushes.
  - ✘ Steam cleaners.
  - ✘ “No rinse” cleaning agents.
- **Always** follow the instructions provided by the manufacturer of the cleaning agent.
- **Do not** mix cleaning agents, unless directed by the manufacturer.
- **Do not** spray cleaners directly onto the product as drops could enter openings and gaps and cause damage. When using spray cleaners, spray the cleaner onto a soft cloth or sponge.
- **Always** rinse your Hansgrohe product thoroughly with clear water and polish dry with a soft cloth after cleaning.

### Important

- Residue from soaps and shampoos can cause damage. Rinse the product with clean water after each use.
- Residue from basin/tub/tile cleaner can cause damage to faucets and fittings. Immediately rinse any overspray from the Hansgrohe product.
- **Damage to the product caused by improper care or the use of improper cleaning agents is not covered by the warranty.**
- **If a component of the product is damaged, replace it, as there is risk of injury.**

## Conseil de nettoyage pour les produits Hansgrohe

De nos jours le sanitaire moderne, la robinetterie et les douchettes se composent de matériaux très différents pour satisfaire à la demande concernant le design et la fonctionnalité. Pour éviter les détériorations et les réclamations, aussi bien pour l'utilisation que pour le nettoyage prochain, certains critères seront à prendre en considération.

### **A prendre en considération lors de l'entretien de la robinetterie et de douchettes:**

- On doit seulement utiliser les produits de nettoyage qui sont formellement prévus pour ce domaine.
- Aucun contact avec l'application de nettoyeurs contenant de l'acide chlorhydrique, de l'acide formique ou de l'acide acétique qui peuvent causer de considérables détériorations.
- Les nettoyeurs à base d'acide phosphorique, aussi, ne sont pas à utiliser sans réserves.
- Le mélange de nettoyeurs en général n'est pas autorisé.
- L'utilisation de produits de nettoyage récurants et des ustensiles comme des frottoirs, des éponges à récurer et des torchons microfibrés est exclue.
- Les conseils d'entretien des producteurs de nettoyeurs sont à suivre obligatoirement.
- Le nettoyage est à faire correspondre avec le dosage, le temps d'action, spécifique à l'objet et à la nécessité.
- Le dépôt de calcaire est évité par un nettoyage régulier.
- Pour le nettoyage avec produit vaporisé liquide, en aucun cas sur la robinetterie, mais au contraire aspergé sur le chiffon (torchon, éponge) et effectuer comme cela le nettoyage, car les aérosols peuvent pénétrer dans les ouvertures et fentes de la robinetterie et peuvent provoquer des détériorations.
- Après le nettoyage rincez avec suffisamment d'eau claire pour éliminer les restes de produits attachés.
- L'utilisation d'appareil de nettoyage à vapeur n'est pas autorisée, car les températures importantes peuvent détériorer les produits.

### **Indications importantes**

- Les produits pour le corps comme les savons liquides, les shampooings ou les gels de douche peuvent causer des détériorations.
- Ici aussi on doit: Après l'utilisation rincer soigneusement les restes avec de l'eau.

### **Conseil de nettoyage**

- **Les détériorations imputables à un mauvais entretien ne peuvent être pris en considération par notre garantie.**
- Par l'action d'un nettoyeur sur les revêtements déjà endommagé il se produit une aggravation des dégâts.

## Recomendación de limpieza para los productos de Hansgrohe

Hoy en día, las griferías de baño y de cocina así como duchas modernas se componen de materiales muy distintos para satisfacer las exigencias del mercado respecto al diseño y la funcionalidad. Para evitar daños y reclamaciones hay que tener en cuenta ciertos aspectos tanto en el uso como en su limpieza.

### Para el cuidado de las griferías y las duchas en principio hay que seguir lo siguiente:

- Usar sólo detergentes previstos específicamente para este campo de aplicación.
- No aplicar detergentes que contengan ácido clorhídrico, fórmico o acético porque pueden causar daños importantes.
- Detergentes que contienen ácido fosfórico tampoco pueden ser aplicados ilimitadamente. Por regla general no se deben mezclar detergentes.
- Tampoco se deben utilizar utensilios abrasivos, como son polvos abrasivos, esponjas o paños de microfibra.
- Se tienen que seguir siempre las sugerencias de empleo de los fabricantes de los detergentes.
- La limpieza tiene que ser realizada según la dosificación y el tiempo de actuación, en función del objeto y ajustada a las necesidades específicas del mismo.
- Gracias a una limpieza periódica se pueden evitar los depósitos de cal.
- No conviene rociar el detergente en ningún caso sobre la grifería sino sobre los textiles y ejecutar la limpieza así, porque el líquido puede entrar en aperturas o hendiduras de la grifería y causar daños.
- Después de la limpieza hay que aclarar con suficiente agua para eliminar completamente el resto de detergente.
- La utilización de limpiadores a vapor no está permitida, las altas temperaturas pueden dañar los productos.

### Indicaciones importantes

- Los residuos de productos de aseo como jabón líquido, champús y gel de ducha pueden dañar también los materiales.
- Por lo que también se deberá prestar atención a lo siguiente: aclarar con abundante agua después del uso.
- Con materiales ya dañados la acción de detergentes incrementará el desgaste de estos.
- **Los componentes con superficies dañadas deberán cambiarse, en otro caso se corre el peligro de lesionarse.**
- Los daños que resulten de un uso inadecuado no están incluidos en nuestra garantía.

# Limited Consumer Warranty

This product has been manufactured and tested to the highest quality standards by Hansgrohe, Inc. ("Hansgrohe"). This warranty is limited to Hansgrohe products that are purchased by a consumer in the United States or Canada after March 1, 1996, and installed in either in the United States or in Canada.

## WHO IS COVERED BY THE WARRANTY

This warranty extends to the original purchaser only. This warranty is non-transferable.

## WHAT IS COVERED BY THE WARRANTY

The warranty covers only your Hansgrohe manufactured product. Hansgrohe warrants this product against defects in material or workmanship as follows:

Hansgrohe will replace at no charge for parts only or, at its option, replace any product or part of the product that proves defective because of improper workmanship and/or material, under normal installation, use, service and maintenance. If Hansgrohe is unable to provide a replacement and repair is not practical or cannot be made in timely fashion, Hansgrohe may elect to refund the purchase price in exchange for the return of the product.

## LENGTH OF WARRANTY

Replacement or repaired parts of products will be covered for the term of this warranty, as stated in the following two sentences. If you are a consumer who purchased the product for use primarily for personal, family or household purposes, this warranty extends for as long as you own the product and the home in which the product is originally installed. If you purchased the product for use primarily for any other purpose, including, without limitation, a commercial purpose, this warranty extends only (i) for 1 year, with respect to Hansgrohe & Commercial products, and (ii) for 5 years, with respect to Axor products.

## THIS WARRANTY DOES NOT COVER, AND HANSGROHE WILL NOT PAY FOR:

- A. Conditions, malfunctions or damage not resulting from defects in material or workmanship.
- B. Conditions, malfunctions or damage resulting from (1) normal wear and tear, improper installation, improper maintenance, misuse, abuse, negligence, accident or alteration; (2) the use of abrasive or caustic cleaning agents or "no-rinse" cleaning products, or the use of the product in any manner contrary to the product instructions; or (3) conditions in the home such as excessive water pressure or corrosion.
- C. Labor and other expenses for disconnection, deinstallation, or return of the product for warranty service (including but not limited to proper packaging and shipping costs), or for installation or reinstallation of the product.
- D. Accessories, connected materials and products, or related products not manufactured by Hansgrohe.
- E. Any Hansgrohe or Axor product sold for display purposes.
- F. Rubbed Bronze finish is subject to a 3-year limited warranty. Chrome and all PVD finishes are covered by the limited lifetime warranty.
- G. Hansgrohe Water Filtration System is subject to a 1-year limited warranty. Warranty does not include replacement filters.

## TO OBTAIN WARRANTY PARTS OR INFORMATION

Contact your Hansgrohe retailer, or contact Technical Service at:

Hansgrohe, Inc.  
1492 Bluegrass Lakes Parkway  
Alpharetta, GA 30004  
Toll-free 800-334-0455

In requesting warranty service, you will need to provide:

- 1. The sales receipt or other evidence of the date and place of purchase.
- 2. A description of the problem.
- 3. Delivery of the product or the defective part, postage prepaid and carefully packed and insured, to:

Hansgrohe, Inc.  
1492 Bluegrass Lakes Parkway  
Alpharetta, GA 30004  
Toll-free 800-334-0455

When warranty service is completed, any repaired or replacement product or part will be returned to you postage prepaid.

## **EXCLUSIONS AND LIMITATIONS**

**REPAIR OR REPLACEMENT (OR, IN LIMITED CIRCUMSTANCES, REFUND OF THE PURCHASE PRICE) AS PROVIDED UNDER THIS WARRANTY IS THE EXCLUSIVE REMEDY OF THE PURCHASER. HANSGROHE NEITHER ASSUMES NOR AUTHORIZES ANY PERSON TO CREATE FOR IT ANY OTHER OBLIGATION OR LIABILITY IN CONNECTION WITH THIS PRODUCT. HANSGROHE SHALL NOT BE LIABLE TO PURCHASER OR ANY OTHER PERSON FOR ANY INCIDENTAL, SPECIAL OR CONSEQUENTIAL DAMAGES, ARISING OUT OF BREACH OF THIS WARRANTY OR ANY IMPLIED WARRANTY (INCLUDING BUT NOT LIMITED TO ANY IMPLIED WARRANTY OF MERCHANTABILITY).**

Some States do not allow the exclusion or limitation of incidental or consequential damages, so the above limitation or exclusion may not apply to you. This warranty gives you specific legal rights, and you may also have other rights that vary from state to state.

**TO THE EXTENT PERMITTED BY LAW, ANY IMPLIED WARRANTIES OF MERCHANTABILITY AND FITNESS FOR A PARTICULAR PURPOSE, ARE LIMITED TO THE DURATION OF THE EXPRESS WARRANTY.**

Some states do not allow limitations on how long an implied warranty may last, so the above limitations may not apply to you. You may be required by law to give us a reasonable opportunity to correct or cure any failure to comply before you can bring any action in court against us under the Magnuson-Moss Warranty Act.

## **PRODUCT INSTRUCTIONS AND QUESTIONS**

Upon purchase or prior to installation, please carefully inspect your Hansgrohe product for any damage or visible defect. Prior to installing, always carefully study the enclosed instructions on the proper installation and the care and maintenance of this product. If you have questions at any time about the use, installation or performance of your Hansgrohe product, or this warranty, please write us or call us toll-free at 800-334-0455.

**hansgrohe**

Hansgrohe, Inc. • 1490 Bluegrass Lakes Parkway • Alpharetta, GA 30004  
Tel. 770-360-9880 • Fax 770-360-9887

**[www.hansgrohe-usa.com](http://www.hansgrohe-usa.com)**