

DH071/DR071

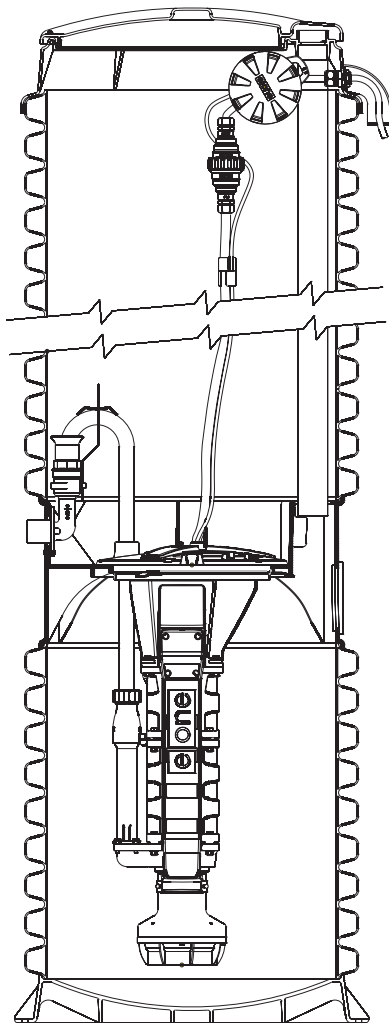

General Features

The model DH071 or DR071 grinder pump station is a complete unit that includes: the grinder pump, check valve, HDPE (high density polyethylene) tank, controls, and alarm panel. A single DH071 or DR071 is a popular choice for one, average single-family home and can also be used for up to two average single-family homes where codes allow and with consent of the factory.

- Rated for flows of 700 gpd (2650 lpd)
- 70 gallons (265 liters) of capacity
- Indoor or outdoor installation
- Standard outdoor heights range from 61 inches to 160 inches

The DH071 is the “hardwired,” or “wired,” model where a cable connects the motor controls to the level controls through watertight penetrations.

The DR071 is the “radio frequency identification” (RFID), or “wireless,” model that uses wireless technology to communicate between the level controls and the motor controls.

Operational Information

Motor

1 hp, 1,725 rpm, high torque, capacitor start, thermally protected, 120/240V, 60 Hz, 1 phase

Inlet Connections

4-inch inlet grommet standard for DWV pipe. Other inlet configurations available from the factory.

Discharge Connections

Pump discharge terminates in 1.25-inch NPT female thread. Can easily be adapted to 1.25-inch PVC pipe or any other material required by local codes.

Discharge

15 gpm at 0 psig (0.95 lps at 0 m)
11 gpm at 40 psig (0.69 lps at 28 m)
7.8 gpm at 80 psig (0.49 lps at 56 m)

Accessories

E/One requires that the Uni-Lateral, E/One’s own stainless steel check valve, be installed between the grinder pump station and the street main for added protection against backflow.

Alarm panels are available with a variety of options, from basic monitoring to advanced notice of service requirements.

The Remote Sentry is ideal for installations where the alarm panel may be hidden from view.

Patent Numbers: 5,752,315
5,562,254 5,439,180

NA0050P01 Rev C

OPTIONS : **DH071-74**
 DR071-74

(HARD WIRED
LEVEL CONTROLS)

(WIRELESS
LEVEL CONTROLS)

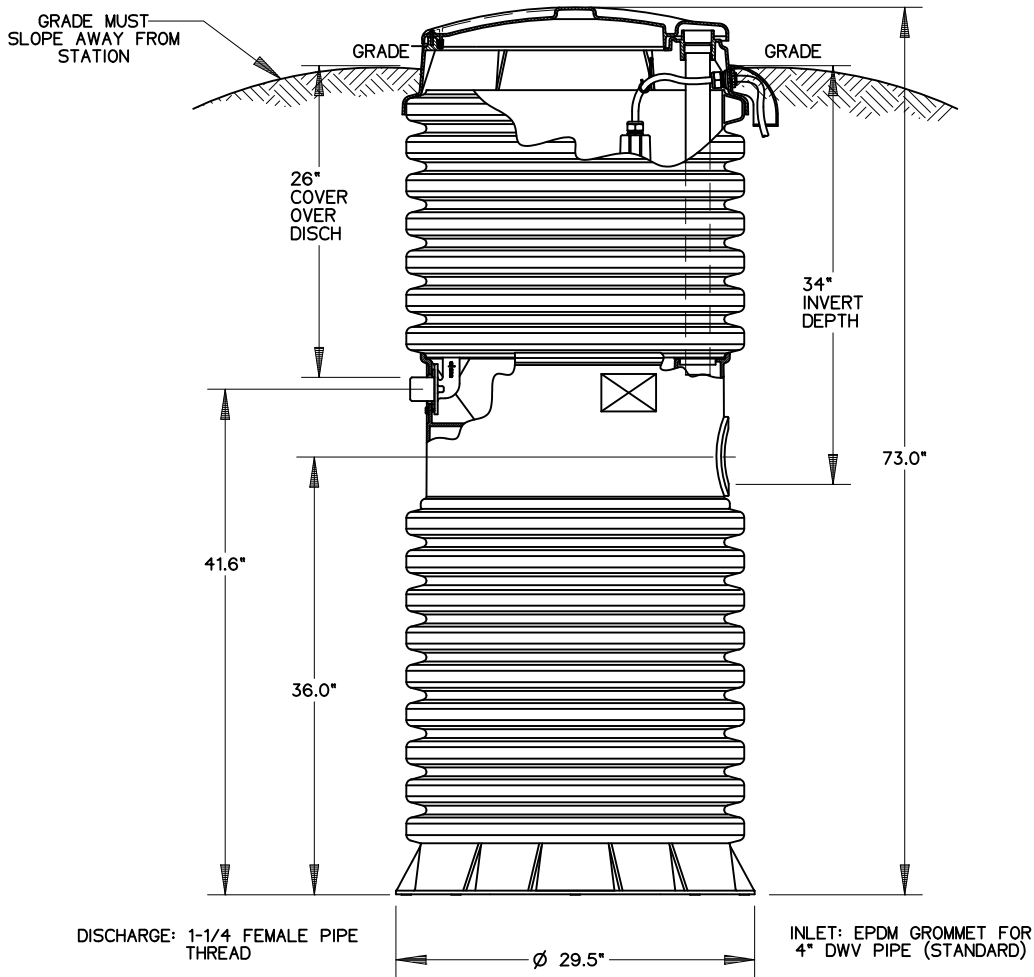

CONCRETE BALLAST MAY BE REQUIRED
SEE INSTALLATION INSTRUCTIONS
FOR DETAILS

NOTE: DIMENSIONS ARE FOR REF ONLY

AD	CAH	07/12/07	C	1/16
DR BY	CHK'D	DATE	ISSUE	SCALE



MODEL DH071-74 / DR071-74

NA0050P05