

BIG BUBBLE DUCT INSULATION R-8.0

MANUFACTURER'S SUGGESTED INSTALLATION INSTRUCTIONS

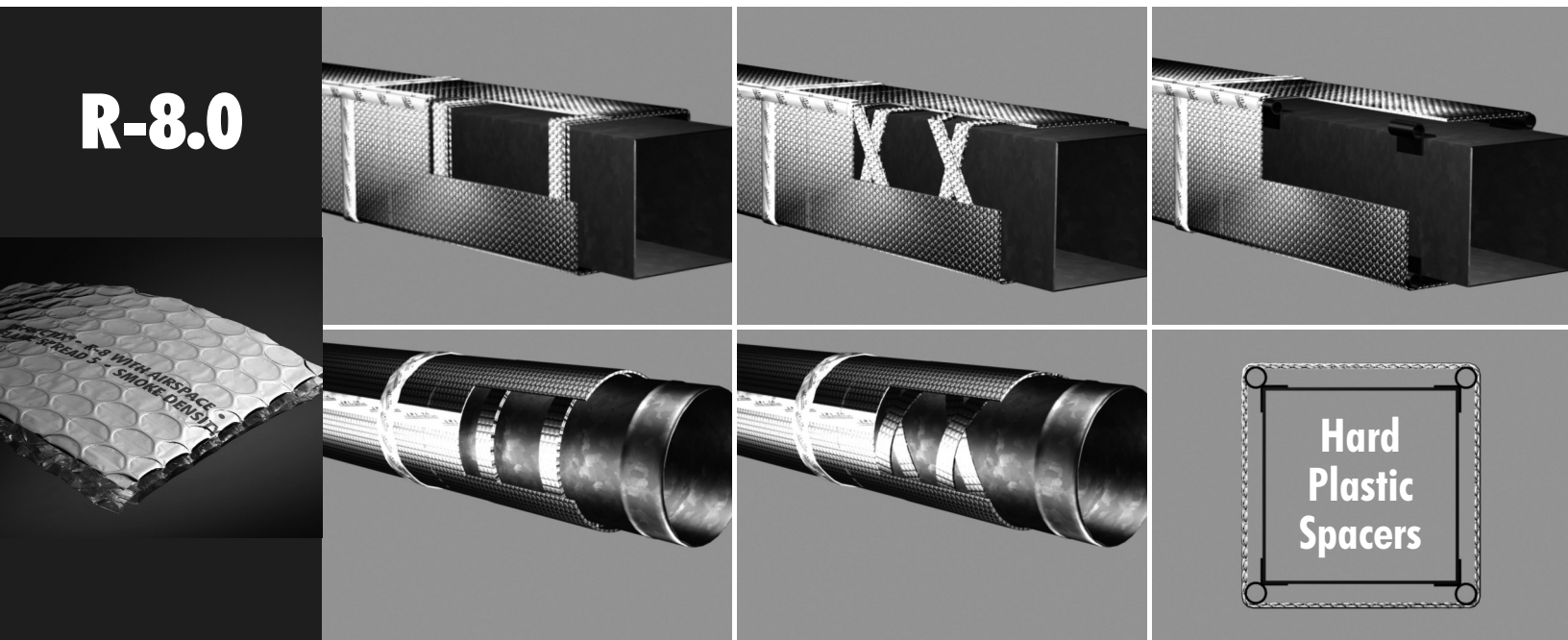

THERE ARE 3 OPTIONS - METHODS 1 & 2 ARE APPLICABLE TO EITHER ROUND OR RECTANGULAR DUCTS:

Note: Installation instructions/illustrated drawings are recommendations only, proper local construction methods are the responsibility of the installer.

1. SPACER PERPENDICULAR TO DUCT DIRECTION METHOD

SPACER: HVSPW02025 - REFLECTIX® SPIRAL PIPE WRAP 2" x 25'

- Refer to the (2) left hand diagrams above. Make sure all sheet metal joints, seams and penetrations are sealed.
- Double wrap and secure spacer material to the duct at 24" to 36" intervals. Use a UL 181 approved tape to fasten the spacer in place.
- Verify the circumference of the duct at the mid-point of a spacer strip. Cut the Reflectix® product to this length plus 1".
- Wrap the product around the duct and securely tape the linear and circumference seams (overlapping 1" - 2") with a UL 181 approved tape (goal is an air-tight, snug seam seal). Do not leave any exposed duct or space where air can enter between the duct and the Reflectix®.

2. SPACER WRAPPED IN CANDY CANE FASHION METHOD

SPACER: HVSPW02025 - REFLECTIX® SPIRAL PIPE WRAP 2" x 25'

- Refer to the middle two diagrams above. Make sure all sheet metal joints, seams and penetrations are sealed.
- Double wrap and secure spacer material to the duct in a candy cane fashion. First, proceed down the duct in one direction then reverse direction and crisscross (overlap) the spacer in the other direction. Use a UL 181 approved tape to fasten the spacer in place.
- Verify the circumference of the duct with the spacer strips in place. Cut the Reflectix® product to this length plus 1".
- Wrap the product around the duct and securely tape the linear and circumference seams (overlapping 1" - 2") with a UL 181 approved tape (goal is an air-tight, snug seam seal). Do not leave any exposed duct or space where air can enter between the duct and the Reflectix®.

3. HV SPACERS AFFIXED TO CORNERS METHOD (RECTANGULAR DUCTS ONLY)

SPACER: HVSPACER - REFLECTIX® HARD PLASTIC CORNER SPACER

- Refer to the (2) right hand diagrams above. Make sure all sheet metal joints, seams and penetrations are sealed.
- Make sure the duct is free from dust and dirt by wiping it down with a shop rag.
- Install the HV Spacers to all 4 corners of the duct. Place the spacers every 36" apart. Verify the circumference of the duct over the top of the spacers.
- Cut the Reflectix® product to this length plus 1". Wrap the Reflectix® over the spacers.
- Fasten the Reflectix® by either taping the seam with a UL 181 approved tape, or plier stapling the two edges together (goal is an air-tight, snug seam seal).
- If the duct is supported with saddle clamps, make sure to install a spacer on the two bottom edges of the duct directly between the clamp and the duct. If the clamps are installed around the duct (such as plumbers tape), make sure that the seam is taped to prevent air movement.

PLEASE NOTE REGARDING HANGERS:

Strap Hanger: Wrap Reflectix® with the seam at the hanger. Tape seam tightly around hanger.

Saddle Hanger: Make sure that there is a spacer below the hanger between the insulation and the duct to prevent the insulation from touching the duct.

BIG BUBBLE DUCT INSULATION R-6.6

MANUFACTURER'S SUGGESTED INSTALLATION INSTRUCTIONS

R-6.6

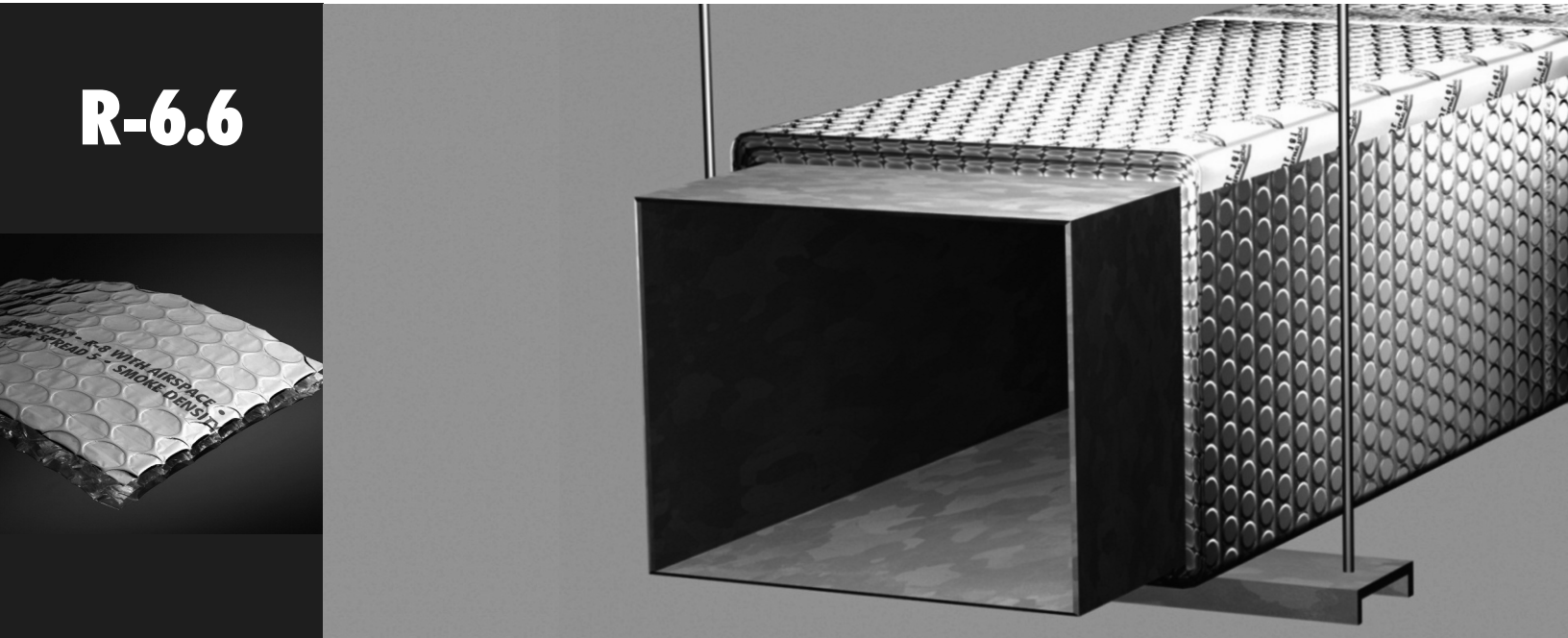

Note: Installation instructions and illustrated drawings are recommendations only, while proper local construction methods are the responsibility of the installer.

ROUND OR RECTANGULAR DUCTS

- Make sure all metal joints, seams and penetrations are sealed.
- Verify circumference of the duct.
- Rectangular Duct: Cut the Reflectix® product to this length plus the width of the top panel of the duct.
- Round Duct: Cut the Reflectix® product to this length plus an additional 25% in length.
- Wrap the product around the duct and overlap the top panel (rectangular) or upper 25% (round) of the duct.
- Securely tape the linear and circumference seams with a UL 181 approved tape (goal is an air-tight, snug seam seal). Do not leave any exposed duct or space where air can enter between the duct and the Reflectix®.

PLEASE NOTE REGARDING HANGERS:

Strap Hanger: Wrap Reflectix® with the seam at the hanger. Tape seam tightly around hanger.

Reflectix, Inc. #1 School St. (PO Box 108) Markleville, IN 46056 • (800) 879-3645 • Fax: (765) 533-2327 • www.reflectixinc.com