

PRODUCT SPECIFICATION DRAWING
HOLDRITE® #117-3L through -8L Series No-Hub Fitting Restraints

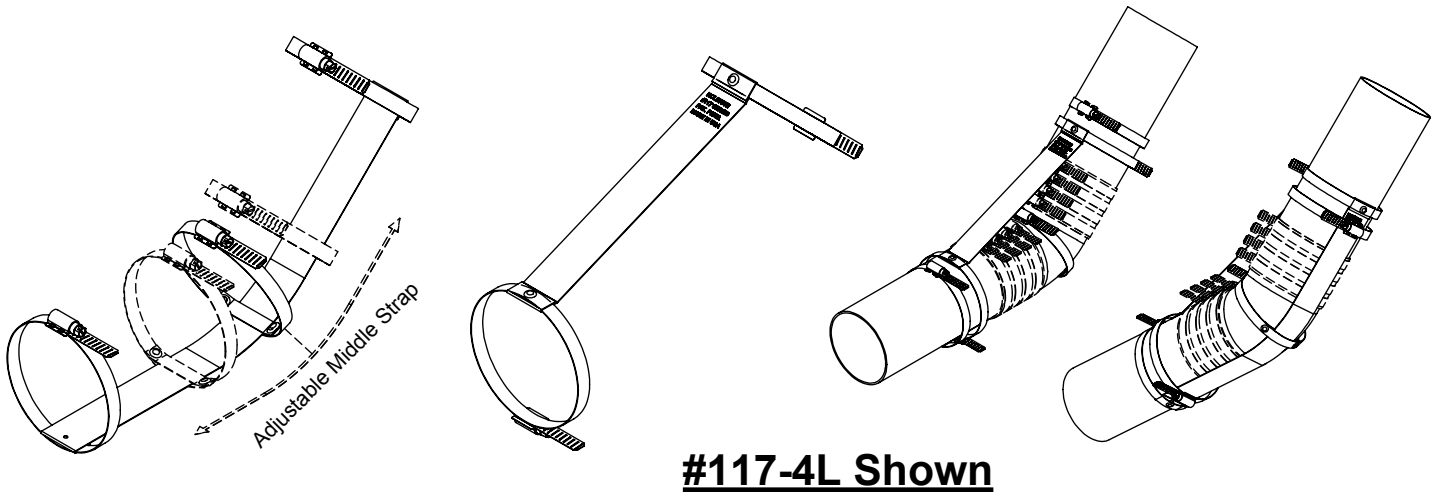

THE HOLDRITE® #117-L Series No-Hub Fitting Restraints are designed to reinforce no-hub cast iron installations at 22-1/2°, 45° & 60° changes of direction in accordance with the installation instructions of U.S. cast iron soil pipe manufacturers, CISPI Designation 310-11 and the 2006 CISPI Installation Handbook. The #117-3L (2" & 3" size), #117-4L (4" size), #117-5L (5" size), #117-6L (6" size) and #117-8L (8" size) retain the 1/16 bend (22-1/2°), 1/8 bend (45°) or 1/6 bend (60°) elbow onto the adjoining piping. All stainless steel bands must be tightened to 60 in/lbs minimum. When installed correctly, these restraint brackets achieve a safe thrust pressure rating equal to 50' head of water pressure.

NOTE:

While these restraint kits aid in compliance with the 2006 CISPI Handbook, they are not intended to suggest that no-hub pipe and fittings should be subjected to pressures in excess of the pipe manufacturers' recommendations.

NOTE: The diagonal strap can be routed under the center stainless steel band.

Product Information:

- Material:
 Strap: 24GA, CRS, galvanized
 Bands: Stainless steel body, band & screw
- Torque: 60 in/lbs. minimum on band
- Patent pending
- Thrust force restraint test data available upon request
- Refer to installation instructions at www.holdrite.com

THIS INFORMATION IS PROPRIETARY TO HOLDRITE AND IS SUBJECT TO CHANGE WITHOUT NOTICE. IT MAY NOT BE REPRODUCED IN PART OR WHOLE WITHOUT WRITTEN AUTHORIZATION.



CONVERTING MAKESHIFT METHODS INTO ENGINEERED SOLUTIONS™

800-321-0316 OR 760-744-6944 / FAX: 760-744-0507 / WWW.HOLDRITE.COM
 spec_117-4L_-5L_-6L_-8L_RevD

Product Submittal	
Job Name:	
Date:	
Part Number:	Qty:
Architect / Owner:	
Contractor:	
Notes:	