



The **ICM492** constantly monitors line voltage and protects single-phase equipment against low and high voltage conditions, and rapid short cycling due to voltage fault or power interruption. Its easy-view, backlit digital display makes it user friendly to read and monitor voltage conditions, and adjust parameters to meet specific needs.



Features

- **Protects Against Over and Under Voltage, and Rapid Short Cycling caused by Transient Faults and Power Interruptions**
- **Easy-view, Backlit Digital Display**
- **RMS Voltage Monitoring**
- **Adjustable Voltage Set Point**
- **Adjustable Over Voltage Setting**
- **Adjustable Under Voltage Setting**
- **Adjustable Anti-Short Cycle Time Delay**
- **Adjustable Response Time**
- **Control Mode**
- **5-Fault Memory**
- **Universal Line voltage Input**
- **Heavy Duty SPDT Relay Output**
- **Universal Control Voltage Input (for integrating a thermostat)**

Mode of Operation

The **ICM492** continuously monitors incoming line voltage for faults and displays RMS voltage on the digital display. When line voltage is appropriate, the **ICM492** will close COM and N.O. relay contacts. When incoming line voltage is outside of the user selected parameters, the **ICM492** will close COM and N.C. relay contacts and indicate a fault condition by flashing FAULT on display. The SELECT menu has the following user adjustable settings: voltage setpoint, time delay, over voltage, under voltage, control mode, and response time. Time delay prevents system short cycling caused by transient faults and rapid power interruptions. The response time on the fault condition can be adjusted to help reduce nuisance trips from transient faults. When Control Mode setting is selected ON, the **ICM492** will close COM and N.O. relay contacts only when control voltage is present at Control Voltage terminals. The relay contacts can be used to direct drive the load as long as current rating is not exceeded.

Specifications

User Adjustable Settings:

- **Voltage set point:** 95-280V
- **Anti-short cycle time delay:** 0-720 seconds
- **Over voltage setting:** 5-25%
- **Under voltage setting:** 5-25%
- **Control mode:** On and Off
- **Response time:** 0.1 to 10 seconds

Inputs:

- **Line Voltage:** 80 to 300 VAC
- **Frequency:** 50/60 Hz
- **Accuracy:** ±2%
- **Low Power Consumption:** max 50 mA @ 120V, max 100 mA @ 240V
- **Control Voltage:** 24 to 240 VAC

Output:

- **Type:** dry relay contacts
- **Form:** SPDT
- **Relay Contact Ratings:**
 - **N.C. Contacts:** 10A resistive @ 277 VAC
 - **N.O. Contacts:** 10A resistive @ 277 VAC
- **Connection Terminals:** 0.25" male fast-on

Mechanical:

- **Case Dimensions:** 3"L x 3.2"W x 1.35"H
- **Unit Weight:** 0.36 lbs.

Environmental:

- **Operating temperature range:** -30°C to +70°C
- **Storage temperature range:** -40°C to +85°C
- **Max. Oper./Storage Relative Humidity:** 95% non-condensing

System Diagram

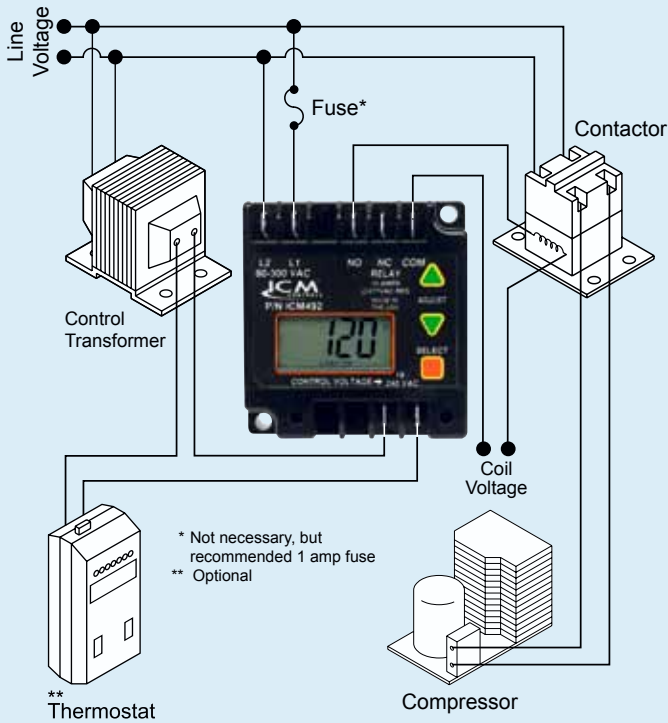

Wiring Diagram #1

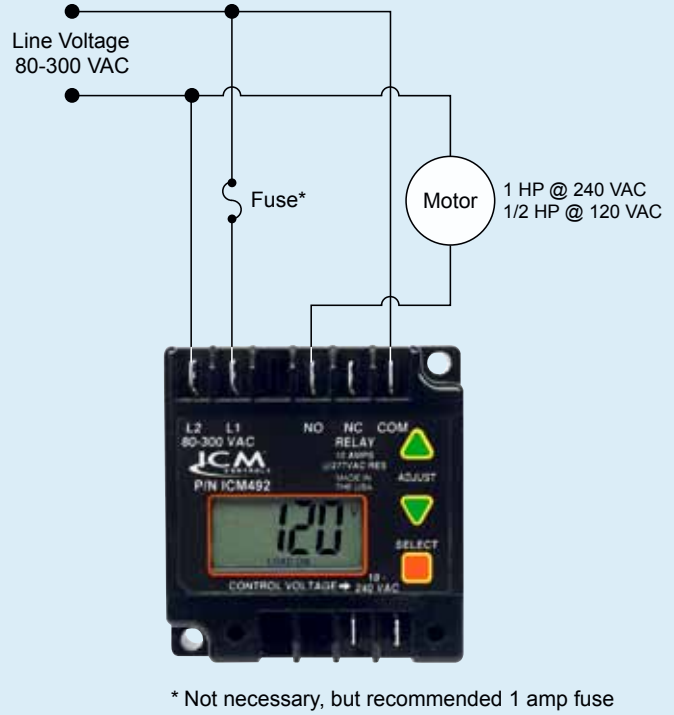

Wiring Diagram #2

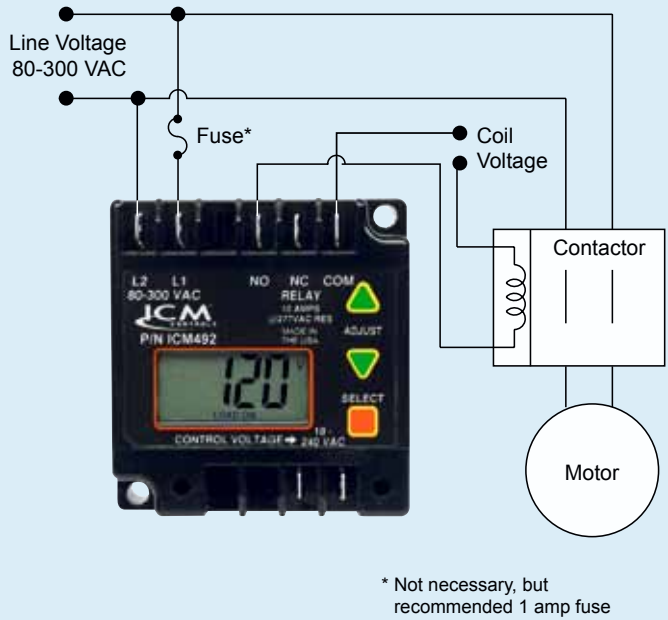

Wiring Diagram #3

