



INSTALLATION, OPERATION & MAINTENANCE INSTRUCTIONS

1455 Kleppe Lane ♦ Sparks, NV 89431-6467 ♦ (775) 359-4712 ♦ Fax (775) 359-7424
E-mail: haws@hawsco.com ♦ website: www.hawsco.com

No. 0002080229 (8)

Model TWBS.HF Tempered Water Blending System

NOTE TO INSTALLER: Please leave this information with the Maintenance Department.

LIMITED WARRANTY

HAWS® warrants that this specific product is guaranteed against defective material or poor workmanship for a period of **three years from date of shipment**. HAWS liability under this warranty shall be discharged by furnishing without charge F.O.B. HAWS Factory any goods, or part thereof, which shall appear to the Company upon inspection to be of defective material or not of first class workmanship, provided that claim is made in writing to Haws within a reasonable period after receipt of the product. Where claims for defects are made, the defective part or parts shall be delivered to the Company, prepaid, for inspection. HAWS will not be liable for the cost of repairs, alterations or replacements, or for any expense connected therewith made by the owner or his agents, except upon written authority from HAWS, Sparks, Nevada. HAWS will not be liable for any damages caused by defective materials or poor workmanship, except for replacements, as provided above. Buyer agrees that Haws has made no other warranties either expressed or implied in addition to those above stated, except that of title with respect to any of the products or equipment sold hereunder and that HAWS shall not be liable for general, special, or consequential damages claimed to arise under the contract of sale.

The thermostatic mixing valve manufactured by HAWS is warranted to function if installation and maintenance instructions provided are adhered to. The units also must be used for the purpose, which they were intended. This product is intended to supplement first-aid treatment. Due to widely varying conditions HAWS cannot guarantee that the use of this emergency equipment will prevent serious injury or the aggravation of existing or prior injuries.

NO OTHER WARRANTIES EXPRESSED OR IMPLIED ARE AUTHORIZED, PROVIDED OR GIVEN BY HAWS.

SHOULD YOU EXPERIENCE DIFFICULTY WITH THE INSTALLATION OF THIS MODEL, OR REQUIRE REPLACEMENT PARTS, PLEASE CALL:

TECHNICAL SUPPORT: 1-800-766-5612

FOR CUSTOMER SERVICE: 1-888-640-4297

INSTALLATION, OPERATION & MAINTENANCE INSTRUCTIONS

Valve operating principle:

The Haws Corporation TWBS.HF Emergency Valve thermostatically mixes hot and cold water to provide a safe fluid supply for emergency showers and eyewash equipment. The TWBS.HF valve contains a secondary high temperature limit valve to provide additional protection to the user in the event of main tempering valve malfunction. Additionally, to ensure a fail-safe water supply for emergency shower and eyewash stations, a pressure sensing diverter valve is provided that sends a pressure signal to open the cold water by-pass valve in the event of hot water pressure loss, main valve thermostat malfunction, or clogged cold water check-stop.

Valve features:

- Paraffin filled thermostats with industry leading response time.
- Tempered water: Temperature is factory set to 85°F (29°C).
- Tempered water: High temperature limit is factory set to 85°F (29°C).
- The over temperature valve is calibrated to shut off the hot water inlet flow when the outlet temperature exceeds 95°F (35°C).
- Cold water by-pass valve opens if hot water fails.
- Actively suspends hot water flow when cold water supply is lost to protect against scalding.
- Cold water by-pass valve is closed during normal operation, regardless of flow rate.

Valve sizing:

The flow capacity table shown below contains discharge flow rates @ 85°F (29°C) outlet temperature with the valve tested under the conditions described by ASSE 1071.

Flow Capacity								
Model No.	Min flow	Pressure drop across valve						Cold water
		5 PSI	10 PSI	20 PSI	30 PSI	40 PSI	45 PSI	By-pass @ 30 PSI
TWBS.HF	1.0* GPM	32 GPM	45 GPM	64 GPM	78 GPM	90 GPM	95 GPM	79

* Denotes minimum flow rate without re-circulation.

Valve specifications:

- Maximum operating pressure: 125 PSI
- Minimum / Maximum hot water temperature: 120°F / 180°F (49°C - 82°C).
- Tempered water temperature adjustment range: 60°F – 85°F (15°C - 29°C)
- Compliance/Listings: ASSE 1071, NSF 61, NSF 372, California Lead Plumbing Law and applicable sections of CSA B125.3.

IMPORTANT

To ensure the proper operation of the TWBS.HF valve it is essential to:

- Properly size the valve for each application.
- Keep the outlet temperature set between 60°F and 85°F (15°C - 29°C).
- Haws recommends a weekly testing and recording of the outlet water temperature.

Failure to comply with installation and/or maintenance instructions could result in valve failure.

INSTALLATION, OPERATION & MAINTENANCE INSTRUCTIONS

Valve operation:

Hot and cold water flows into the valve through two ports, marked "C" for cold and "H" for hot. The inlet water passes through check valves and valve seats into a mixing chamber, where the main thermostat is located. The temperature setting is controlled via an adjusting screw which is located at the front of the valve. If the inlet temperature fluctuates or the pressure changes, the main thermostat moves an internal plunger which corrects outlet temperature back to the initial setting. In the event of cold water failure, the main thermostat completely closes the hot seat. Additionally, the cold water by-pass valve provides adequate cold water flow if the hot inlet fails. For additional safety, a second high temperature limit thermostat is located in the outlet stream. This thermostat shuts off at 95° F or higher temperatures, closing the hot inlet.

Valve installation instructions:

Installation and field adjustment of this device are the responsibility of the installer and shall be carried out in accordance with the following instructions:

1. This valve must be accessible for testing, adjustment and/or maintenance in its installed position.
2. Shutoff valves must be installed and closed for maintenance purposes, and provisions shall be made to prevent unauthorized shutoff.
3. Flush the hot and cold supply lines prior to installation.
4. Connect the hot and cold supplies to the marked inlets.
5. Connect the outlet to the tempered water supply line.
6. Pressurize the emergency tempering valve and check all connections for leaks.

Installation test procedure:

1. Confirm the discharge temperature at the eyewash station or drench shower. Reset the outlet temperature, if necessary, based on medical/safety authorities guidelines. (This establishes the pre-set level). Note: Turning the temperature adjusting screw counterclockwise will increase the temperature.
2. Close the hot water supply: The cold water by-pass must open and provide significant flow.
3. Open the hot water supply: The outlet temperature should return to the pre-set level.
4. Close the cold water supply (Do not use the check valve.): The flow rate must comply with the maximum cold shut off flow allowed by ASSE 1071 for this valve size.
5. Open the cold water supply: The outlet temperature should return to the pre-set level.
6. Close the cold water check valve: The cold water by-pass must open and provide sufficient flow.
7. Open the cold water check valve: The outlet temperature should return to the pre-set level.

Recommended valve testing procedure:

1. Open the eyewash and/or drench shower stations: Confirm and record the outlet temperature.
2. Close the hot water inlet: The cold water by-pass valve must open.
3. Open the hot water inlet: The outlet temperature should return to the pre-set level.
4. Close the cold water supply (Do not use the check valve.): The flow rate must comply with the maximum cold shut off flow allowed by ASSE 1071 for this valve size.
5. Open the cold water supply: The outlet temperature should return to the pre-set level.

INSTALLATION, OPERATION & MAINTENANCE INSTRUCTIONS

TROUBLESHOOTING PROCEDURE		
PROBLEM CONDITION	REPAIR CHECKLIST	
1. Cold flow only.	a.	Confirm the hot water inlet pressure; it must be within +/- 10% of the cold inlet pressure.
	b.	Confirm the hot water check-stop and/or upstream valve is fully open.
	c.	Confirm the hot inlet check-stop screen is free of debris. Clean if necessary.
2. Flow rate is too low.	a.	Confirm all upstream inlet valves are fully open.
	b.	Confirm the downstream valve is fully open.
	c.	Confirm the hot and cold inlet pressures; both supplies must be 30 PSI, minimum.
	d.	Confirm both the check-stops are free of debris. Clean if necessary.
3. No flow.	a.	Confirm all upstream inlet valves are fully open.
	b.	Confirm the downstream valve is fully open.
	c.	Confirm the hot and cold inlet pressures; both supplies must be 30 PSI, minimum.
	d.	Confirm both the check-stops are free of debris. Clean if necessary.
4. Significantly lower outlet temperature.	a.	Confirm the hot water inlet pressure; it must be within +/- 10% of the cold inlet pressure.
	b.	Confirm the cold water bypass valve is free of debris. Clean if necessary.

INSTALLATION, OPERATION & MAINTENANCE INSTRUCTIONS

WEEKLY TEST RESULTS (ONE YEAR)*							
WEEK NO. (1 THRU 26)	OUTLET TEMP (° F)	COLD BY-PASS OPEN? (Y/N)	COLD WATER FAILURE? (PASS/FAIL)	WEEK NO. (27 THRU 52)	OUTLET TEMP (° F)	COLD BY-PASS OPEN? (Y/N)	COLD WATER FAILURE? (PASS/FAIL)
1				27			
2				28			
3				29			
4				30			
5				31			
6				32			
7				33			
8				34			
9				35			
10				36			
11				37			
12				38			
13				39			
14				40			
15				41			
16				42			
17				43			
18				44			
19				45			
20				46			
21				47			
22				48			
23				49			
24				50			
25				51			
26				52			

**Notice to testing personnel: This sheet should be used as a template for capturing the test results of this valve for one year. Please make a copy of this sheet for future testing prior to writing on this one.*

ITEM	DESCRIPTION	PART NO.
1	KIT, REPAIR, TWBS.HF, COMPLETE	VRKHF.A
2	KIT, REPAIR, TWBS.HF, MAIN MIXING CHAMBER	VRKHF.B
3	KIT, REPAIR, TWBS.HF, CHECK STOPS	VRKHF.C
4	KIT, REPAIR, TWBS.HF, HOT SHUT OFF VALVE	VRKHF.D
5	KIT, BASIC MAINT, TWBS.HF, T-STATS+O-RINGS	VRKHF.E
6	KIT, REPAIR, TWBS.HF COLD BYPASS VALVE	VRKHF.F

VALVE COVER AND COVER BOLTS SHOWN FOR REFERENCE ONLY

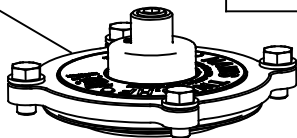

EACH KIT INCLUDES INSTALLATION INSTRUCTIONS

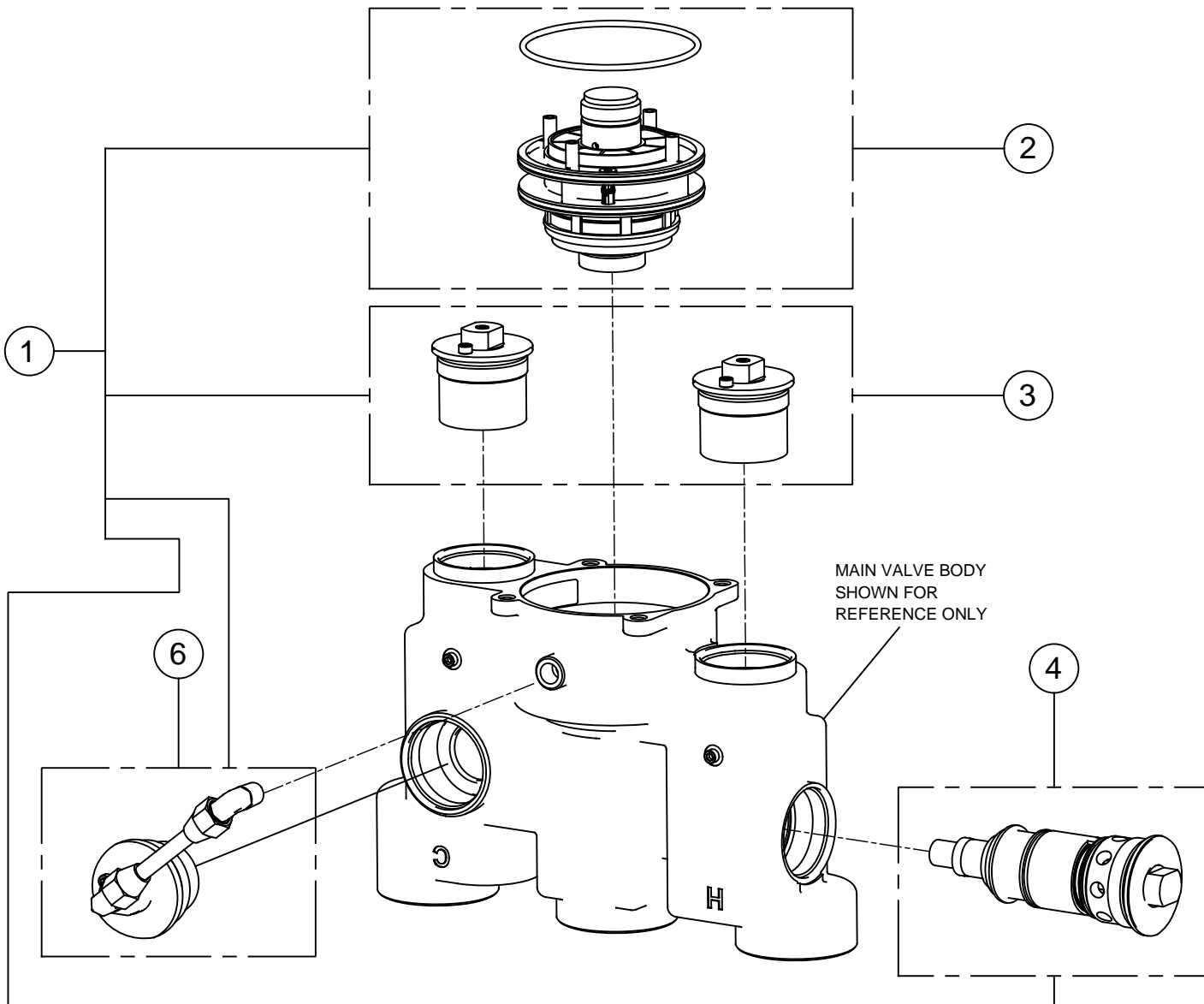



BASIC MAINTENANCE KIT
(NOT SHOWN) INCLUDES ONLY ALL O-RINGS AND THE THERMOSTATS USED IN THE MODEL TWBS.HF VALVE.

PARTS BREAKDOWN

WHEN ORDERING PARTS PLEASE SPECIFY MODEL NUMBER.

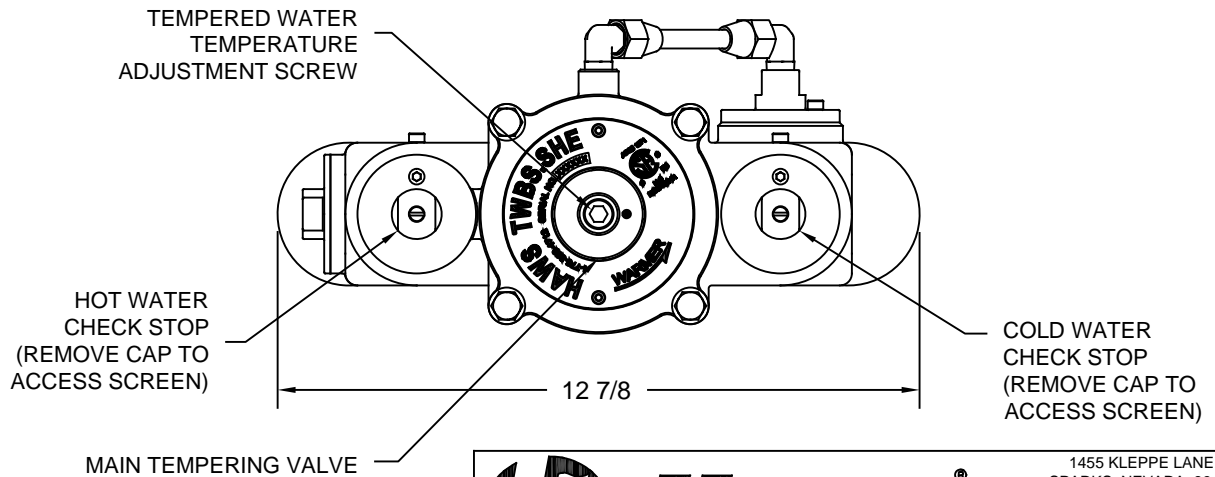
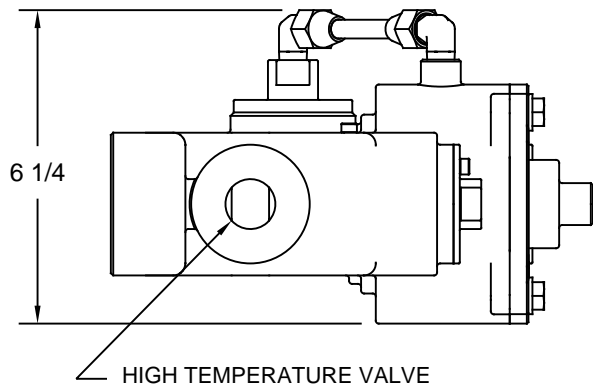
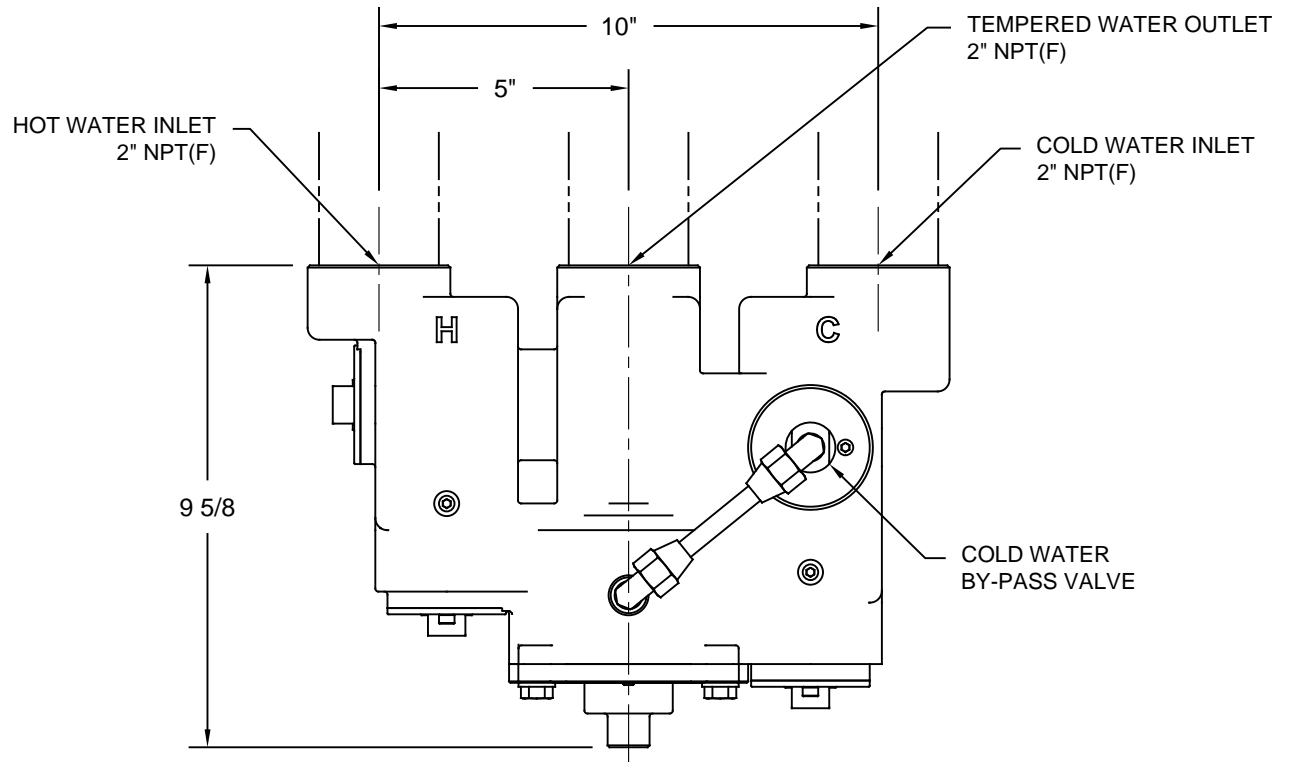
		1455 KLEPPE LANE SPARKS, NEVADA 89431 (775) 359-4712 FAX (775) 359-7424 E-MAIL: HAWS@HAWS.CO.COM WEBSITE: WWW.HAWS.CO.COM	
		ECN NO. 5430 REVISION 08/20/19 DRAWN DP APPROVED DP	REVISED PER DP DATE 08/20/19 DATE 08/21/19
SCALE: 1:1		DRAWING TYPE: PARTS BREAKDOWN	
SIZE: A		SHEET 1 OF 1	



		Haws [®]		1455 KLEPPE LANE SPARKS, NEVADA 89431 (775) 359-4712 FAX (775) 359-7424 E-MAIL: HAWS@HAWSCO.COM WEBSITE: WWW.HAWSCO.COM	
				ECN NO. 4469 DRAWN: VWC APPROVED: DP	REVISED PER: ECN: 5430 DATE: 9/7/2010 DATE: 08/21/19
SCALE: 1:4		DRAWING TYPE: INSTALLATION		SIZE: A SHEET 1 OF 1	