

UNITED Water Products

Model 5400/5450
UL-FM
Vertical Indicator Post

Maintenance and Operation

UL/FM Vertical Indicator Post Configuration



Installation of United Water Products Model 5400/5450 Vertical Indicator Post

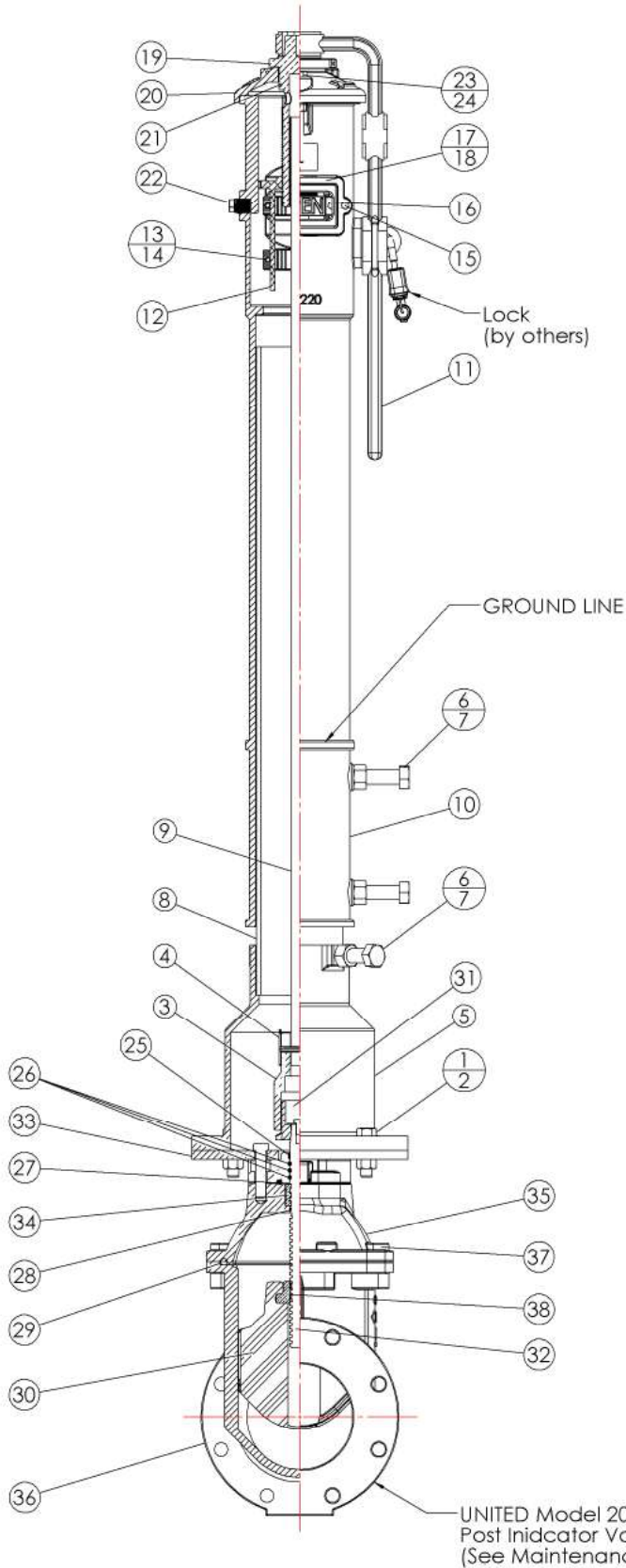

Item No.	Description	Material/Specification
1	Hex Bolt	Carbon Steel ASTM A307B
2	Hex Nut	Carbon Steel ASTM A307B
3	Crane Coupling	Ductile Iron ASTM A536 65-45-12
4	Cotter Pin	AISI 302
5	Base Flange	Cast Iron ASTM A126 Class B
6	Hex Nut	Carbon Steel ASTM A307B
7	Hex Bolt	Carbon Steel ASTM A307B
8	Standpipe	Carbon Steel ASTM A53
9	Stem (1" Square)	AISI 1045
10	Body	Cast Iron ASTM A126 Class B
11	Locking Wrench	Ductile Iron ASTM A536 65-45-12
12	Target Carrier Nut	Bronze ASTM B62 304 Stn. Stl.
13	Hex Bolt	Carbon Steel ASTM A307B
14	Hex Nut	Carbon Steel ASTM A307B
15	Hex Bolt	Carbon Steel ASTM A307B
16	Target	Cast Aluminum
17	Window Glass	Plexiglass
18	Gasket	PTFE
19	Operating Nut	Bronze ASTM B62 304 Stn. Stl.
20	Top Section	Cast Iron ASTM A126 Class B
21	Snap Ring	1066 Stn. Stl.
22	Plug	Malleable Iron
23	Square Nut	Carbon Steel ASTM A307B
24	Hex Bolt	Carbon Steel ASTM A307B
25	Dirt Seal	EPDM
26	O-Ring (Bonnet Cap, Stem)	EPDM
27	O-Ring (Bonnet Cap, Bonnet)	EPDM
28	O-Ring (Stem)	EPDM
29	O-Ring (Bonnet to Body)	EPDM
30	Gate	EPDM Encapsulated DI
31	Operating Nut	Ductile Iron ASTM A536 65-45-12
32	Stem	AISI 420
33	Bonnet Cap/Post Flange	Ductile Iron ASTM A536 65-45-12
34	Split Ring (Stem)	Bronze B62
35	Bonnet	Ductile Iron ASTM A536 65-45-12
36	Body	Ductile Iron ASTM A536 65-45-12
37	Bonnet Allen Bolts	304 Stn. Stl.
38	Gate (Stem) Nut	Bronze B62



Note: Ensure that the Non-rising Stem Gate Valve is in the fully open position before installing the Vertical Indicator Post. DO NOT PROCEED ANY FURTHER UNTIL THIS STEP IS COMPLETED.

1) Disassemble the Indicator Post

Remove the Locking Wrench (11) and loosen the two Hex Bolts (24) and Square Nuts (23). Then remove the Top Section (20), Operating Nut (19), Target Carrier Assembly (12+13+14+16), and the Square Stem (9) and Crane Coupling (3).



Remove the Body (10) from the Standpipe (8) by loosening the upper two Hex Bolts (7) and Hex Nuts (6). Then remove the Standpipe (8) from the Base Flange (5) by loosening the lower two Hex Bolts (7) and Hex Nuts (6).

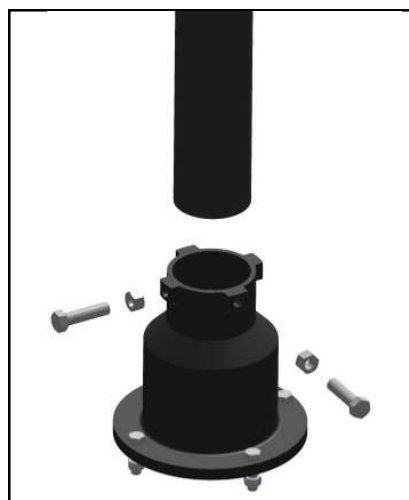
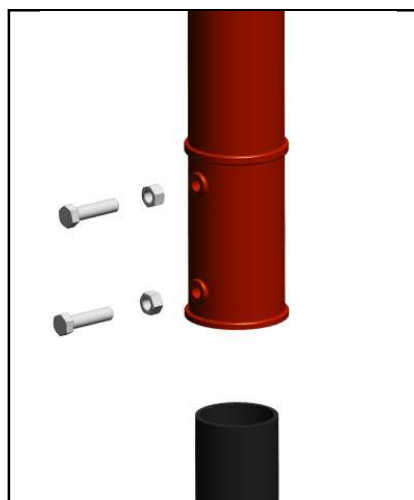

2) Install the Base Flange and Standpipe

Attach the Base Flange (5) to the Post Flange of the Post Indicator Gate Valve using the four Hex Bolts (1) and Hex Nut (2). Then reinsert the Standpipe (8) into the Base Flange (5) and tighten the two Hex Bolts (7) and Hex Nuts (6).

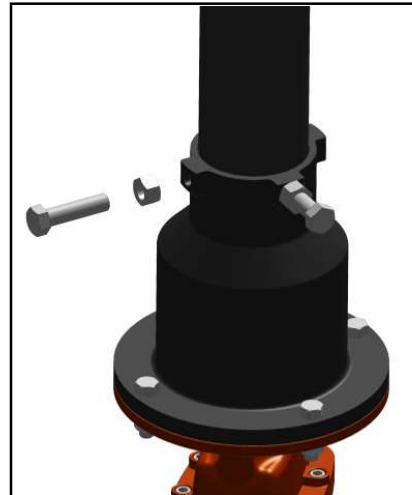
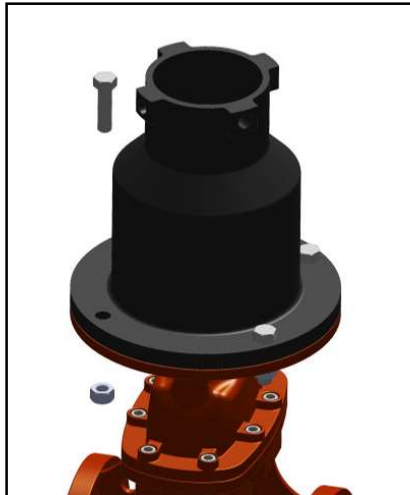

3) Adjust the Ground Line Mark

Lower the Body (10) over the Standpipe (8) until the Ground Line Mark on the Body (10) is the same height as the ground level or finished grade. Tighten the two Hex Bolts (7) and Hex Nut (6).

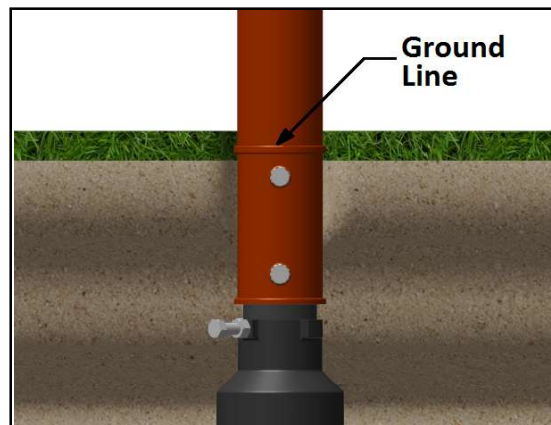

4) Adjust the Square Stem

Lower the Stem (9) into the Body (10)/Standpipe (8) so that the Crane Coupling (3) fits over the operating nut of the Post Indicator Gate Valve. Ensure that the Stem (9) engages the Operating Nut of the Vertical Indicator Post (19) a minimum of 2 inches but no more than 4.5 inches. To check for correct engagement, the end of the Stem (9) should be from 2 to 4.5 inches below the top of the Body (10) where it meets the Top Section (20). If the Stem (9) does not fall within this range, then field-cut and deburr the Stem (9) as necessary.

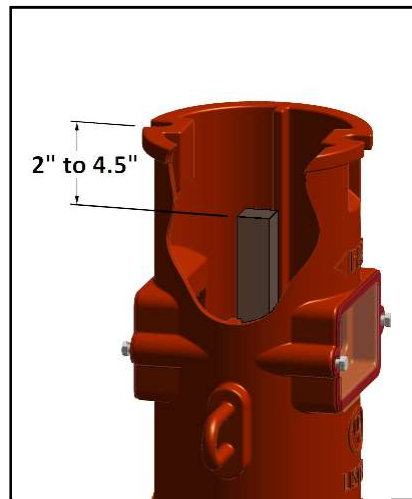
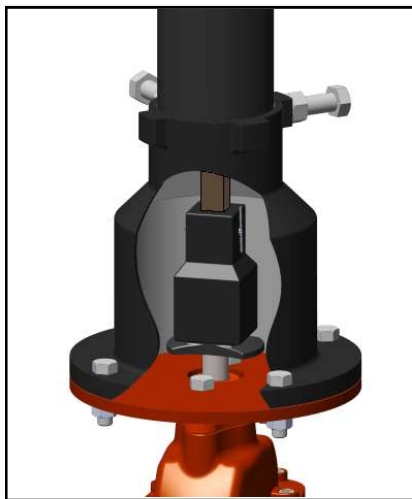

5) Adjust the Targets

The Target Carrier Assembly (12+13+14+16) is adjusted by rotating the Operating Nut (19) with the Target Carrier Assembly held in place. The Open and Shut Targets (16) are adjusted up or down on the Target Carrier Nut (12) by loosening the Target Hex Bolts (13) and Nuts (14), pulling the Target a small distance away from the Target Carrier Nut (12), and sliding the Target up or down as desired. Once the Target is in the correct location, tighten the Hex Bolts (13) and Nuts (14).

If the Non-rising Stem Gate Valve is opened left: Move the two Open Targets (16) to the very top of the Target Carrier Nut (12). Locate the two Shut Targets (16) according to the Non-rising Stem Gate Valve stem size target distance below ("X").

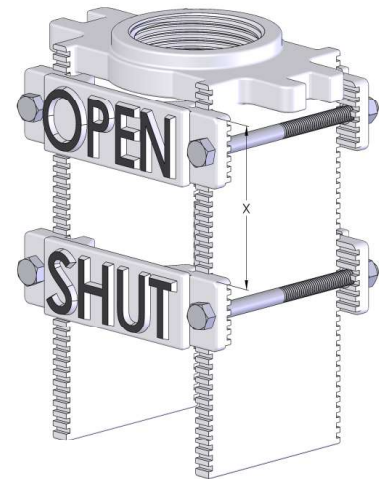
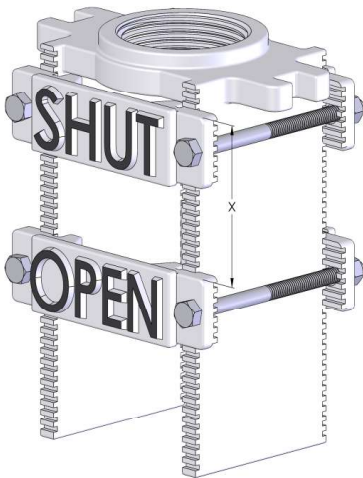

If the Non-rising Stem Gate Valve is opened right: Move the two Shut Targets (16) to the very top of the Target Carrier Nut (12). Locate the two Open Targets (16) according to the Non-rising Stem Gate Valve stem size target distance below ("X").

Approximate* 4"~14" NRS Gate Valve Target Distances (X):

- 4" = 1 1/16" [27 mm]
- 6" = 1 5/8" [41 mm]
- 8" = 2 1/8" [54 mm]
- 10" = 2 5/8" [67 mm]
- 12" = 3 1/8" [79 mm]
- 14" = 5 1/2" [140 mm]

* Field adjust as necessary

6) Final Assembly and Test

Reinsert the Top Section (20), Operating Nut (19), and Target Carrier Assembly (12+13+14+16) into the Body (10) until the bottom of the Top Section (20) rests flush with the top of the Body (10). Check to ensure the Open Target (16) is centered within the Target Window Glass (17). If the Open Target (16) is not centered, then remove, adjust, and reinsert the assembly until it is centered within the Target Window Glass (17). This centering of the Open Target (16) should correspond with the Post Indicator Gate Valve being in the open position. Ensure that the Stem (9) engages with the Operating Nut (19) at least 2 inches but no more than 4.5 inches. Secure the Top Section (20) to the Body (10) by tightening the Hex Bolts (24) and Square Nuts (23). Close the Post Indicator Gate Valve, and make sure that the Shut Target is properly centered in the window of the Body (10), adjusting as necessary.



MAINTENANCE:

Oil the bearing in the Top Section (20) at least once a year by adding several drops of oil in the hole located on the top of the Operating Nut (19).