



SERVICE PARTS LIST

BULLETIN NO.
54-24-5260

SPECIFY CATALOG NO. AND SERIAL NO. WHEN ORDERING PARTS		REVISED BULLETIN	DATE
7/8" (2K) D-HANDLE ROTARY HAMMER			May 2012
CATALOG NO.	5262-20	SERIAL NUMBER	C88A
			WIRING INSTRUCTION See page 4

EXAMPLE:
Component Parts (Small #) Are Included
When Ordering The Assembly (Large #).

● = Component of the 14-46-5262
5262-20 Maintenance Service Kit

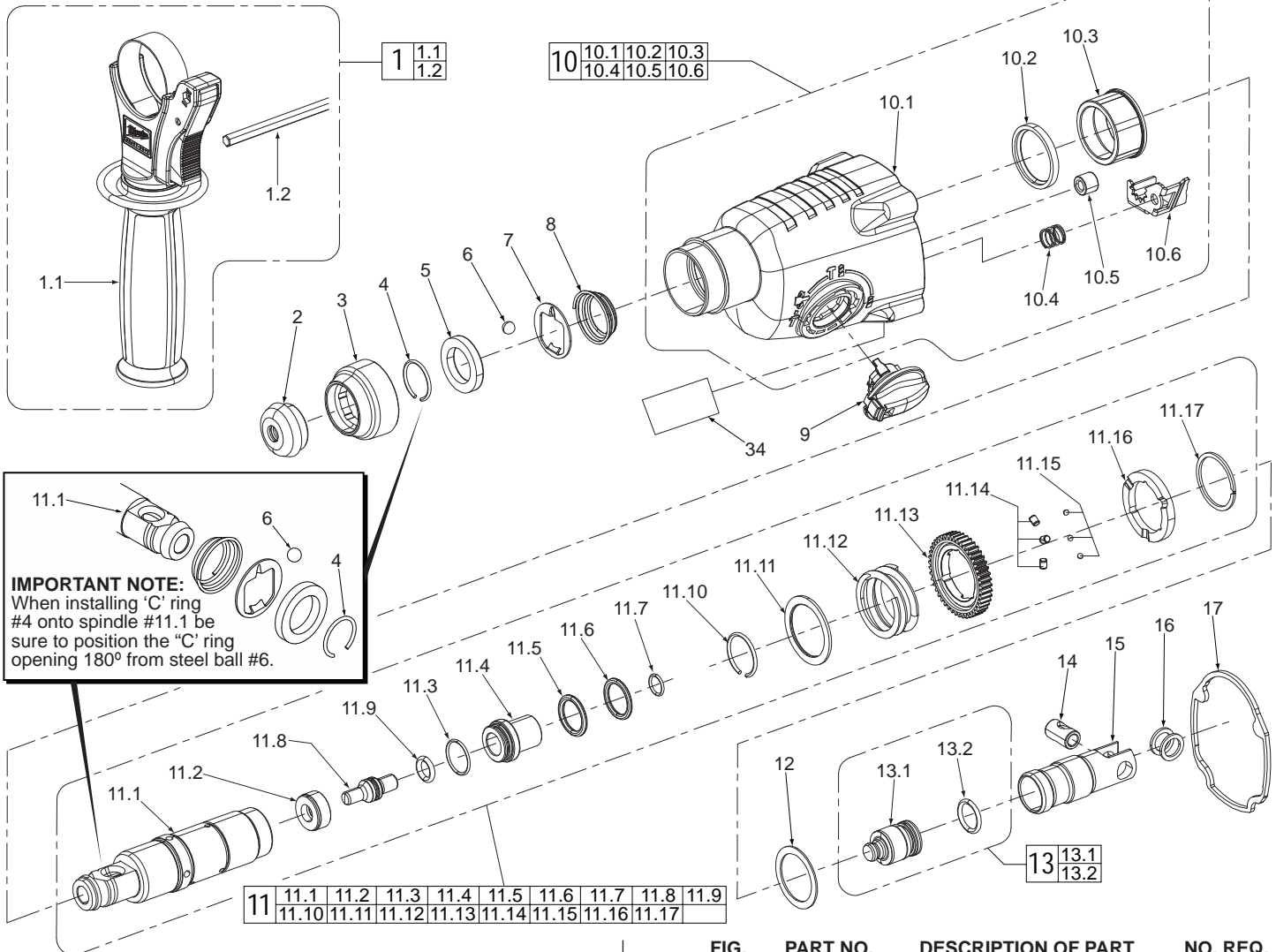

FIG.	PART NO.	DESCRIPTION OF PART	NO. REQ.
1	14-34-5262	Side Handle Assembly	(1)
1.1	31-05-5265	Side Handle	(1)
1.2	44-94-5381	Depth Rod	(1)
2	42-52-5262●	Rubber Cap	(1)
3	42-76-5262●	Collar	(1)
4	44-90-5262●	Spring Ring	(1)
5	44-90-5265	Holding ring	(1)
6	02-02-0275	Steel Ball	(1)
7	42-36-5262	Support Plate	(1)
8	40-50-5262	Pressure Spring	(1)
9	44-10-5262	Shift Lever Assembly	(1)
10	31-40-5262	Gearcase Assembly	(1)
10.1	-----	Gearcase	(1)
10.2	-----	Oil Shield	(1)
10.3	-----	Needle Bearing	(1)
10.4	40-50-5261	Pressure Spring	(1)
10.5	-----	Needle Bearing	(1)
10.6	44-90-1010	Locking Plate	(1)
11	38-50-5275	Spindle Sleeve and Gear Assy.	(1)
11.1	38-50-5262	Spindle Sleeve	(1)
11.2	45-88-5263	Stop Washer	(1)
11.3	34-40-1425●	O-Ring	(1)
11.4	30-37-5262	Sleeve / Striker Guide	(1)

FIG.	PART NO.	DESCRIPTION OF PART	NO. REQ.
11.5	34-40-5261●	O-Ring	(1)
11.6	45-88-5264	Washer	(1)
11.7	34-40-5263●	O-Ring	(1)
11.8	45-08-5262	Anvil	(1)
11.9	34-40-5264●	O-Ring	(1)
11.10	44-90-5263●	Retaining Ring	(1)
11.11	45-88-5266	Washer	(1)
11.12	40-50-5263	Pressure Spring	(1)
11.13	32-75-5262	Spindle Gear	(1)
11.14	44-96-5262	Clutch Roller	(3)
11.15	02-02-1230	Steel Ball	(3)
11.16	42-70-5262	Clutch Disc	(1)
11.17	44-90-0215●	Retaining Ring	(1)
12	45-88-5230	Washer	(1)
13	44-82-5262	Ram Assembly	(1)
13.1	45-56-5262	Ram (Striker)	(1)
13.2	34-40-5265●	O-Ring	(1)
14	44-60-5262	Wrist Pin	(1)
15	44-62-5262	Piston	(1)
16	45-88-5200●	Washer	(2)
17	43-44-5262●	Gasket	(1)
34	12-20-5262	Service Nameplate Kit	(1)

MILWAUKEE ELECTRIC TOOL CORPORATION
13135 W. LISBON RD., BROOKFIELD, WI 53005
Drwg. 4

FIG.	PART NO.	DESCRIPTION OF PART	NO. REQ.
18	28-28-5262	Diaphragm Assembly	(1)
18.1	-----	Bearing	(1)
18.2	-----	Diaphragm	(1)
18.3	-----	Needle Bearing	(1)
18.4	-----	Oil Shield	(1)
18.5	-----	Felt Block	(1)
19	16-07-5262	Armature Assembly	(1)
19.1	-----	Armature	(1)

● = Component of the 14-46-5262
5262-20 Maintenance Service Kit

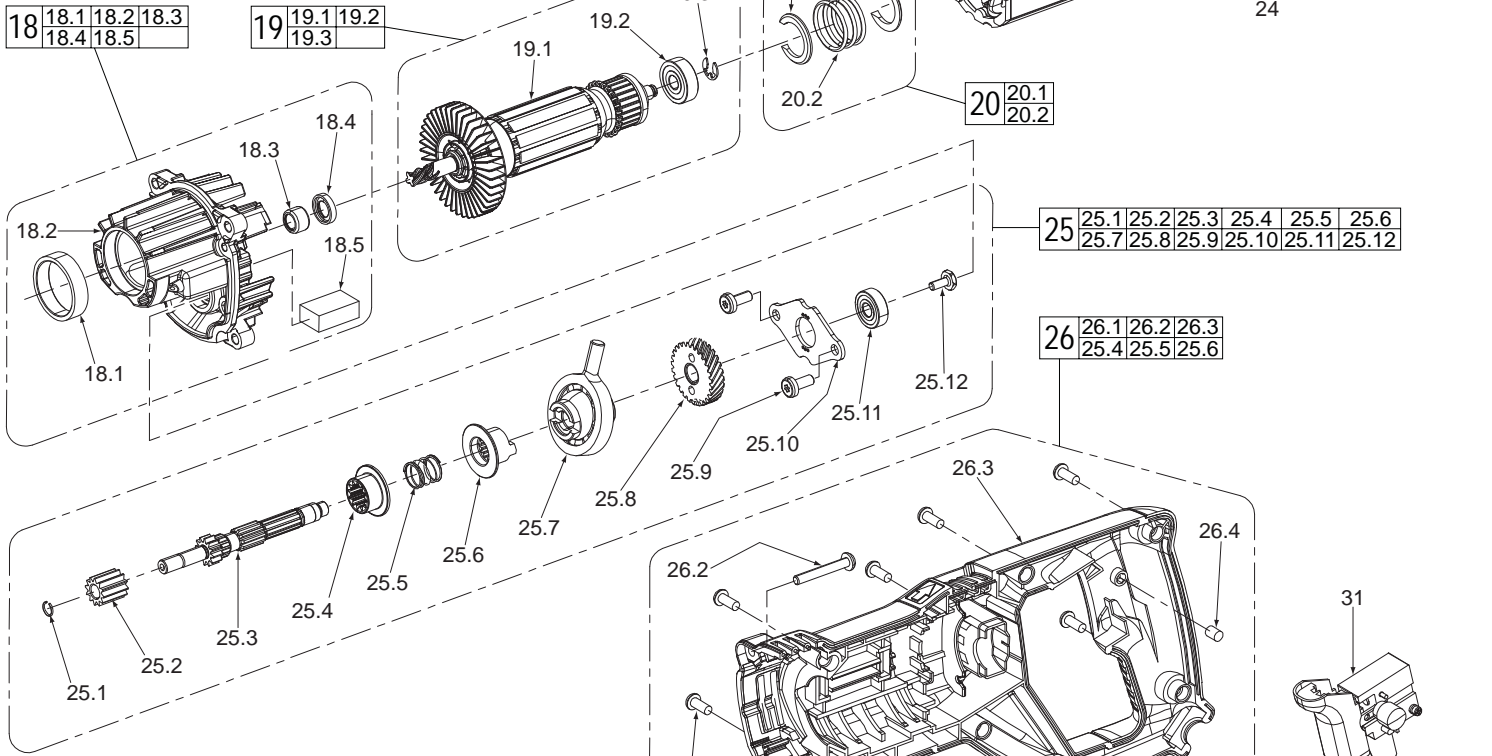
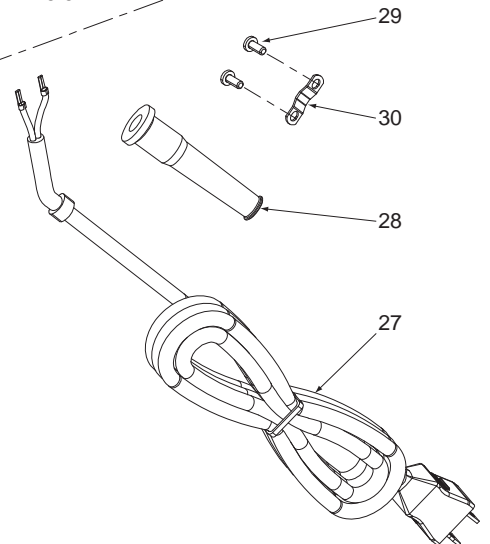
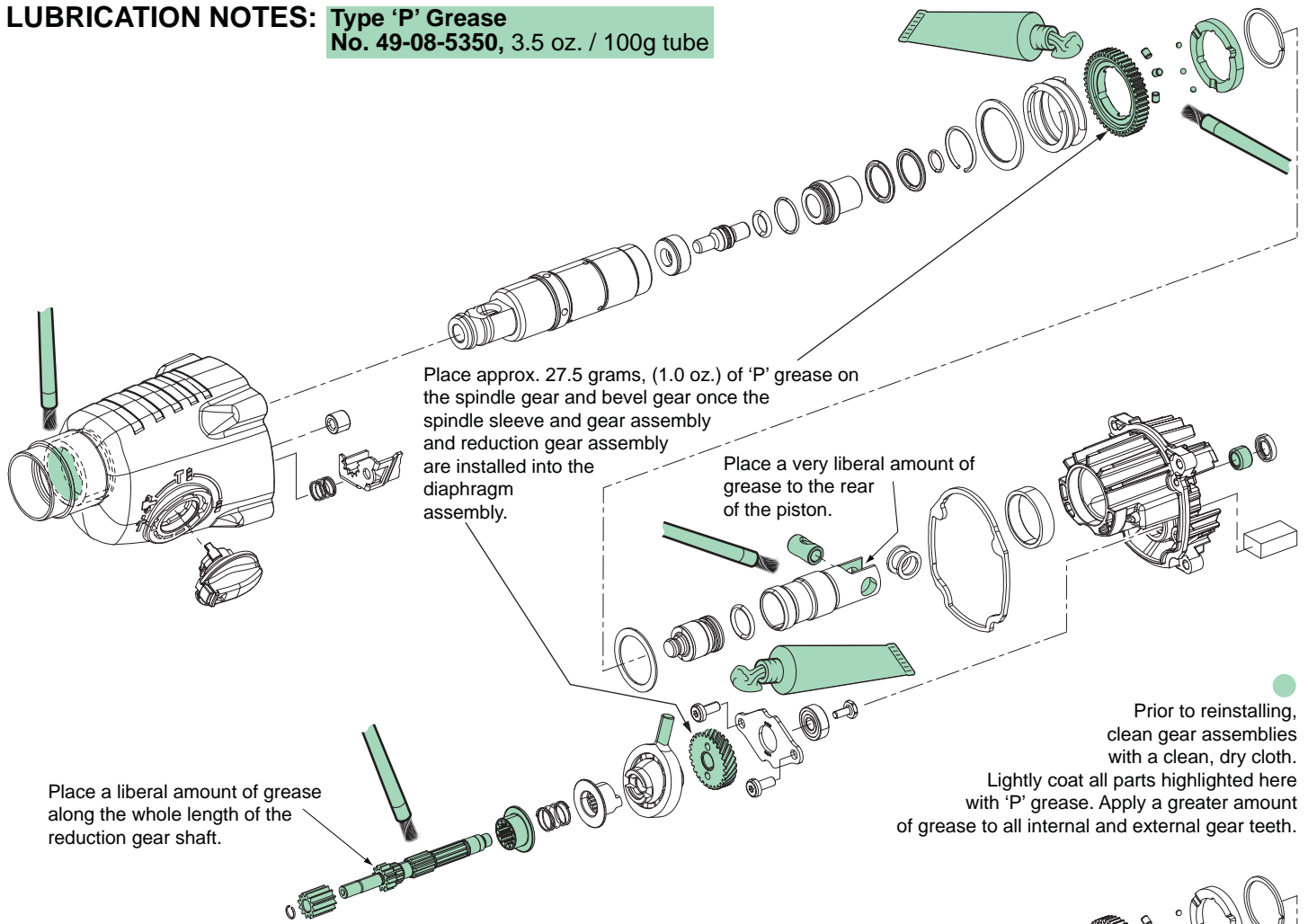

FIG.	PART NO.	DESCRIPTION OF PART	NO. REQ.
19.2	02-04-5262	Ball Bearing	(1)
19.3	44-90-5270	E-Ring	(1)
20	45-88-5205	Washer and O-Ring Assembly	(1)
20.1	45-88-5215	Split Ring Washer	(2)
20.2	34-40-5262	O-Ring	(3)
21	18-07-5262	Service Field	(1)
22	22-18-5262 ●	Carbon Brush Assembly	(1)
23	23-94-5262	Leadwire Assembly - White	(1)
24	23-94-5265	Leadwire Assembly - Black	(1)
25	36-66-5262	Reduction Gear Assembly	(1)
25.1	44-90-5264 ●	C- Ring	(1)
25.2	32-60-5262	Pinion Gear	(1)
25.3	36-66-5261	Reduction Gear Shaft	(1)
25.4	32-60-5261	Internal Gear Wheel	(1)
25.5	40-50-5260	Pressure Spring	(1)
25.6	45-22-5262	Clutch Sleeve	(1)
25.7	36-92-5262	Wobble Drive	(1)
25.8	32-05-5262	Bevel Gear	(1)
25.9	05-78-5262 ●	M5 x 0.8 T-25 Screw	(2)
25.10	42-36-5261	Bearing Cover	(1)
25.11	02-04-5385	Ball Bearing	(1)
25.12	05-74-5262 ●	M4 x 0.7 T-15 Screw	(1)
26	31-44-5262	Housing Assembly	(1)
26.1	05-81-5262	M4 x 1.4 Pan Hd. Plast. T-15 Scr.	(8)
26.2	05-81-5265 ●	M4.5 x 1.5 Pan Hd. T-20 Screw	(4)
26.3	-----	Housing - Right	(1)
26.4	44-60-5265	Pin	(1)
26.5	44-60-5270	Pin	(2)
26.6	-----	Housing - Left	(1)
27	22-64-5262	Power Cord	(1)
28	44-76-0210	Cord Protector	(1)
29	05-78-5313	M4 x 1.3 T-15 Screw	(2)
30	42-68-0601	Cord Clamp	(1)
31	23-66-5262	Switch	(1)
33	42-55-5262	Molded Carrying Case	(1)



LUBRICATION NOTES: Type 'P' Grease
No. 49-08-5350, 3.5 oz. / 100g tube



Place approx. 27.5 grams, (1.0 oz.) of 'P' grease on the spindle gear and bevel gear once the spindle sleeve and gear assembly and reduction gear assembly are installed into the diaphragm assembly.

Place a very liberal amount of grease to the rear of the piston.

Place a liberal amount of grease along the whole length of the reduction gear shaft.

Prior to reinstalling, clean gear assemblies with a clean, dry cloth. Lightly coat all parts highlighted here with 'P' grease. Apply a greater amount of grease to all internal and external gear teeth.

LUBRICATION NOTES: Type 'Q2' Grease
No. 49-08-5345, 1.5 oz. / 45g tube

Lightly coat all parts highlighted here with 'Q2' grease unless directed otherwise.

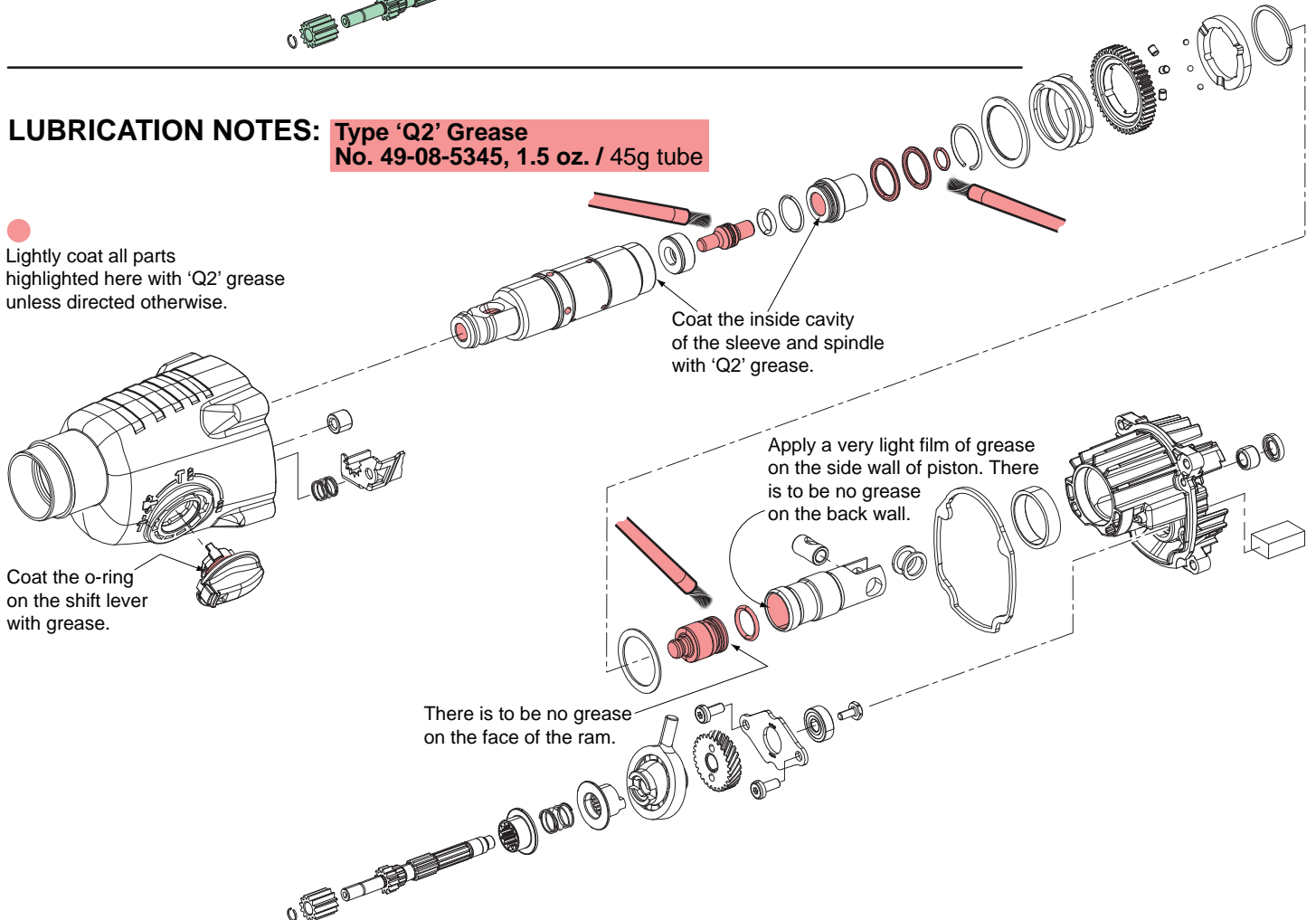

Coat the o-ring on the shift lever with grease.

Coat the inside cavity of the sleeve and spindle with 'Q2' grease.

Apply a very light film of grease on the side wall of piston. There is to be no grease on the back wall.

There is to be no grease on the face of the ram.

●14-46-5262

Rotary Hammer Service Kit

2	42-52-5262	Dust Cap	(1)
3	42-76-5262	Locking Sleeve	(1)
4	44-90-5262	C-Ring	(1)
11.3	34-40-1425	O-Ring	(1)
11.5	34-40-5261	O-Ring	(1)
11.7	34-40-5263	O-Ring	(1)
11.9	34-40-5264	O-Ring	(1)
11.10	44-90-5263	C-Ring	(1)
11.17	44-90-0215	Retaining Ring	(1)
13.2	34-40-5265	O-Ring	(1)
16	45-88-5200	Washer	(2)
17	43-44-5262	Gasket	(1)
22	22-18-5262	Carbon Brush Assy.	(1)
25.1	44-90-5264	C-Ring	(1)
25.9	05-78-5262	M5.0 x 0.8 Screw	(2)
25.12	05-74-5262	M4.0 x 0.7 Screw	(1)
26.2	05-81-5265	Taptite Screw	(4)
	49-08-5350	'P' Grease 100g tube	(1)
	49-08-5345	'Q2' Grease 45g tube	(1)

SCREW TORQUE CHART

Item	Part Number	Where Used	Seat Torque (Kgf/cm)	Seat Torque (In/Lbs)
25.9	-----	Bearing Cover Screw	80-90	69-78
25.12	-----	Reduction Gear Bearing Screw	30-35	26-30
26.1	05-81-5262	Handle Screw	16-21	14-18
26.2	05-81-5265	Handle/Gearcase Screw	30-35	26-30
29	05-78-5313	Cord Clamp Screw	13-15	11-13
	-----	Switch Screw	4-6	3-5

WIRING INSTRUCTIONS

NOTE: As an aid to reassembly, take note of the wire routings and position of the wires in the wire guides and traps prior to dismantling the tool.

Watch for pinched wires when placing the handle cover back over the housing assembly.

Terminals on wire #3 and #4 are to be positioned onto field tabs with the barrels facing outward

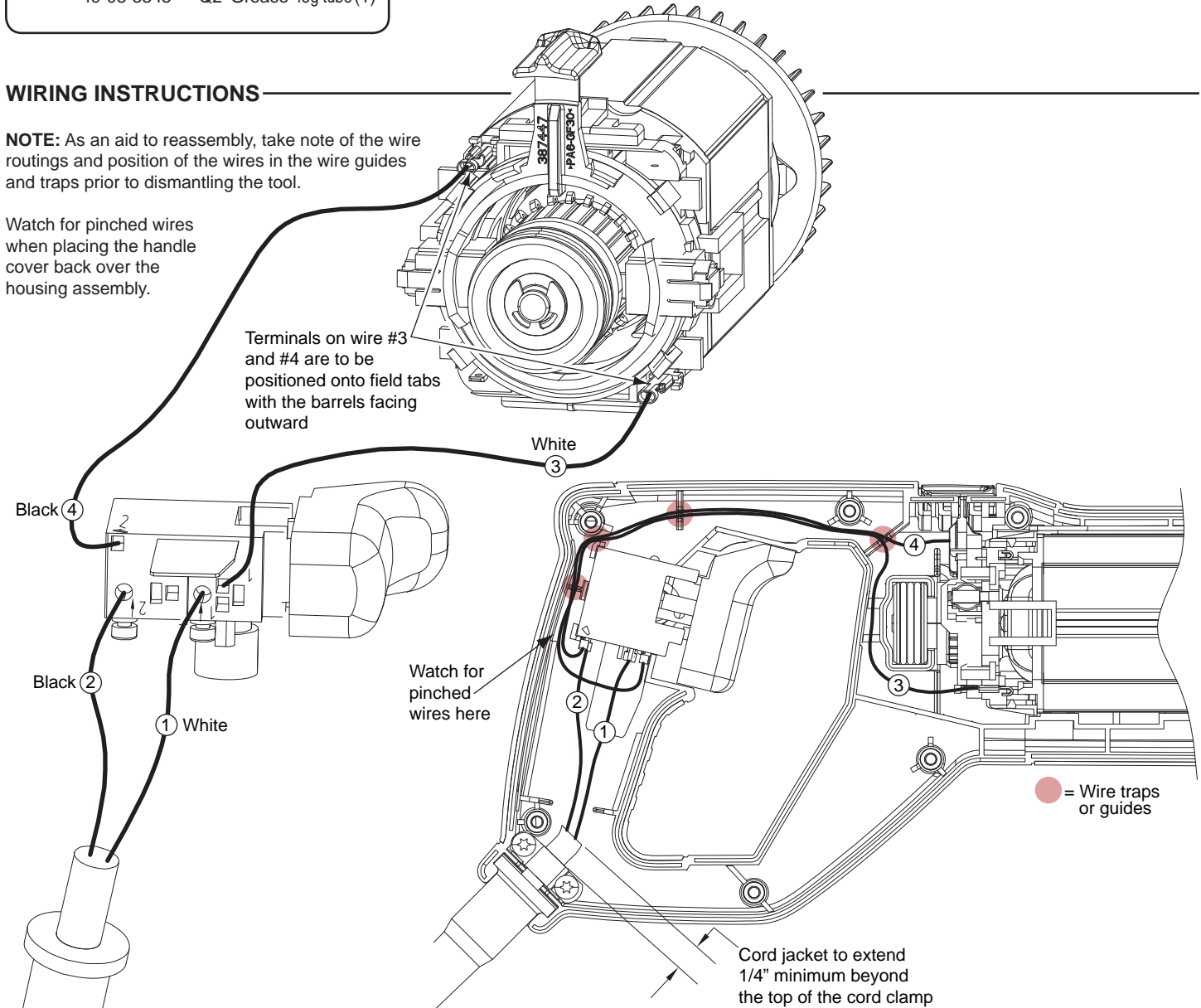

WIRING SPECIFICATIONS

Wire No.	Wire Color	Origin or Gauge	Length	Terminals, Connectors and 1 or 2 End Wire Preparation
1	White	-----	-----	Component of cord set. Connect to '1↓' on switch.
2	Black	-----	-----	Component of cord set. Connect to '2↓' on switch.
3	White	23-94-5262	-----	Connect to '1' on switch and the bottom right of field.
4	Black	23-94-5265	-----	Connect to '2' on switch and the top left of field.