



BAYLPSS220C Stainless Steel Propane Conversion Kit for 3 Stage Furnaces *UH3/*DH3 and Modulating Furnaces *UHM/*DHM

*First letter may be "A" or "T"

ALL phases of this installation must comply with NATIONAL, STATE AND LOCAL CODES

IMPORTANT—This Document is customer property and is to remain with this unit. Please return to service information pack upon completion of work.

NOTE: The Modulating Furnace and 3 Stage Furnace Installer's Guides and Service Facts may contain information regarding LP conversion, BAYLP**220A information, orifice sizing, and gas manifold pressures. Please disregard that information and use this Installer's Guide for those instructions.

⚠ WARNING

This conversion kit shall be installed by a qualified service agency in accordance with manufacturer's instructions and all applicable codes and requirements of the authority having jurisdiction. If the information in these instructions is not followed exactly, a fire, explosion or production of carbon monoxide may result causing property damage, personal injury or loss of life. The qualified service agency is responsible for the proper installation of the kit. The installation is not proper and complete until the operation of the converted furnace is checked as specified in the manufacturer's instructions supplied with the kit.

⚠ WARNING

EXPLOSION HAZARD

Propane gas is heavier than air and may collect in any low areas or confined spaces. In addition, odorant fade may make the gas undetectable except with a warning device. If the gas furnace is installed in a basement, an excavated area, or confined space, it is strongly recommended to contact a gas supplier to install a gas detecting warning device in case of a leak. Failure to follow this warning could result in serious personal injury, property damage, or death. The manufacturer of your furnace does not test any detectors and makes no representations regarding any brand of detector.

⚠ CAUTION

The *UH3, *DH3, *UHM, and *DHM furnaces are not allowed to be vented with anything smaller than 3" pipe. See Vent Length Table on back page.

PROPANE ORIFICE		
MODELS IN 1000's BTUH	QUANTITY OF ORIFICE	ORIFICE SIZE
60	3	56
80	4	56
100	5	56
120	6	56

Table 2

Each Kit Contains:		Part Number
1	Propane Label Conversion Label Conversion Responsibility Label	B342003P08
1	Installer's Guide	18-CH38D1-7A-EN
6	Orifice Main Burner #56 - Black	B138253P33 (ORF01428)
2	2" x 3" Coupling - PVC	A341772P01 (CPL00938)
1	Propane Gas Valve	D343532P04 (VAL10382)
6	Stainless Steel Burner	C341795P03 (BRN01077)
1	Wire Harness Jumper	D344460P01

A. GENERAL

These instructions describe converting gas furnaces from natural gas to Propane gas.

Conversion from natural gas to Propane gas is a critical procedure, therefore, these INSTRUCTIONS MUST BE FOLLOWED CLOSELY.

B. INSPECTION

1. Unpack all components of the Propane conversion kit.
2. Check carefully for any shipping damage. If any damage is found, this must be reported immediately and a claim made against the transportation company.
3. Check to be sure all components are in the package. Any missing components should be reported to your supplier at once and replaced with authorized components only.

⚠ WARNING

Replace and/or tighten all plugs removed or loosened when adjusting gas pressure. Leak check the fittings before placing the furnace into regular service.

Failure to follow this warning could result in fire, explosion or property damage.

Installer's Guide

C. CONVERSION INSTRUCTIONS

*UH3, *DH3, *UHM, AND *DHM MODELS ONLY

⚠ CAUTION

The gas supply must be shut off and the electrical power disconnected before proceeding with the conversion.

NOTE: Before the conversion, these models require the removal of the burner box front cover.

1. Before beginning, make note of the pressure switch tubing that is connected to the gas valve. Label if necessary. Remove tubing from gas valve.
2. Remove the low voltage wiring from the gas valve.
3. Remove the burner box cover and manifold assembly (with gas valve attached) by removing the 4 5/16" hex screws.
4. Remove the top burner bracket. See Figure 1.
5. Remove the existing burners and install the new stainless steel burners.
6. Reinstall the top burner bracket removed in Step 4.
7. Remove all main burner natural gas orifices and discard.
8. Install the #56 size orifices to the same depth as the orifices supplied with the equipment.
9. Using a back-up wrench, remove the existing gas valve.
10. Apply thread compound or teflon tape onto the manifold.
11. Using a back-up wrench, install the new LP gas valve on the manifold so that the bottom of the valve is in the vertical position. (Install the new LP gas valve on the manifold so that the top of the valve will be facing the front of the furnace)
12. Reinstall the manifold assembly and burner box cover removed in step 3. See Figure 2
13. Reconnect low voltage wiring removed in step 2. Use included wire harness jumper if factory wire harness is too short.
14. Reconnect tubing removed in step 1 and connect to gas supply. See Figure 3 for proper connections.
15. Complete the Conversion Responsibility portion of the label and apply to the front of the furnace. See Figure 4.
16. Apply the conversion label on the furnace below the nameplate.
17. Apply the "Propane Kit" label onto the gas valve.

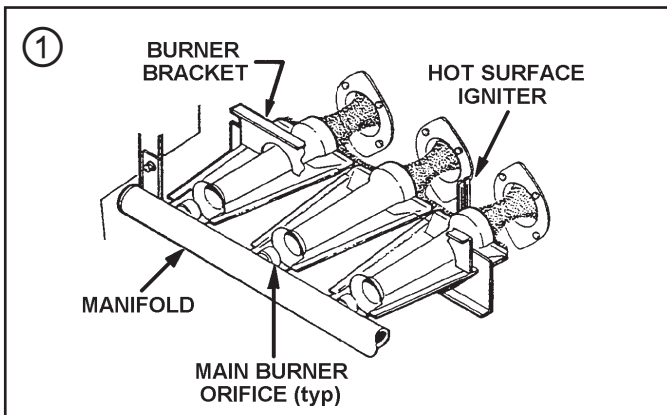

⚠ CAUTION

When removing extreme right burner, use caution NOT to break the ignitor assembly.

NOTE: Use back-up wrench when removing gas valve.

⚠ CAUTION

Check the ignitor alignment when replacing extreme right burner, use caution NOT to break the ignitor assembly.

18. Turn "ON" the gas supply and electrical power. Check for leaks with a soapy solution. DO NOT CHECK WITH AN OPEN FLAME.
19. For complete detailed sequence of operation, refer to the Installer's Guide or the Service Facts supplied with the furnace.
20. Set the Comfort Control to call for operation.
21. Check the complete operation of the unit. Check the manifold gas pressure as specified in the furnace Installer's guide. Only for 3 stage and Modulating furnaces using LP gas, LP gas manifold pressure on high fire is 10.0 inches W.C. See Table 3.

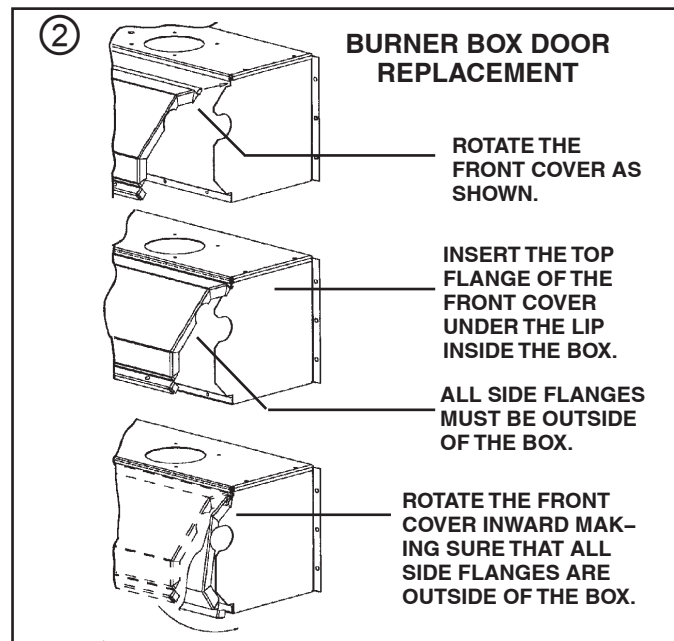

Installer's Guide

Table 3

Furnace Input rate (KBTU/hr)	FINAL MANIFOLD PRESSURE SETTINGS (inches w.c.)		
	1st Stage 40% (low heat)	2nd Stage 65% (medium heat)	3rd Stage 100% (high heat)
60	2.1 ± 0.5	Not Adjustable	10.0 ± 0.5
80	2.1 ± 0.5	Not Adjustable	10.0 ± 0.5
100	2.1 ± 0.5	Not Adjustable	10.0 ± 0.5
Downflow 120	2.1 ± 0.5	Not Adjustable	10.0 ± 0.5
Upflow 120	2.9 ± 0.5	Not Adjustable	10.0 ± 0.5

For upflow 120 KBTU/hr model, 1st stage is 45%

AIRFLOW ADJUSTMENT

NOTE:

LP conversion requires a minimum 3" PVC combustion air intake and vent piping complying with the USA and Canada for 3 Stage and Modulating Furnaces.

Check inlet and outlet air temperatures to make sure they are within the ranges specified on the furnace rating nameplate. If the airflow needs to be increased or decreased, see the User Interface Menu for information on changing the speed of the blower motor.

④

Three-part Conversion Label

This furnace was converted on _____
(day-month-year)
to PROPANE gas with
Kit No. BAYLPSS220C
by _____

(Name & Address of organization making this conversion), which accepts the responsibility that this conversion has been properly made.

Ce générateur d'air chaud a été converti le _____

(jour-mois-année)
pour fonctionner au gaz
PROPANE

à l'aide de l'ensemble
n° BAYLPSS220C
par _____

(Nom et adresse de l'organisme qui a effectué la conversion), qui accepte l'entière responsabilité de la conversion.

THIS APPLIANCE HAS BEEN FIELD CONVERTED FROM NATURAL TO PROPANE GAS AT THE IDENTICAL INPUT RATING OF ORIGINAL EQUIPMENT WITH PARTS AND INSTRUCTIONS SUPPLIED BY THE APPLIANCE MANUFACTURER.

PROPANE KIT
BAY0000000000

Apply label to the front of the furnace

Apply label below the nameplate

Apply label onto the gas valve

③

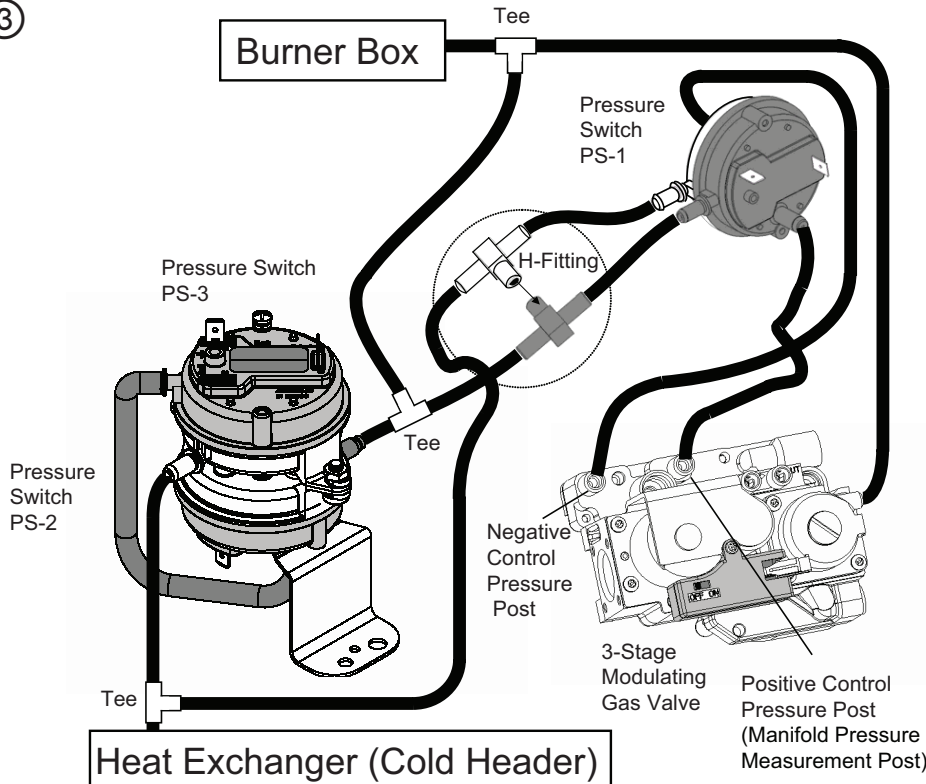

Installer's Guide

Table 4

VENT LENGTH TABLE						
ALTITUDE	MAXIMUM TOTAL EQUIVALENT LENGTH IN FEET FOR VENT AND INLET AIR (SEE NOTES)					
0-7000 Feet	2 INCH PIPE		2.5 INCH PIPE		3 or 4 INCH PIPE	
	NATURAL GAS	PROPANE	NATURAL GAS	PROPANE	NATURAL GAS	PROPANE
UH/DH3B060ACV3V UH/DHMB060ACV3V	200	Not Allowed	200	Not Allowed	200	150
UH/DH3B080ACV3V UH/DHMB080ACV3V	50	Not Allowed	120	Not Allowed	200	150
UH/DH3C100ACV4V UH/DHMC100ACV4V	Not Allowed	Not Allowed	60	Not Allowed	200	150
UH3/UHMD120ACV5V DH3/DHMD120ACV5V	Not Allowed	Not Allowed	Not Allowed	Not Allowed	200	150
	Not Allowed	Not Allowed	Not Allowed	Not Allowed	200	100
7000-9500 Feet	2 INCH PIPE		2.5 INCH PIPE		3 or 4 INCH PIPE	
	NATURAL GAS	PROPANE	NATURAL GAS	PROPANE	NATURAL GAS	PROPANE
UH/DH3B060ACV3V UH/DHMB060ACV3V	100	Not Allowed	100	Not Allowed	100	100
UH/DH3B080ACV3V UH/DHMB080ACV3V	25	Not Allowed	60	Not Allowed	100	100
UH/DH3C100ACV4V UH/DHMC100ACV4V	Not Allowed	Not Allowed	30	Not Allowed	100	100
UH3/UHMD120ACV5V DH3/DHMD120ACV5V	Not Allowed	Not Allowed	Not Allowed	Not Allowed	100	100
	Not Allowed	Not Allowed	Not Allowed	Not Allowed	100	50
9500-12000 Feet	2 INCH PIPE		2.5 INCH PIPE		3 or 4 INCH PIPE	
	NATURAL GAS	PROPANE	NATURAL GAS	PROPANE	NATURAL GAS	PROPANE
UH/DH3B060ACV3V UH/DHMB060ACV3V	50	Not Allowed	50	Not Allowed	50	38
UH/DH3B080ACV3V UH/DHMB080ACV3V	Not Allowed	Not Allowed	30	Not Allowed	50	38
UH/DH3C100ACV4V UH/DHMC100ACV4V	Not Allowed	Not Allowed	Not Allowed	Not Allowed	50	38
UH3/UHMD120ACV5V DH3/DHMD120ACV5V	Not Allowed	Not Allowed	Not Allowed	Not Allowed	50	38
	Not Allowed	Not Allowed	Not Allowed	Not Allowed	50	25

Notes: * - First letter may be "A" or "T", ** - Last two digits may be "A" thru "Z"

1. Minimum vent length for all models: 3' horizontal or 3' vertical
2. DO NOT MIX PIPE DIAMETERS IN THE SAME LENGTH OF PIPE OUTSIDE THE FURNACE CABINET, (Except adapters at the top of the furnace). If different inlet and vent pipe sizes are used, the vent pipe must adhere to the maximum length limit shown in the table above (See note 6 below for exception). The inlet pipe can be of a larger diameter, but never smaller than the vent pipe.
3. MAXIMUM PIPE LENGTHS MUST NOT BE EXCEEDED! THE LENGTH SHOWN IS NOT A COMBINED TOTAL, IT IS THE MAXIMUM LENGTH OF EACH (Vent or Inlet air pipes).
4. One SHORT radius 90° elbow is equivalent to 10' of 3" pipe and one LONG radius elbow is equivalent to 6' of 3" pipe. One 90° elbow is equivalent to 7½' of 2½" pipe or 5' of 2" pipe. Two 45° elbows equal one 90° elbow.
5. The termination tee or bend must be included in the total number of elbows. If the BAYAIR30AVENTA termination kit is used, the equivalent length of pipe is 5 feet. BAYVENT200B equivalent length is 0 feet.
6. Pipe adapters are field supplied. Downflow models, UY/UH2/UH3/UHM 100, and UY/UH2/UH3/UHM 120 models include the 2" x 3" adapter.
7. For Canadian applications ONLY, IPEX 196006 may be used for horizontal and vertical terminations. IPEX 081216, IPEX 081218, and IPEX 081219 may only be used for horizontal vent terminations. Equivalent lengths are IPEX 196009 = 5 feet, IPEX 081216 = 11 feet, IPEX 081218 = 16 feet, and IPEX 081219 = 21 feet

About Trane and American Standard Heating and Air Conditioning

Trane and American Standard create comfortable, energy efficient indoor environments for residential applications. For more information, please visit www.trane.com or www.americanstandardair.com

The manufacturer has a policy of continuous data improvement and it reserves the right to change design and specifications without notice. We are committed to using environmentally conscious print practices.